



**ISAP TC on
Constitutive Modelling
of Asphaltic Materials**





ISAP TC on Constitutive Modelling of Asphaltic Materials



The TC **co-ordinates activities** in constitutive modelling of asphalt from around the world within the framework of the **International Society for Asphalt Pavements** ([ISAP](#))

THE SCOPE OF THE TC:

The **encouragement of research** into constitutive modelling of asphalt and the **dissemination of knowledge** into the sector.

Technical Committee on Constitutive Modelling of Asphaltic Materials



TC BOARD

CHAIRMAN
Tom Scarpas

SECRETARY
Niki Kringos



WG01: on Foam Asphalt

Coordinator: A. Loizos

WG02: on Moisture Damage in Asphaltic Mixes

Coordinator: E. Masad

WG03: on Shared Testing for Constitutive Modelling

Coordinator: A. Collop

WG04: on Reinforcement of Asphalt

Coordinator: I. Al-Qadi

WG05: on Re-use of Construction Materials

Coordinator: M. Partl

WG06: on Chemo-Mechanics of Bituminous Materials

Coordinator: J. Youtcheff

WG07: on Bitumen and Mastics

Coordinator: H. Bahia

Technical Committee on Constitutive Modelling of Asphaltic Materials



Technical Committee on Constitutive Modelling of Asphaltic Materials

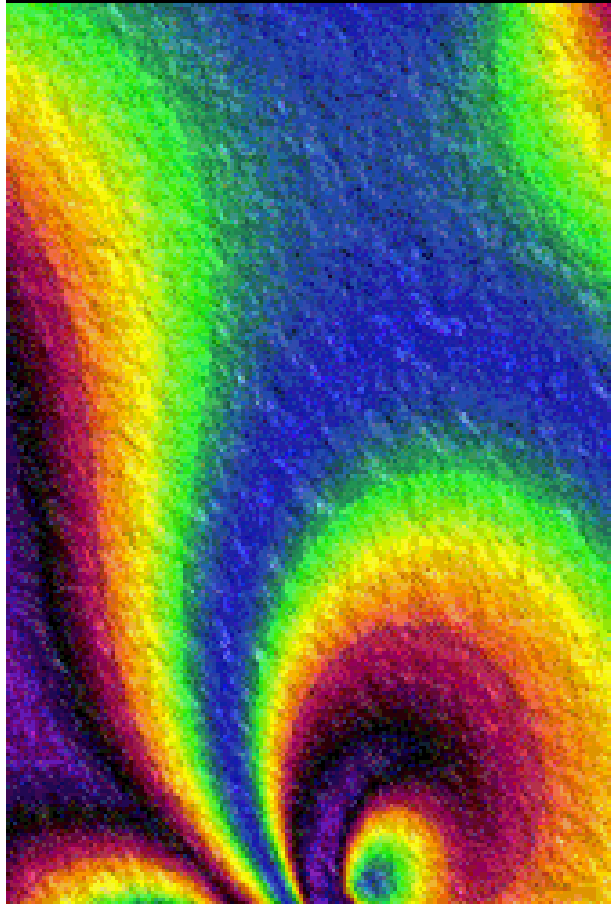

*International Course Series on Advanced
Constitutive Modeling of Pavement and Soil
Engineering Materials*

**An Intensive Course on:
ADVANCED CONSTITUTIVE
MODELING OF ASPHALTIC
MATERIALS**

5-8 January 2005, Maryland, USA

[MORE INFO](#)

Technical Committee on Constitutive Modelling of Asphaltic Materials



*International Course Series on Advanced
Constitutive Modeling of Pavement and Soil
Engineering Materials*

Applied Tensor Analysis for
Constitutive Modeling

Delft, June 2004

[MORE INFO](#)

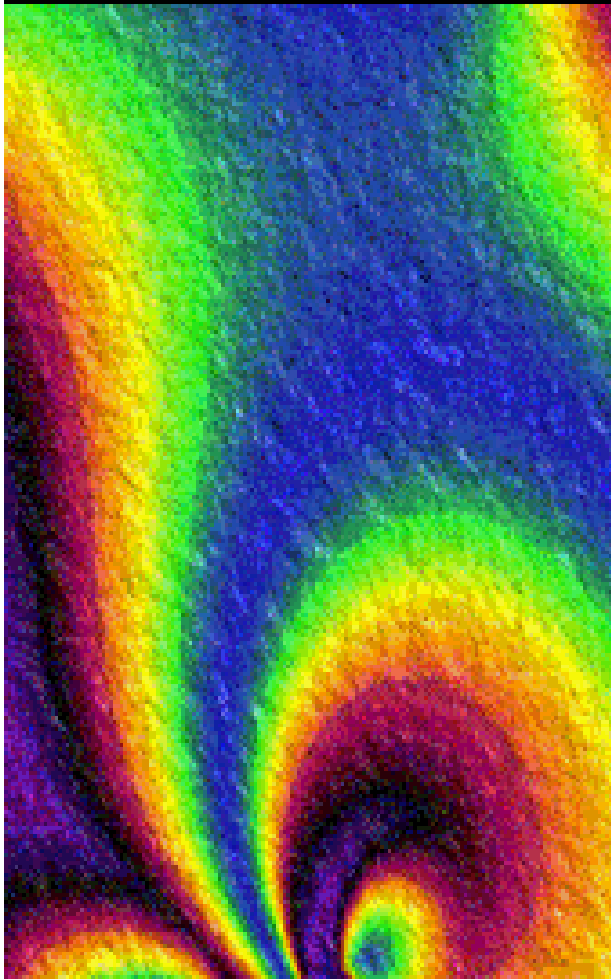

Technical Committee on Constitutive Modelling of Asphaltic Materials



International Course Series on Advanced
Constitutive Modeling of Pavement and Soil

International Course Series on Advanced
Constitutive Modeling of Pavement and Soil
Engineering Materials

**An Intensive Course on:
ADVANCED CONSTITUTIVE
MODELING OF ASPHALTIC
MATERIALS**

5-8 January 2005, Maryland, USA

[MORE INFO](#)

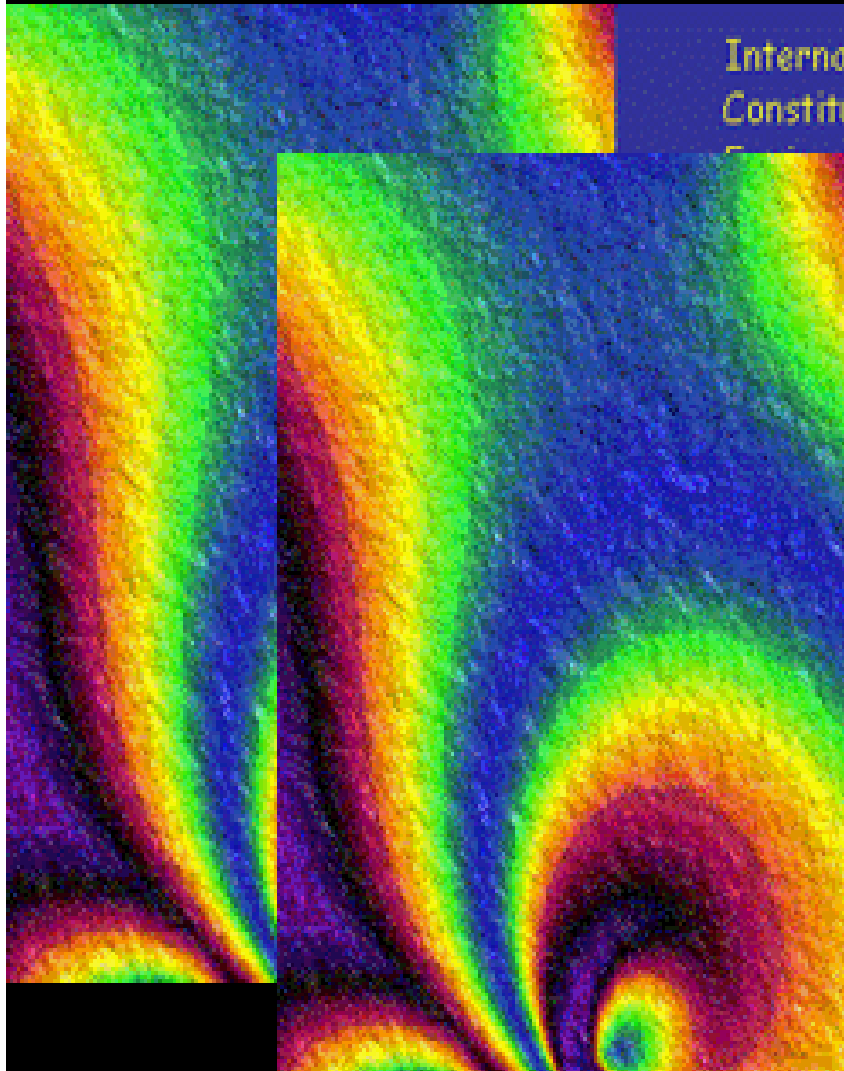

Technical Committee on Constitutive Modelling of Asphaltic Materials



International Course Series on Advanced
Constitutive Modeling of Pavement and Soil

International Course Series on Advanced
Constitutive Modeling of Pavement and Soil
Engineering Materials

Date and location

The course is under the auspices of the ISAP TC Constitutive Modeling of Asphaltic Materials and shall be held from 21-25 September 2009 in College Station, Texas at the Campus of the Texas A&M University, USA. Details about the location and nearby hotel arrangements are available at www.insapconmod.nl.

Language

All lectures and course handout materials are in English.

Registration

The course fee is US\$ 900. A special reduced fee of US\$ 700 applies for graduate students.

To register, please visit the course link at www.insapconmod.nl or go directly to <https://tti.tamu.edu/conferences/amc09/registration.htm>

After registration, participants will receive a letter of confirmation, travel and accommodation suggestions. Registration is final after the course fee has been received. The total number of participants is limited, registration will be accepted according to availability.

The organizers reserve the right to make necessary amendments to the program. For additional information and course news please refer to: www.insapconmod.nl

ISAP TC Constitutive Modeling of Asphaltic Materials

International Course Series on
Advanced Constitutive Modeling of
Pavement and Soil Engineering Materials

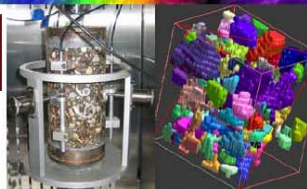

TEXAS 21-25 Sept. 2009

AN INTENSIVE COURSE ON:
ADVANCED CONSTITUTIVE MODELING
AND CHARACTERIZATION OF
ASPHALTIC MATERIALS

Technical Committee on Constitutive Modelling of Asphaltic Materials



International Workshop on

Moisture Induced Damage of Asphaltic Mixes

Characterization, Visualization and Simulation of the Fundamental Processes

23-25 November 2005

Delft, The Netherlands

Organizers:

A. Scarpas
Delft University of Technology
The Netherlands

A. Papagianakis
Washington State University
USA

E. Masad
Texas A&M University
USA

www.isap-tc-conmod.org

DCMat
Delft Centre for Materials

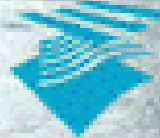

Road & Hydraulic Engineering Research
Dutch Public Works Department

TU Delft
Faculty of Civil Engineering and Geosciences



TU DELFT EARTH RESEARCH CENTRE

Technical Committee on Constitutive Modelling of Asphaltic Materials



International Workshop on
Moisture Induced Damage of Asphaltic Mixes
Characterization, Visualization and Simulation of the Fundamental Processes

23-25 November 2005
Delft, The Netherlands

Organizers:

A. Scarpas
Delft University of Technology
The Netherlands

www.isap-tc-conmod.org

DCMat
Delft Centre for Materials

TU Delft
Faculty of Civil Engineering and Geoscience

Second International Workshop on
Moisture Induced Damage of Asphalt Mixes
Characterization, Visualization and Simulation of the Fundamental Processes

September 17-19 2007

College Station, Texas (USA)

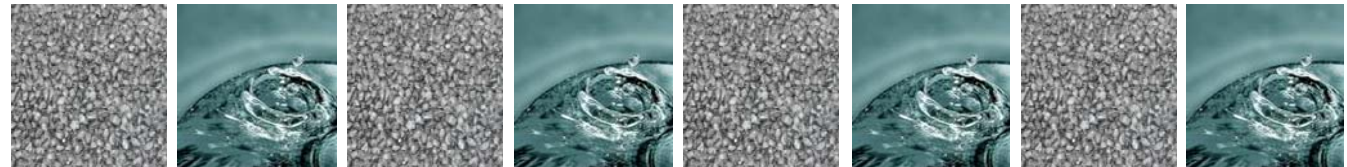

Organizers

E. Masad
D. Little
R. Lytton

Texas A&M University (USA)

A. Scarpas
Delft University of Technology
(The Netherlands)

A. Papagiannakis
University of Texas San Antonio
(USA)



TEXAS A&M
UNIVERSITY



TU Delft

UTSA

Chemical Lime
A Lhoist Group Company

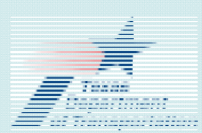

Technical Committee on Constitutive Modelling of Asphaltic Materials



International Workshop on Chemo-Mechanics of Bituminous Materials

9-11 June 2009, Delft, The Netherlands

Edited by Niki Kringos



Technical Committee on Constitutive Modelling of Asphaltic Materials



- Foam Asphalt Concrete
Loizos & Jennings
- Chemo-Mechanics of
Bituminous Materials
Pauli
- Moisture Induced Damage
in Asphaltic Materials
Masad & Kringos
- Micro-Mechanics of
Asphalt Concrete Mixes
Wang

Technical Committee on Constitutive Modelling of Asphaltic Materials



10th INTERNATIONAL
CONFERENCE ON
ASPHALT PAVEMENTS

*Aug 12 - 17, 2006
A Rendezvous you
simply can't miss*



Québec, Canada

Call for Papers

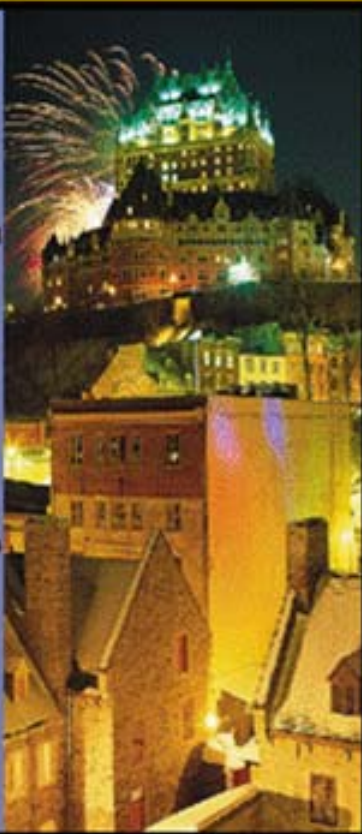

During the 10th ICAP Conference
the TC has focussed sessions on:

Session No.	Session Topic	Sponsored by
Session 1.8	Foamed Mix	WG 01
Session 1.9	Water Damage	WG 02
Session 1.10	Asphalt Cracking/ Constitutive Modeling	TC
Session 1.11	Asphalt Reinforcement	WG 04

For more info please visit www.icap2006.fsg.ulaval.ca

Technical Committee on Constitutive Modelling of Asphaltic Materials



National
Technical
University of
Athens

TU Delft
Delft University of Technology

I
ILLINOIS



International Conference: Advanced Characterisation of Pavement and Soil Engineering Materials

20 - 22 June 2007
Athens, Greece

WWW.3DFEM.ORG

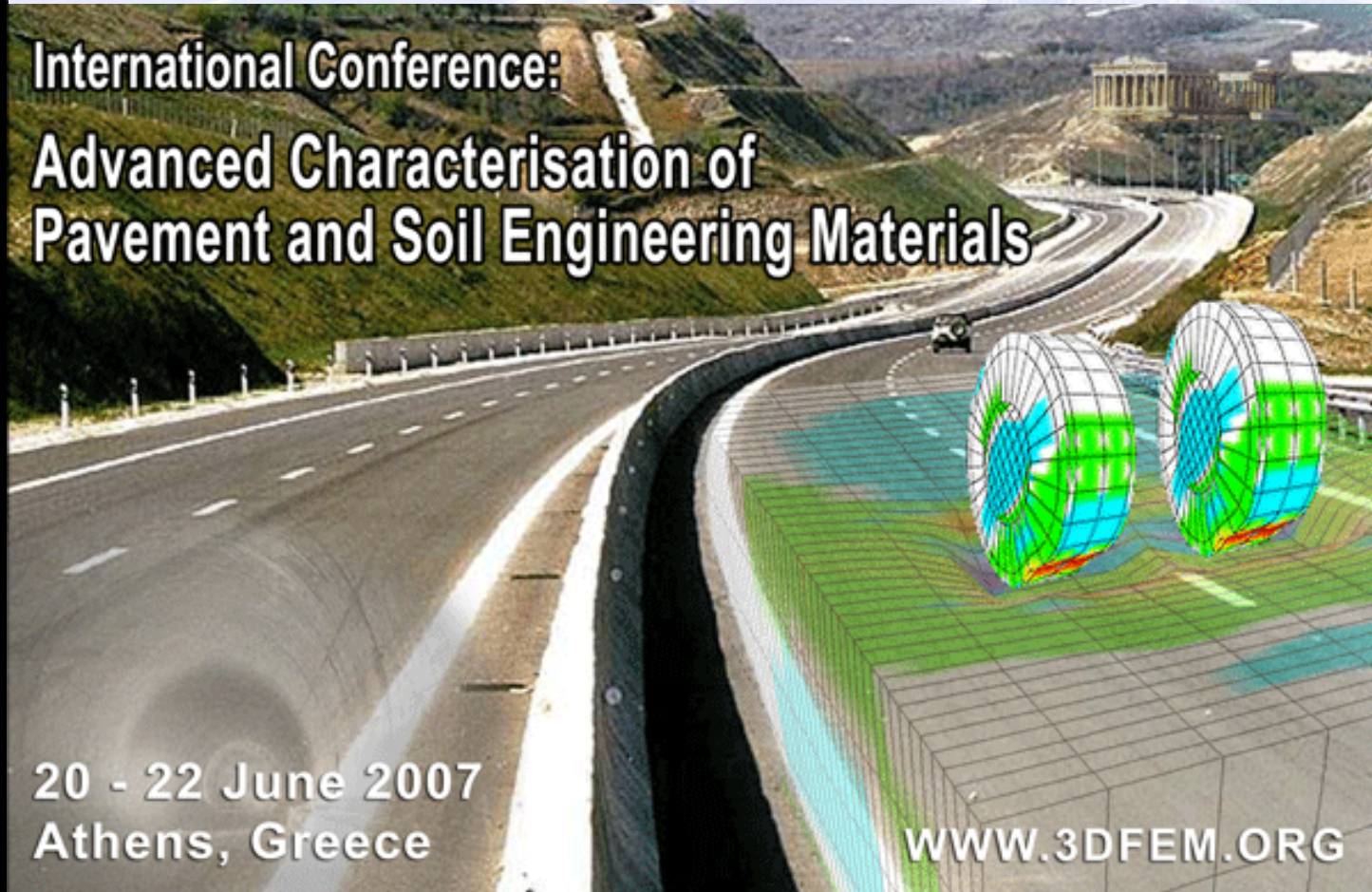

Technical Committee on Constitutive Modelling of Asphaltic Materials

www.isap-tc-conmod.org



HOME

ISAP TC

WG's

EVENTS

NEWS

LINKS

FORUM

CONTACT

Welcome at the official site of the:

**Technical Committee on Constitutive
Modelling of Asphaltic Materials.**

This ISAP TC was inaugurated
on the 29th of July 2003 in Corfu, Greece.



- **50 members from 12 different countries**
- **Annual TC Board meeting during TRB**



Development of a Physico-Mechanical Healing Model for Bituminous Materials

Tom Scarpas

Group of Mechanics of Infrastructure Materials

Section of Structural Mechanics

Faculty of Civil Engineering and Geosciences

TU Delft



Development of a Physico-Mechanical Healing Model for Bituminous Materials

N. Kringos, T. Pauli, A. Schmets

Group of Mechanics of Infrastructure Materials

Section of Structural Mechanics

Faculty of Civil Engineering and Geosciences

TU Delft



Ministerie van Verkeer en Waterstaat
Rijkswaterstaat



Ooms
Avenhorn Groep bv



Western Research
INSTITUTE

 **TU Delft**



U.S. Department of Transportation
Federal Highway Administration

DCMat

Delft Centre for Materials



Development of a Physico-Mechanical Healing Model for Bituminous Materials

Delft Healing Consortium

Group of Mechanics of Infrastructure Materials

Section of Structural Mechanics

Faculty of Civil Engineering and Geosciences

TU Delft

Neutron scattering

X-Ray scans

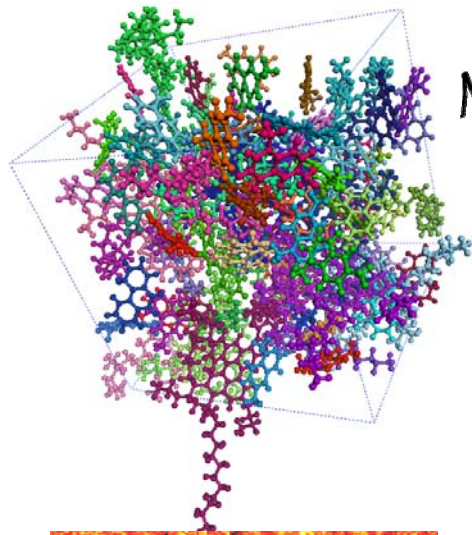

Molecular dynamics

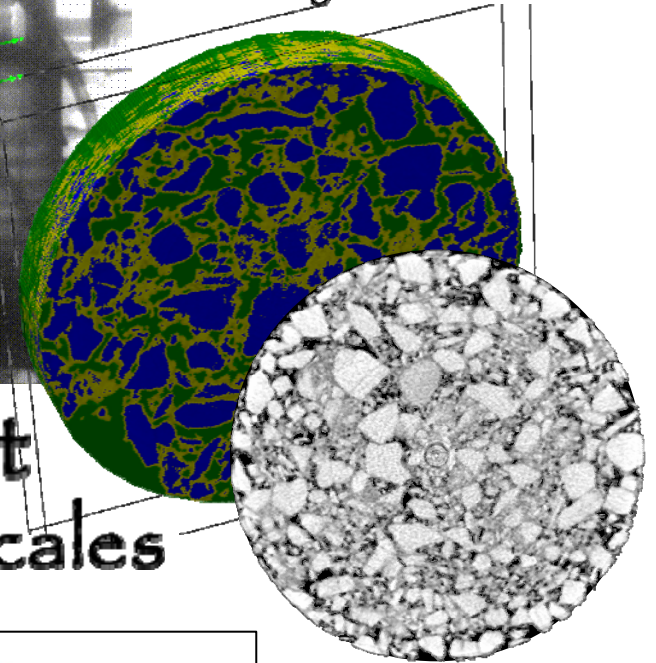
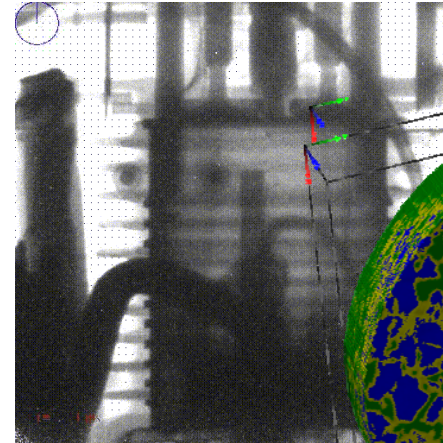
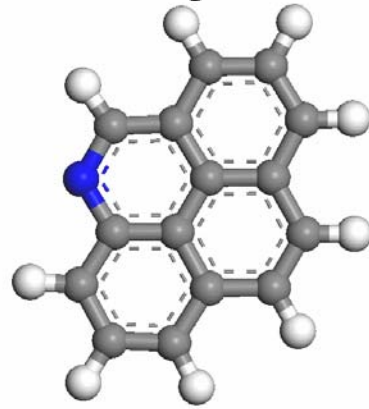

Healing of asphalt

...research on all scales

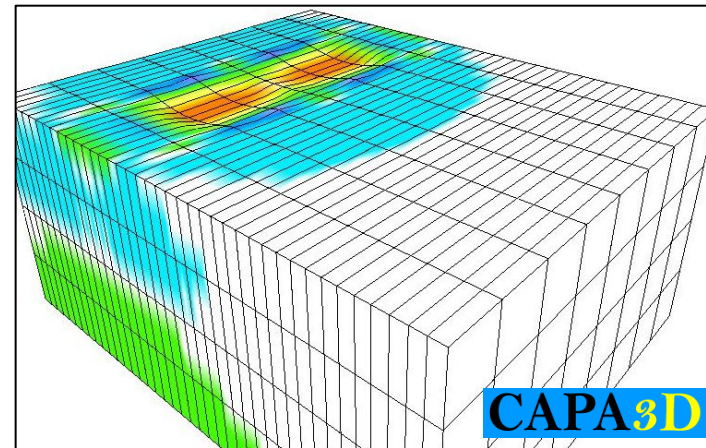
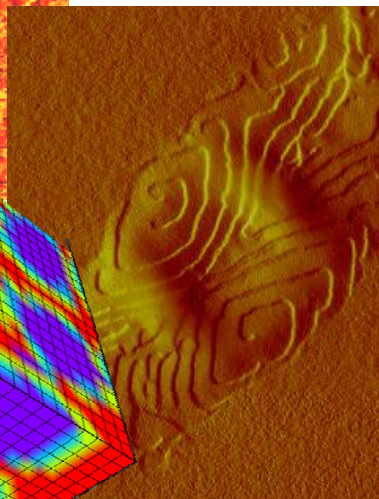
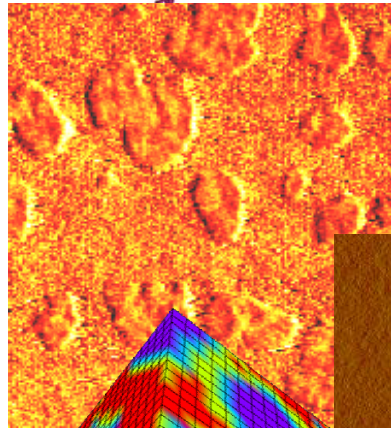

Finite Elements

CAPA3D

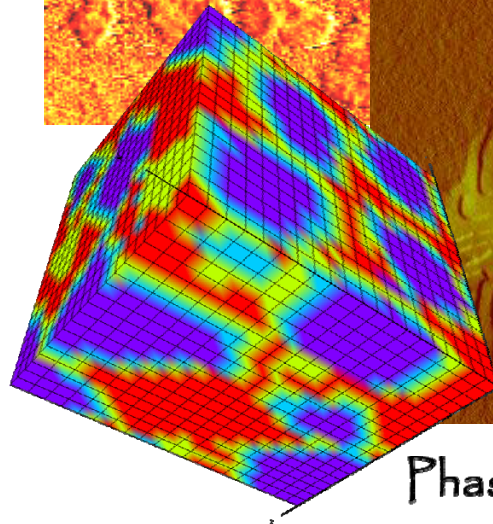
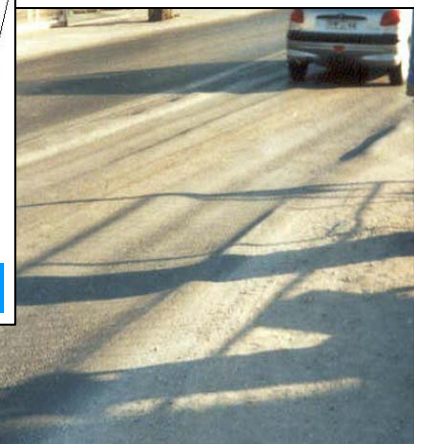

Phase behaviour

Pavement response

Neutron scattering

X-Ray scans

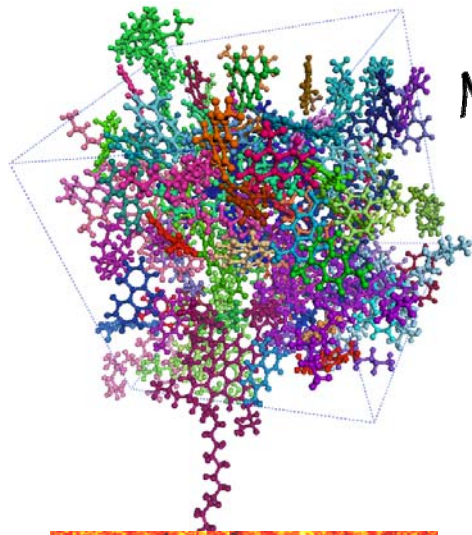

Molecular dynamics

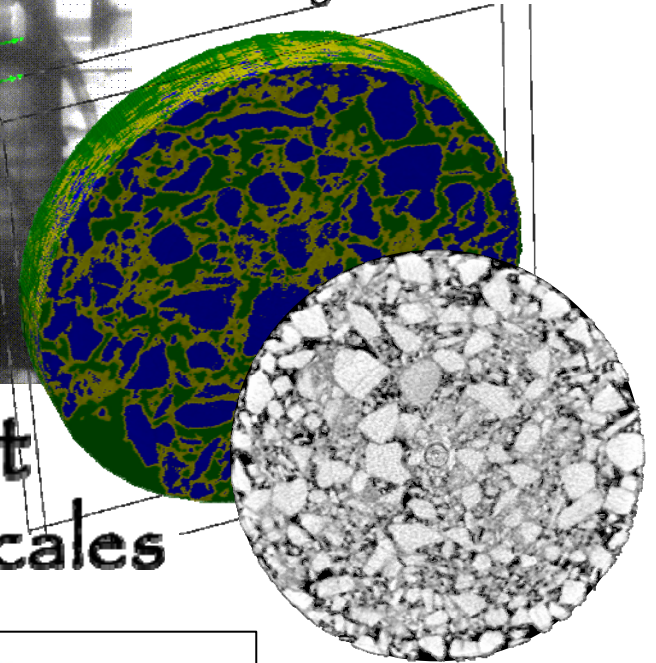
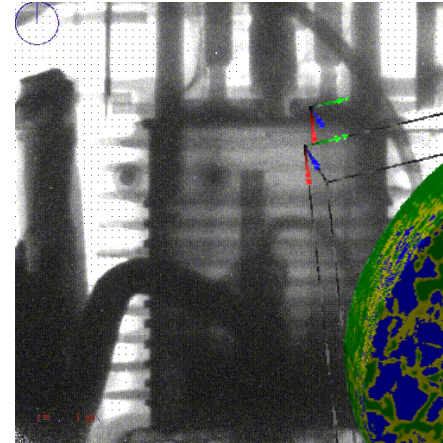
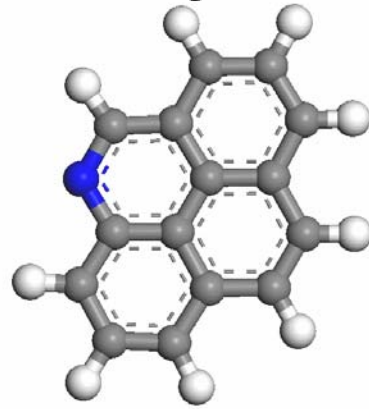

Healing of asphalt

...research on all scales

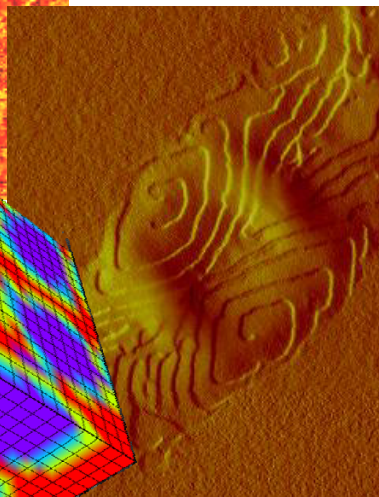
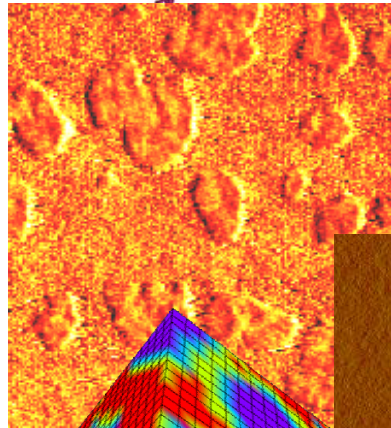

Phase behaviour

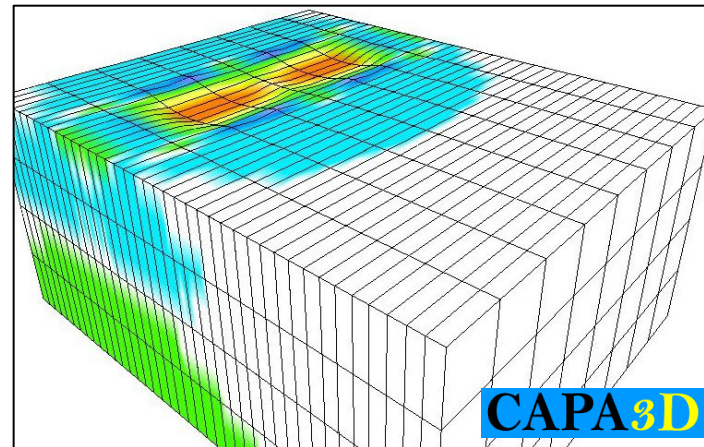

Pavement response

CAPA3D

Finite Elements

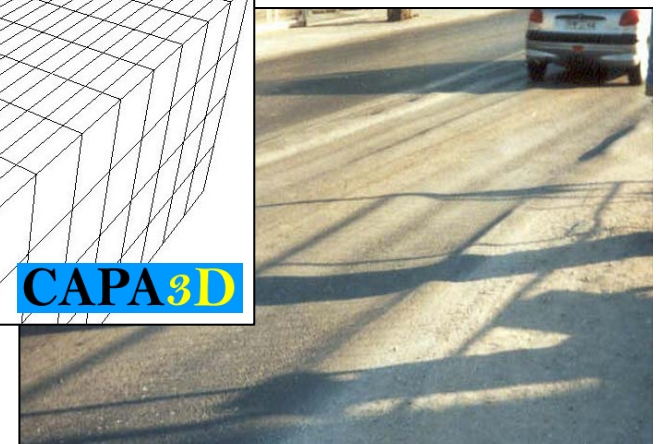

Neutron scattering

X-Ray scans

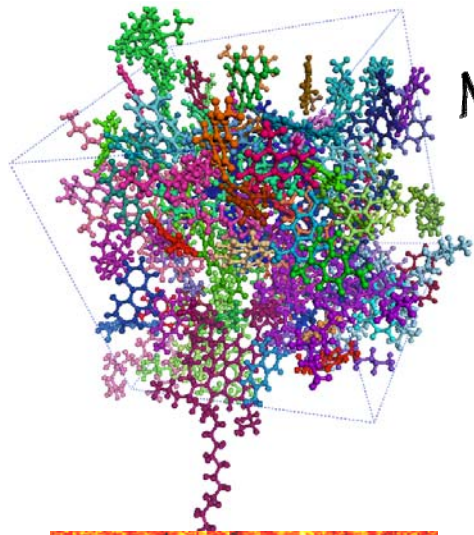

Molecular dynamics

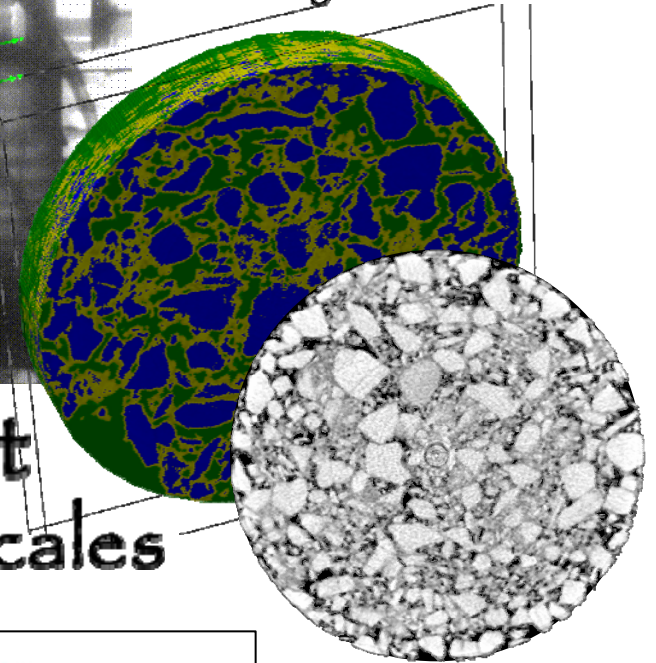
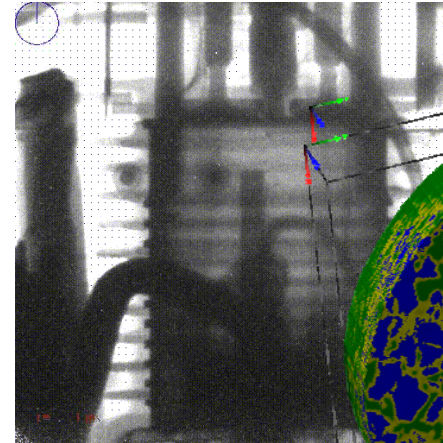
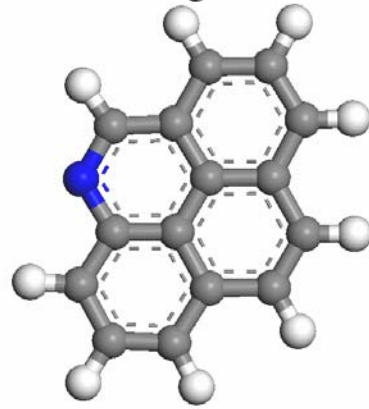

Healing of asphalt

...research on all scales

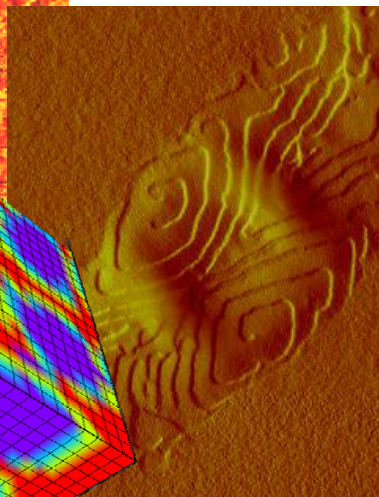
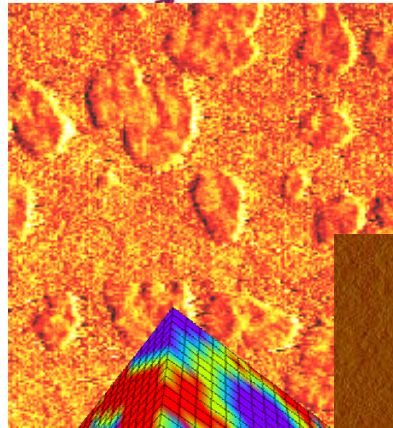

Phase behaviour

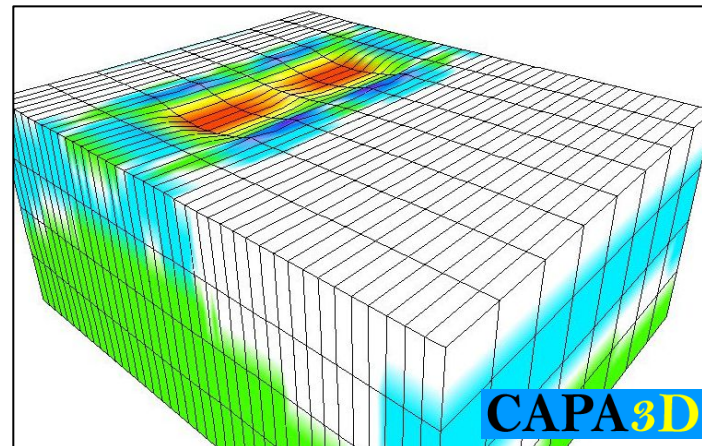

Pavement response

Finite Elements

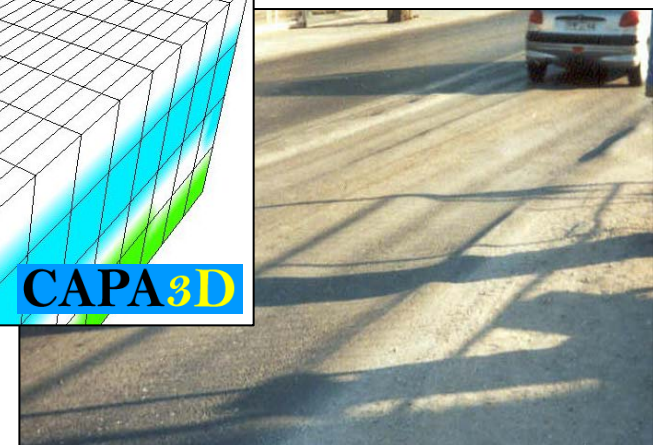

Neutron scattering

X-Ray scans

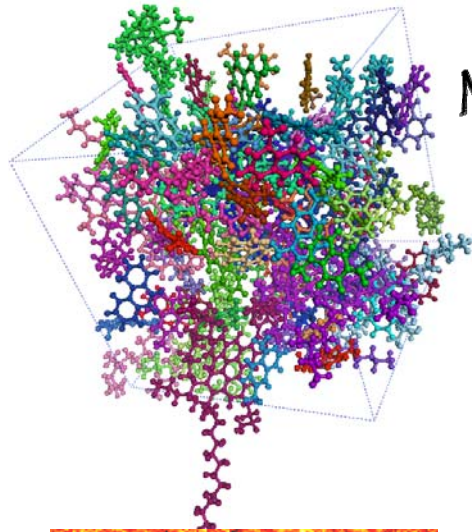

Molecular dynamics

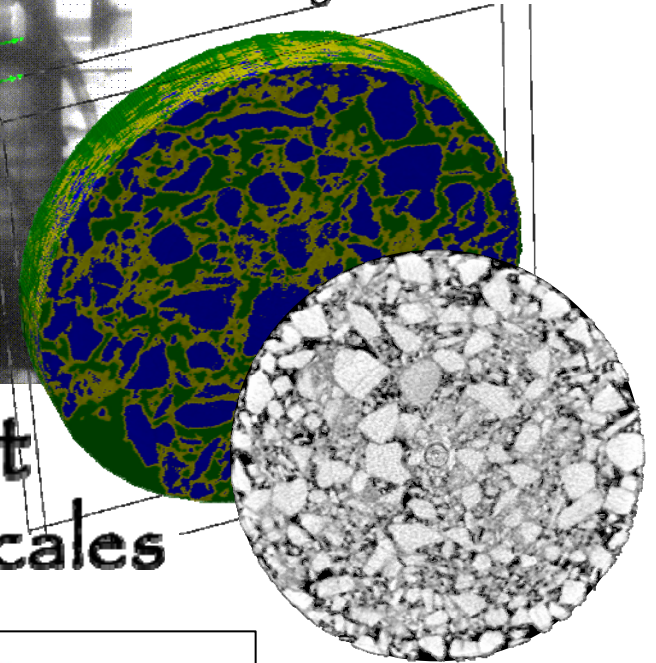
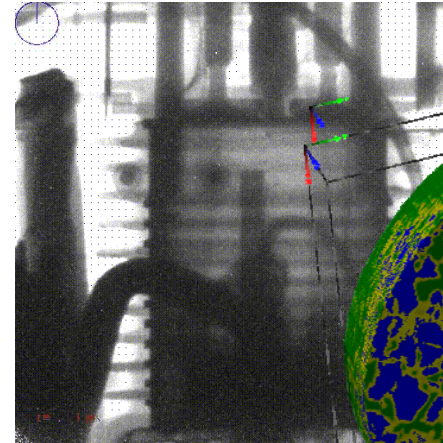
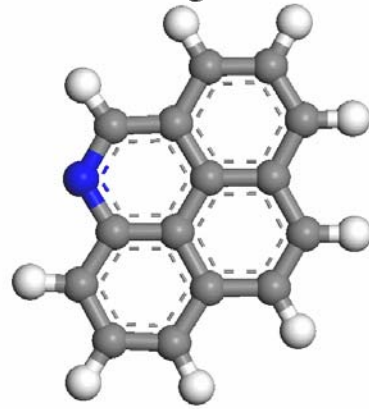

Healing of asphalt

...research on all scales

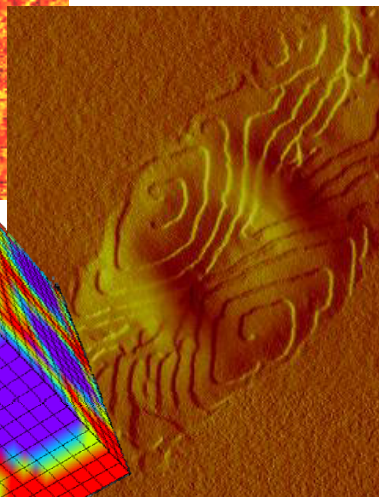
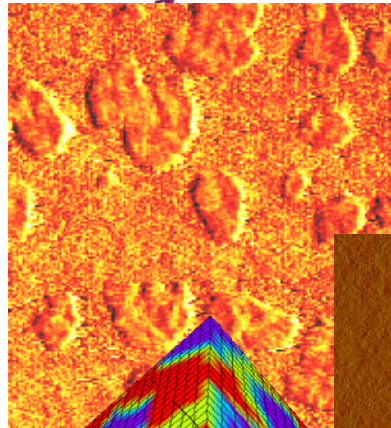

Phase behaviour

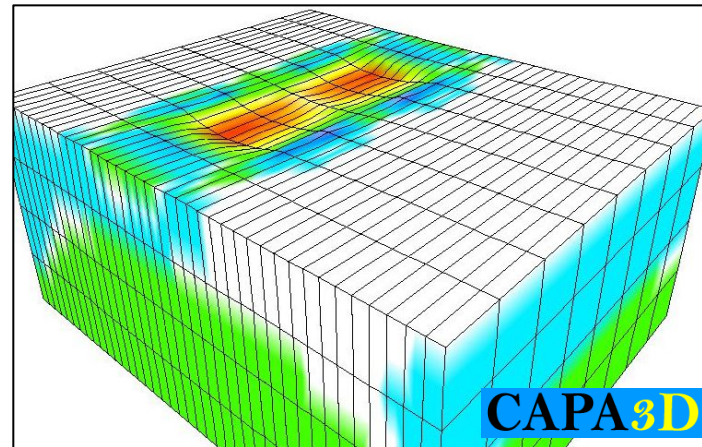

Pavement response

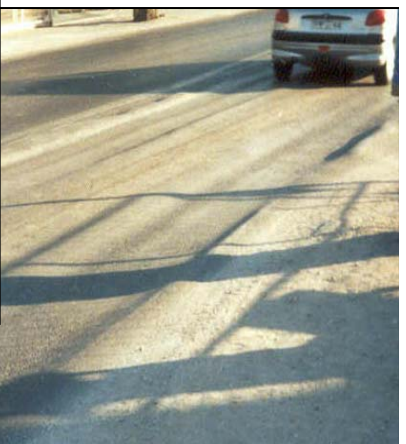

Finite Elements

Neutron scattering

X-Ray scans

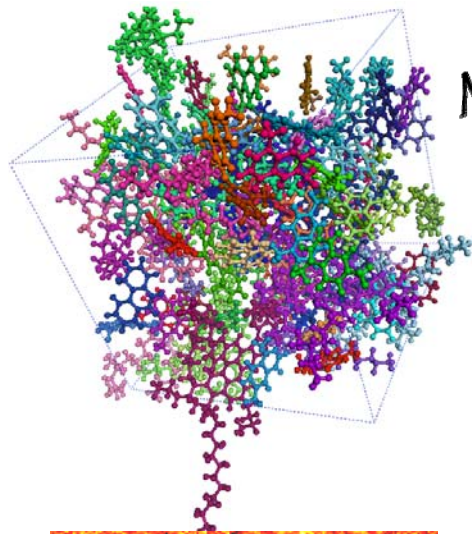

Molecular dynamics

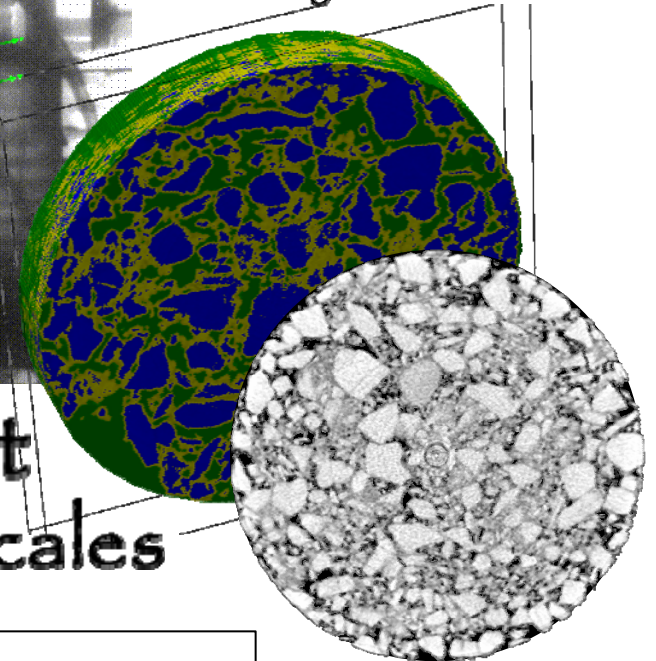
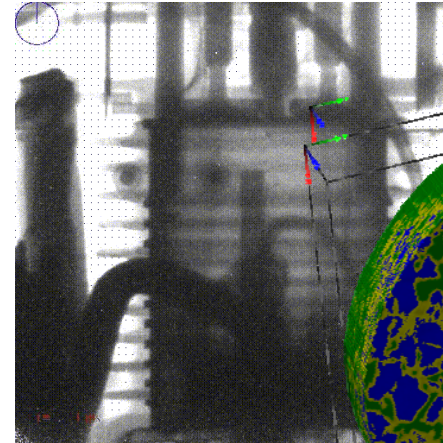
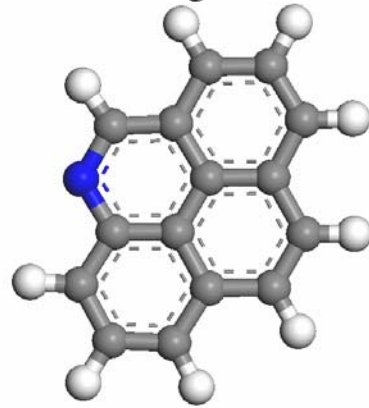

Healing of asphalt

...research on all scales

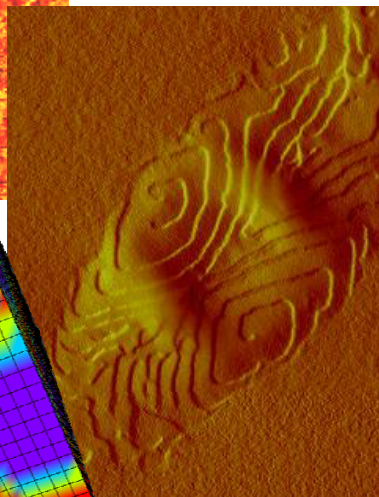
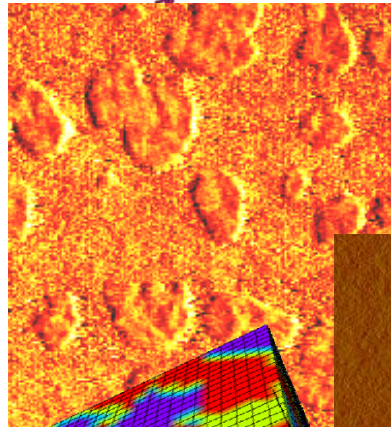

Phase behaviour

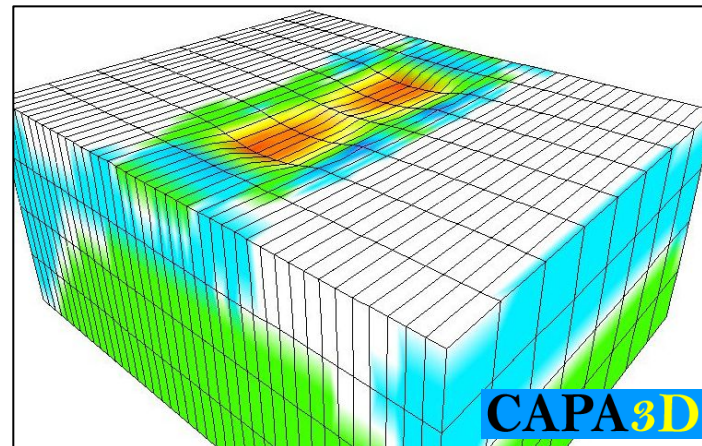

Pavement response

CAPA3D

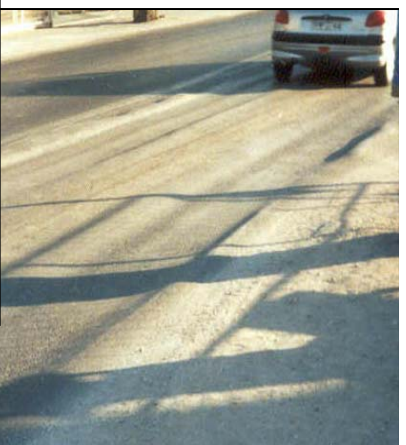

Finite Elements

Neutron scattering

X-Ray scans

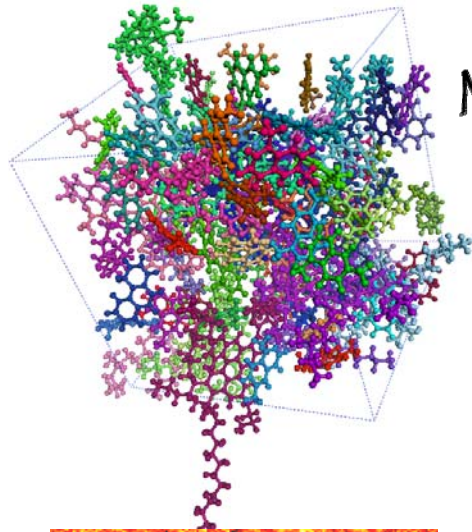

Molecular dynamics

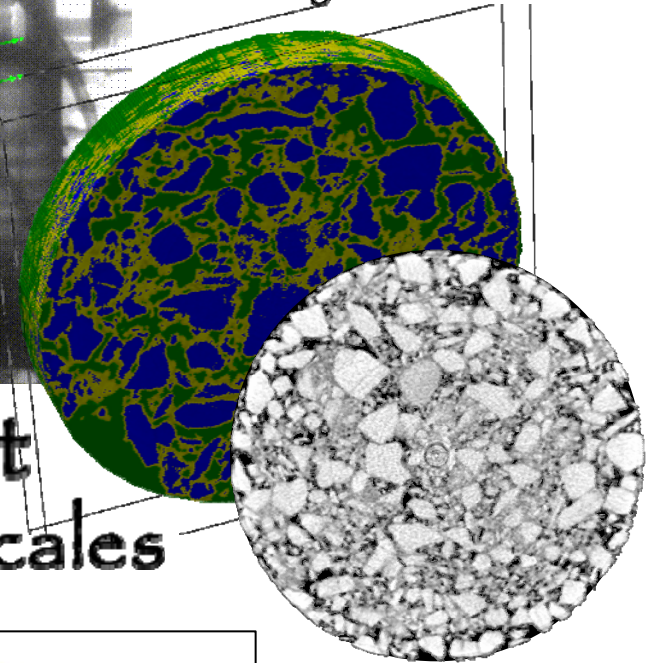
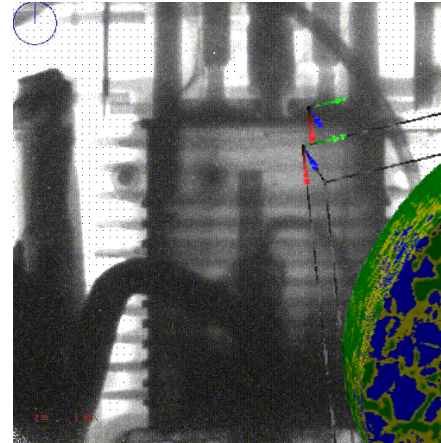
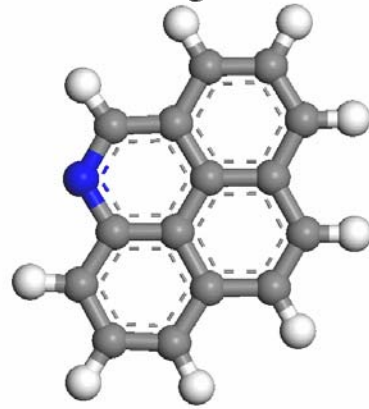

Healing of asphalt

...research on all scales

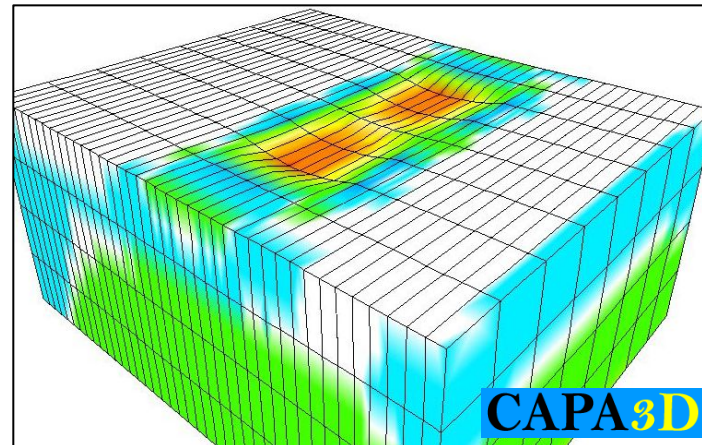
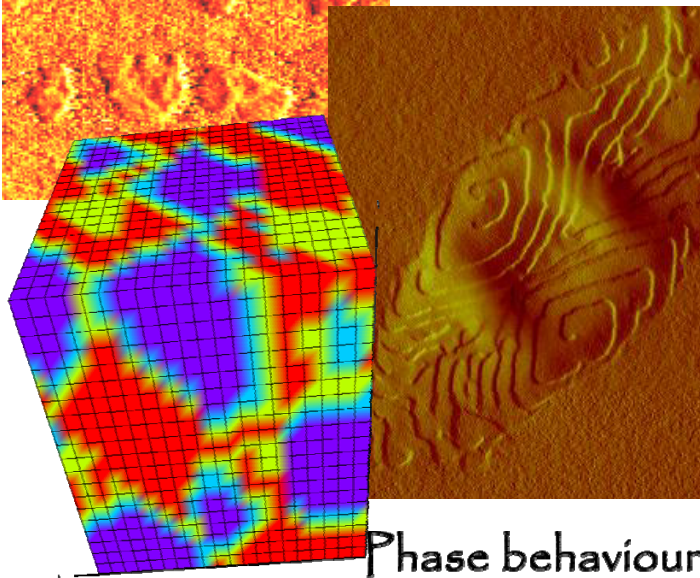
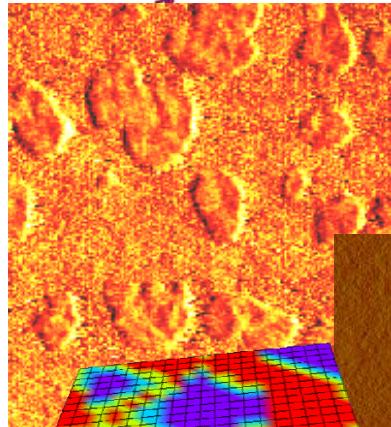

Pavement response

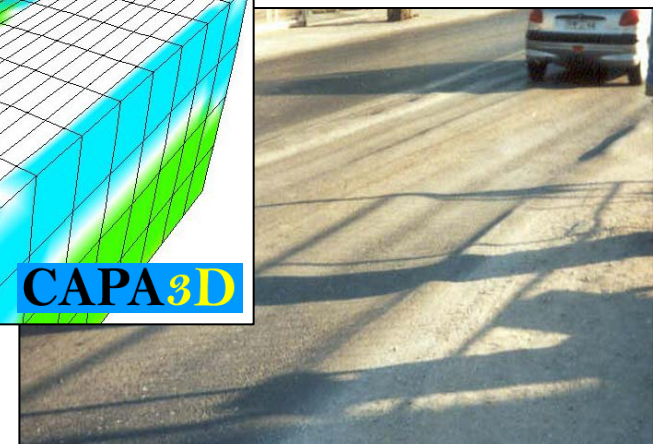

Neutron scattering

X-Ray scans

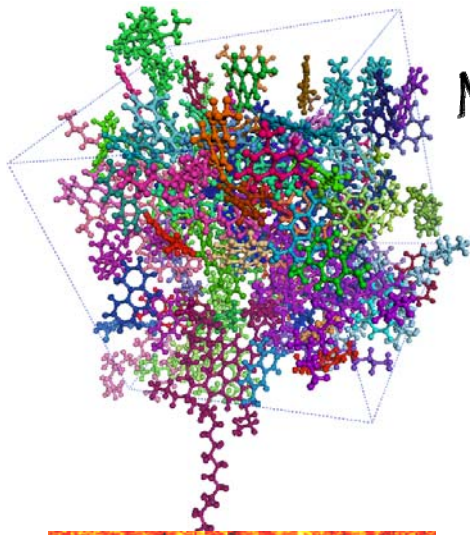

Molecular dynamics

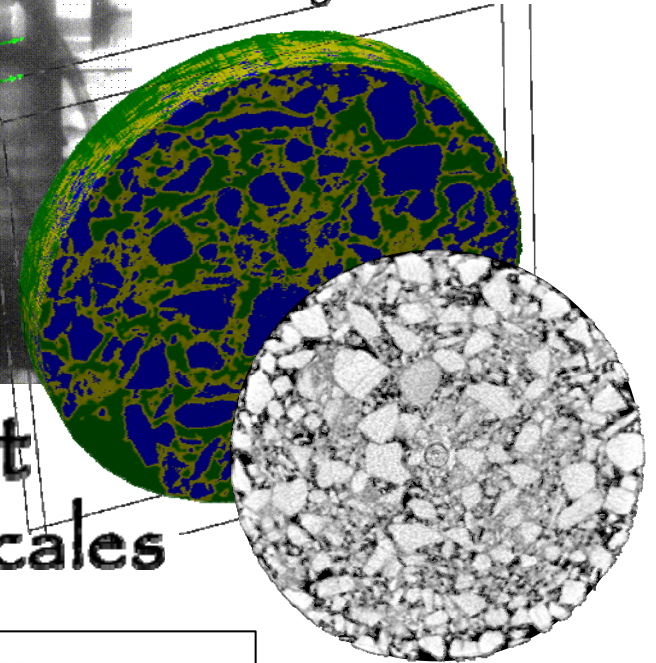
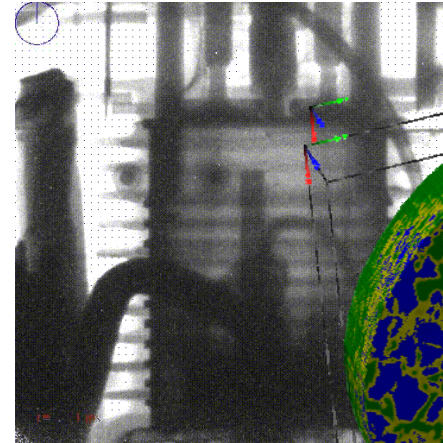
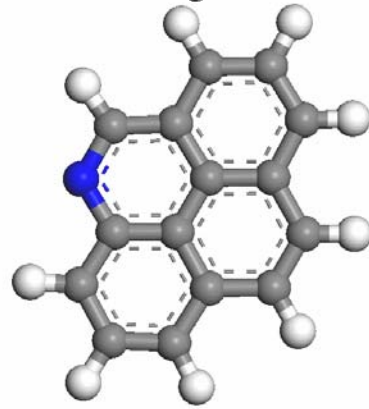

Healing of asphalt

...research on all scales

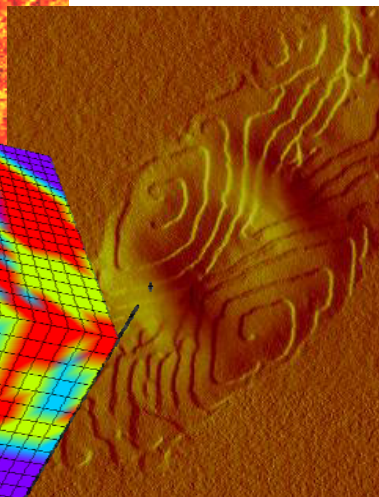
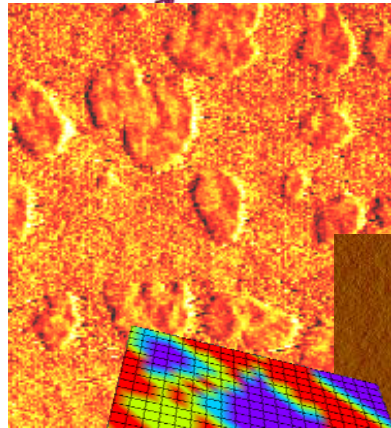

Phase behaviour

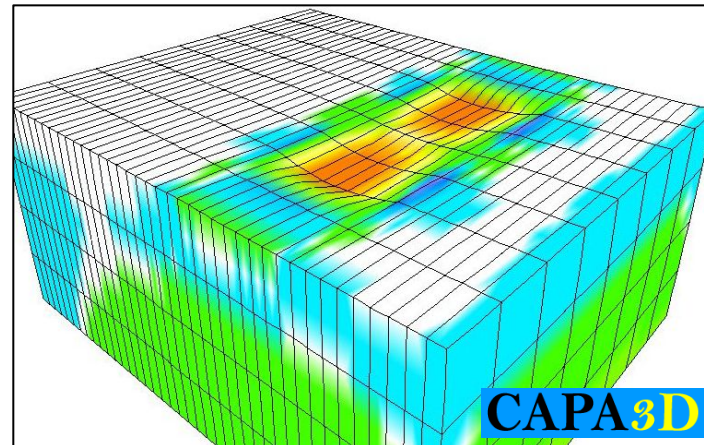

CAPA3D

Pavement response

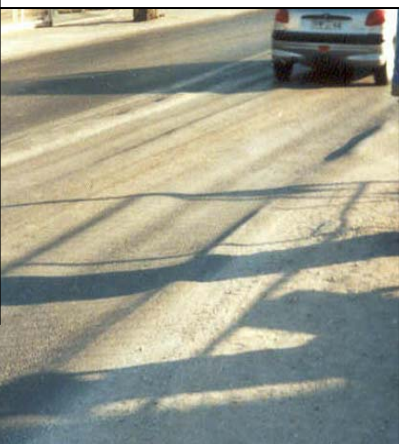

Finite Elements

Neutron scattering

X-Ray scans

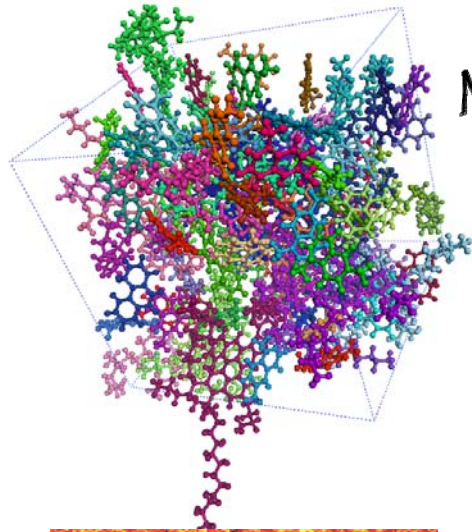

Molecular dynamics

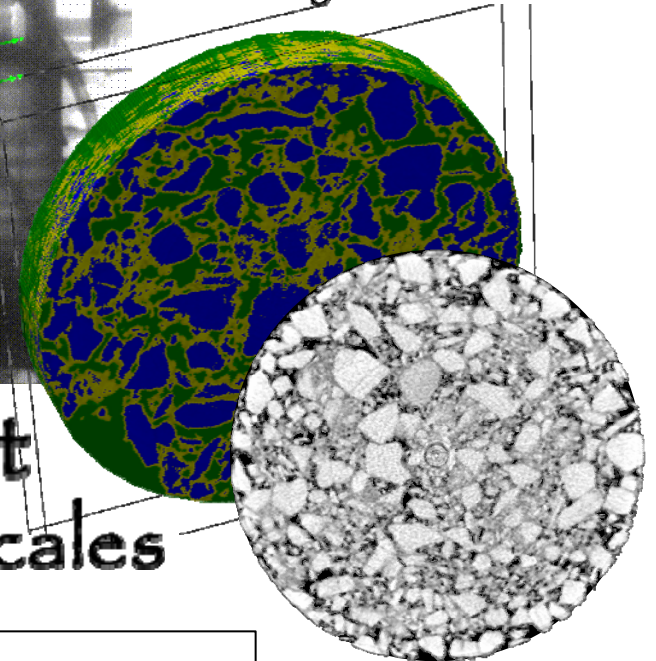
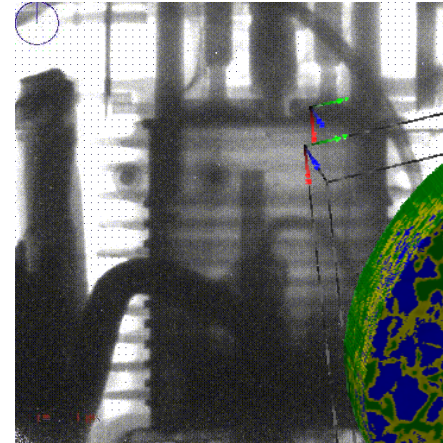
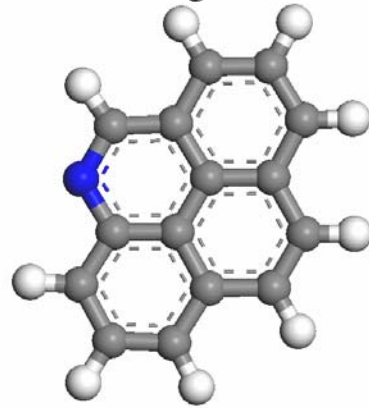

Healing of asphalt

...research on all scales

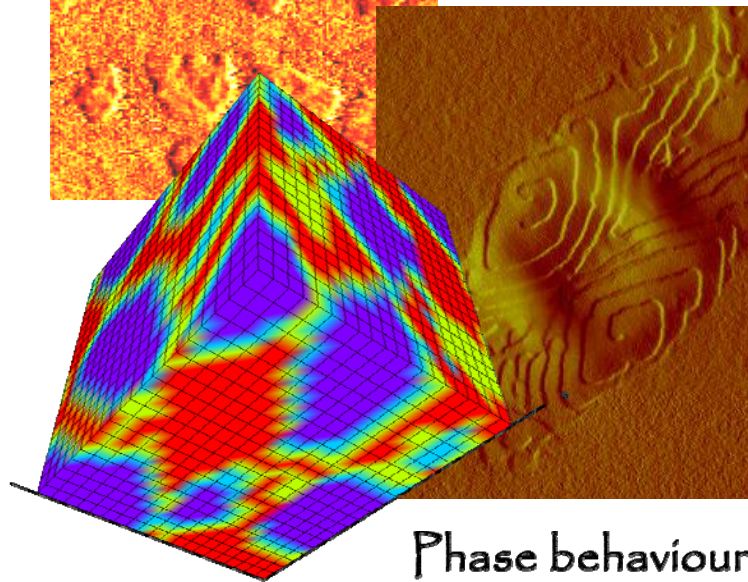
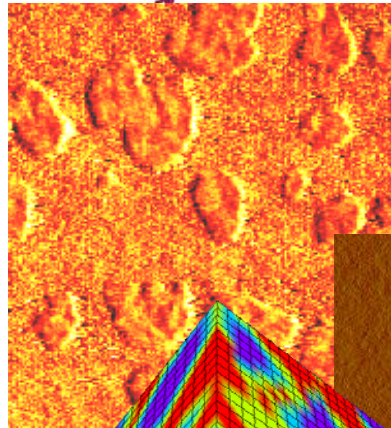

Phase behaviour

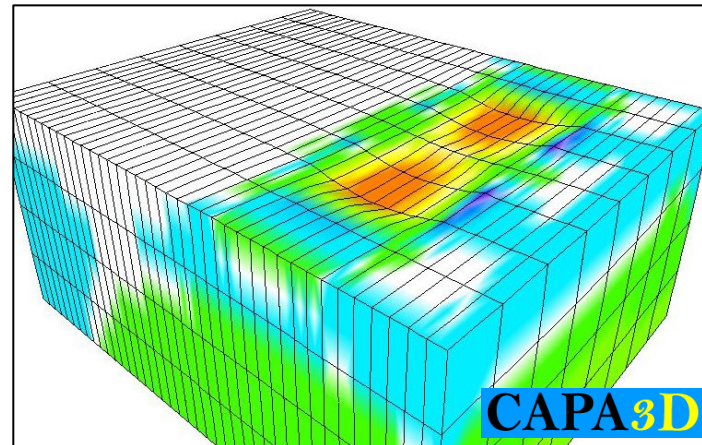

Pavement response

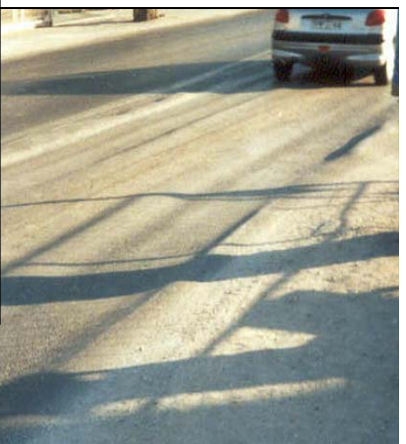

Finite Elements

Neutron scattering

X-Ray scans

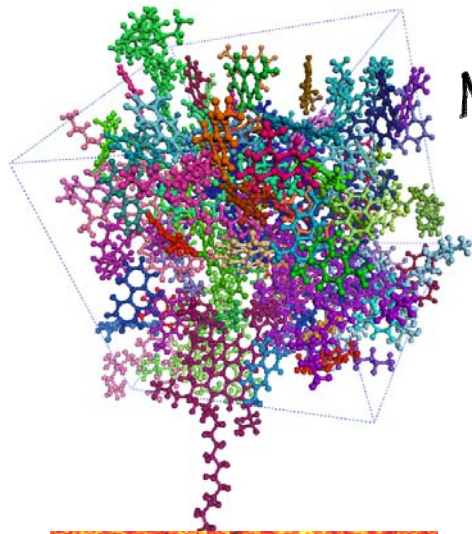

Molecular dynamics

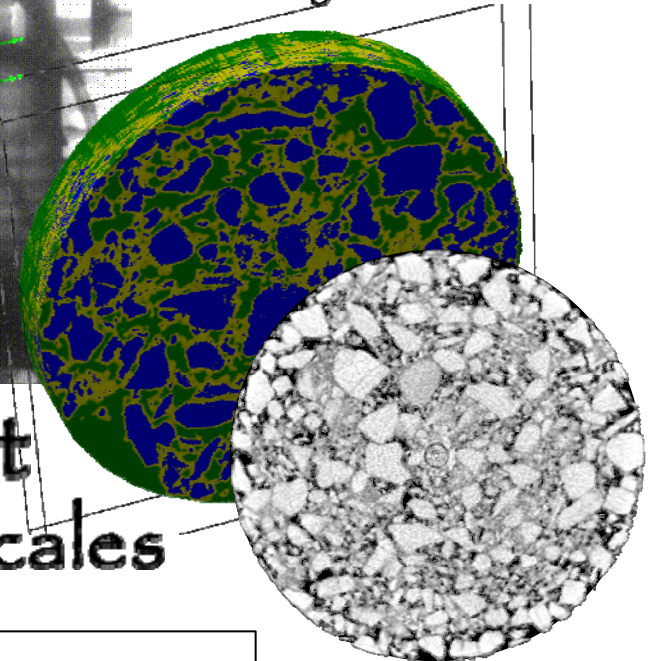
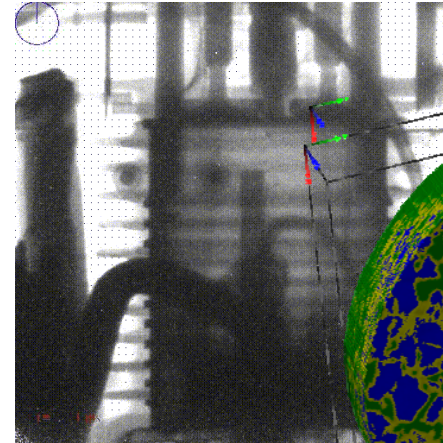
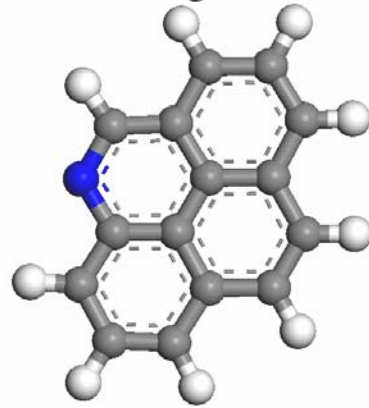

Healing of asphalt

...research on all scales

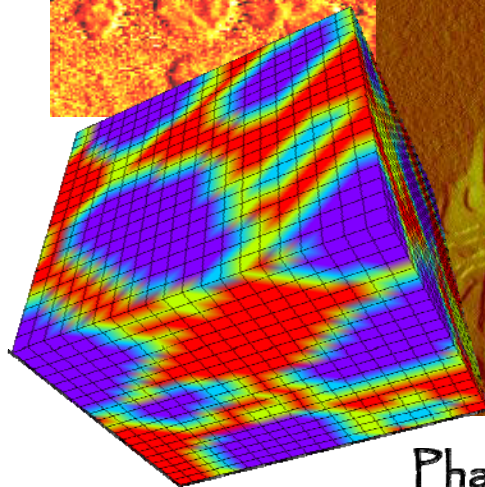
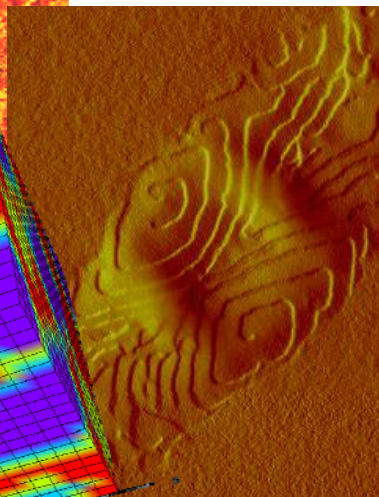
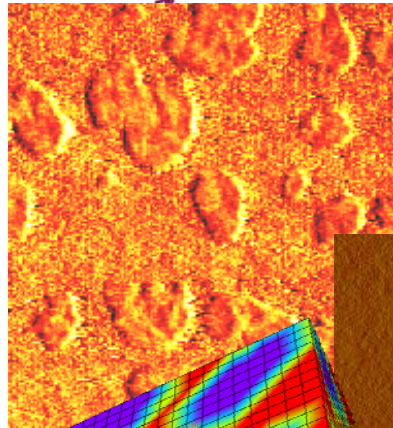

Phase behaviour

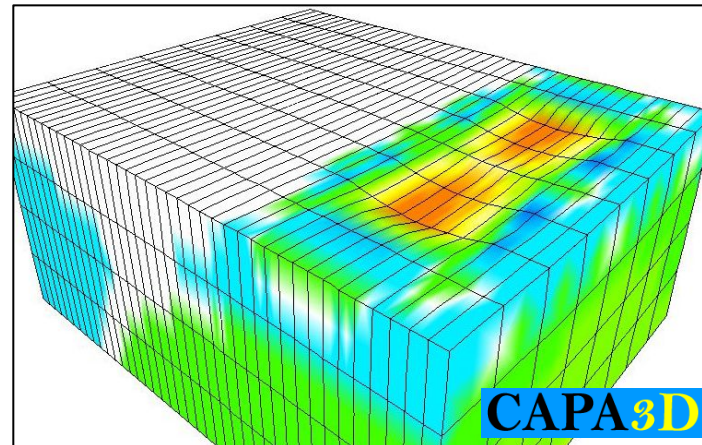

Pavement response

CAPA3D

Finite Elements

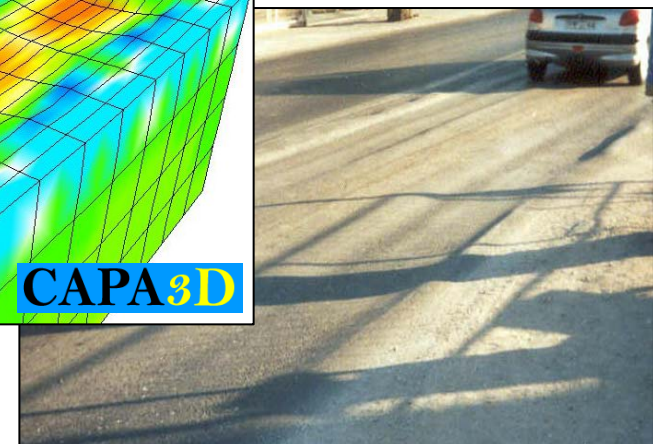

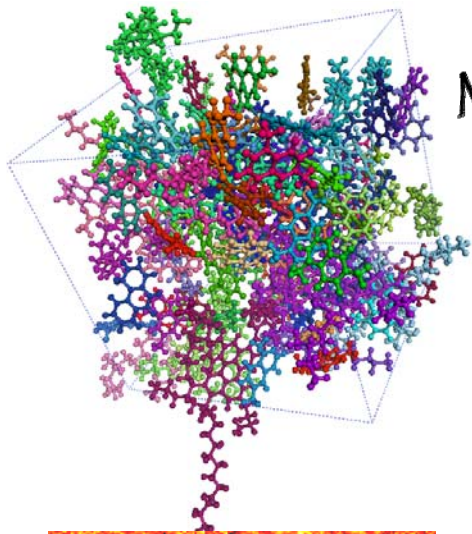

Molecular dynamics

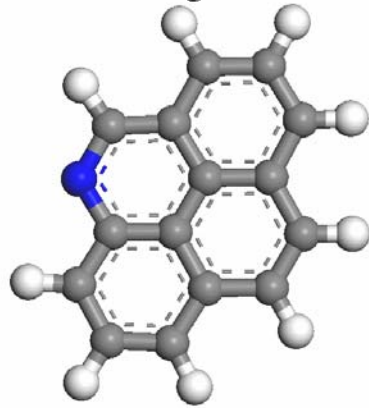

Neutron scattering

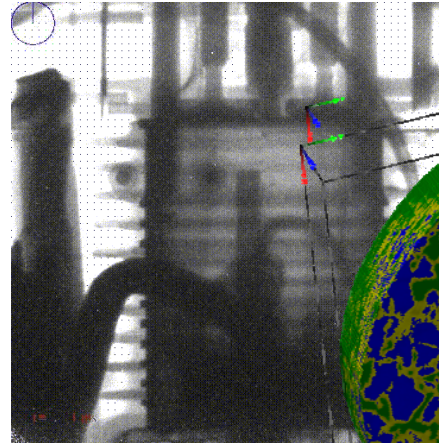

X-Ray scans

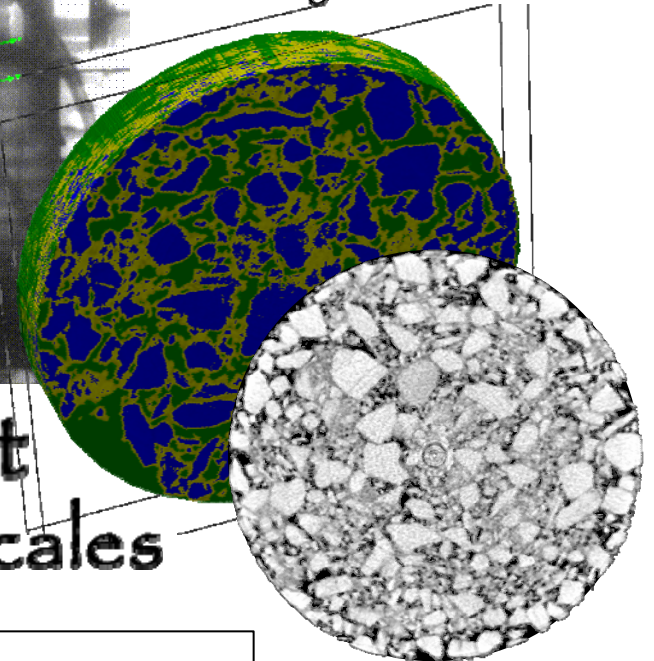

Healing of asphalt

...research on all scales

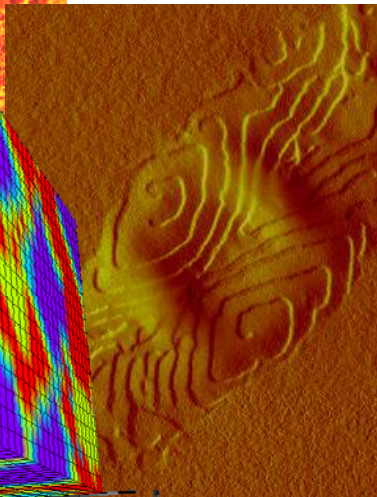
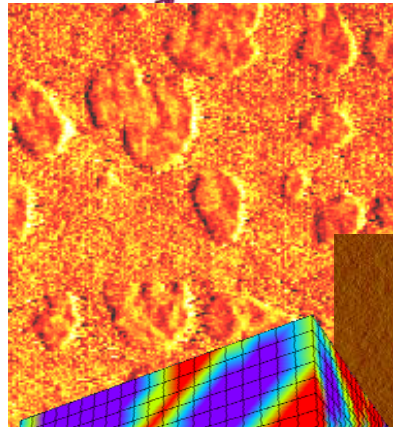

Phase behaviour

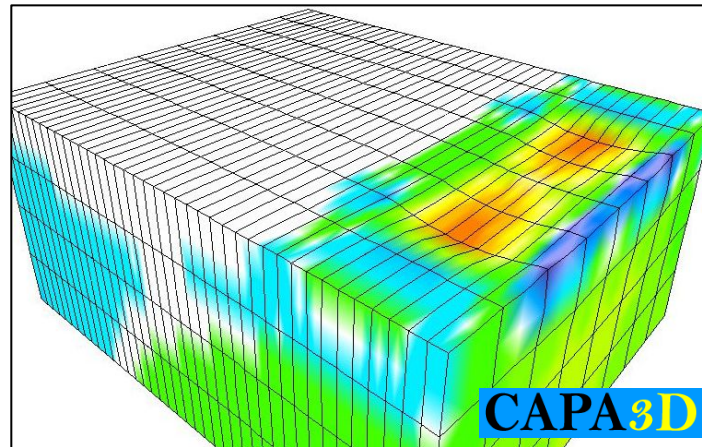

Pavement response

CAPA3D

Finite Elements

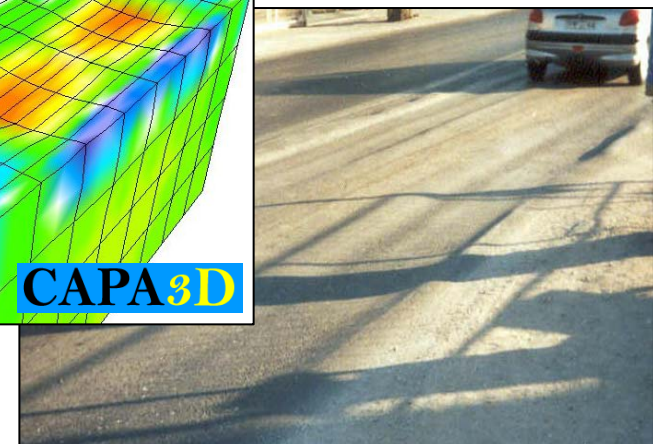

G^* [Pa]

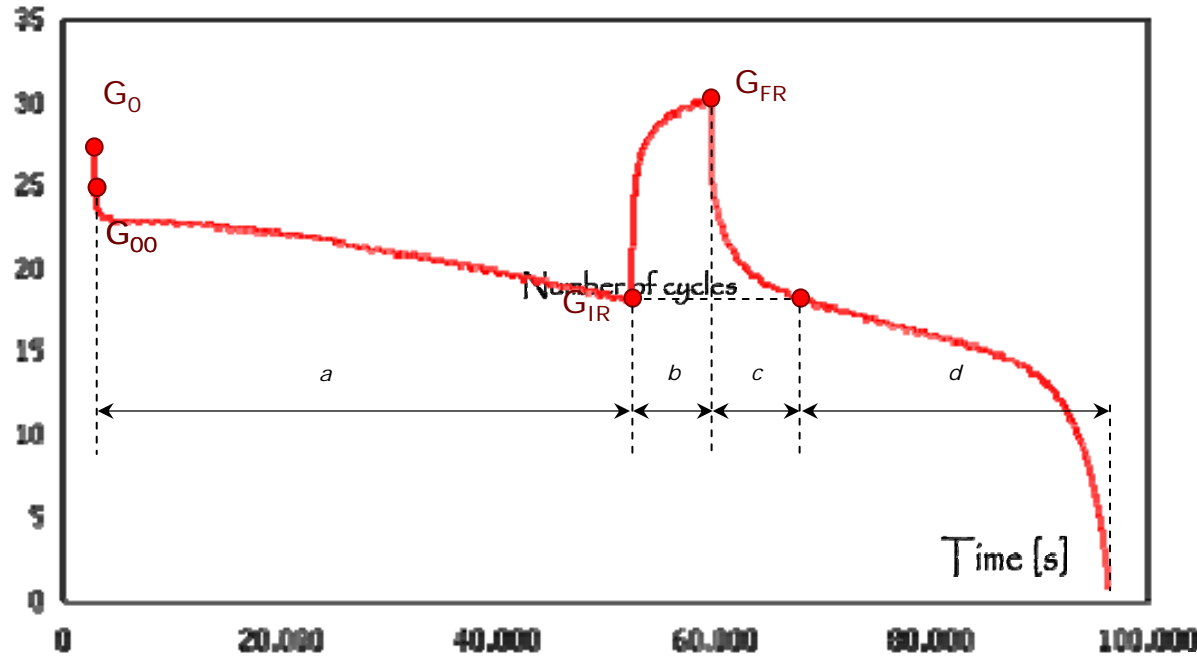

(T santilis & Santagata)

Bitumen

IS

Self Healing

- WHY does it occur?

Bitumen

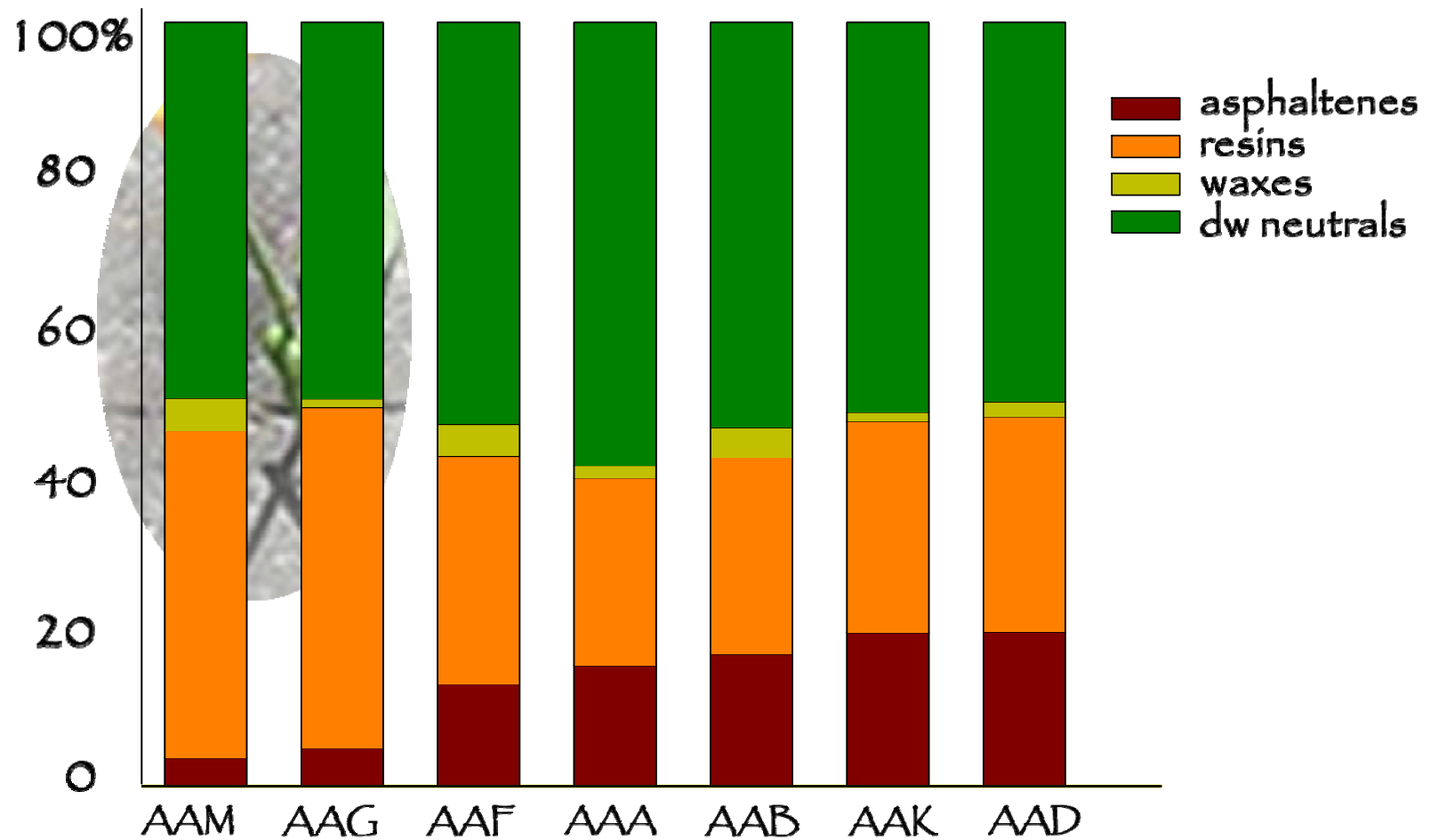

(Pauli @ WRD)

Bitumen under the AFM

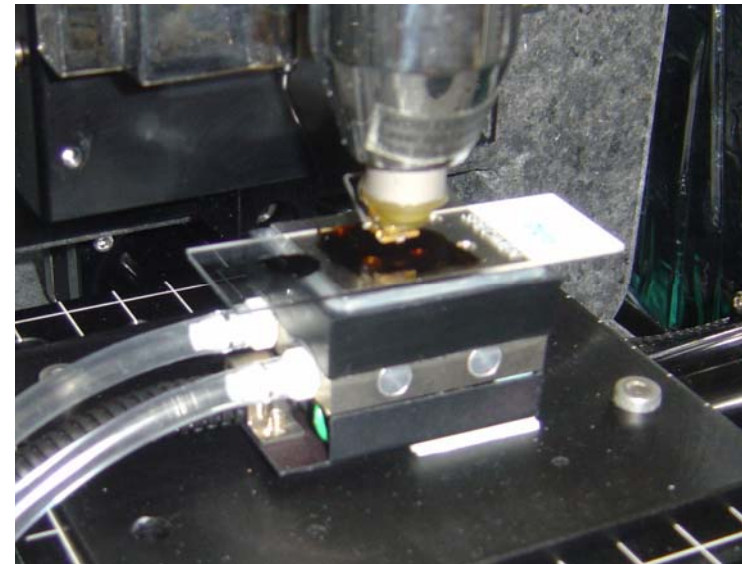

(phase image)

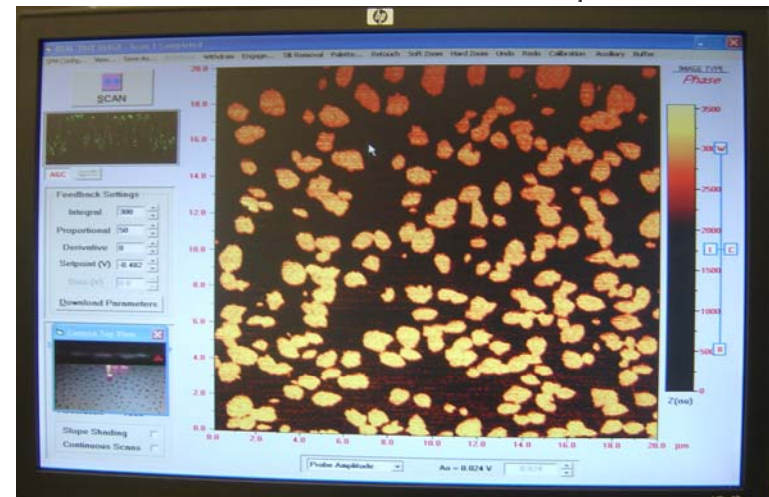
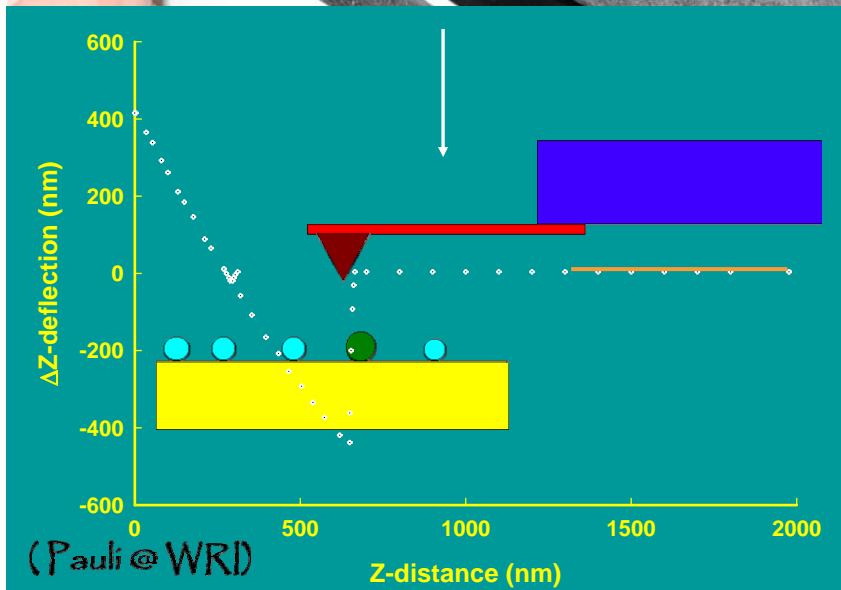

Bitumen under the AFM

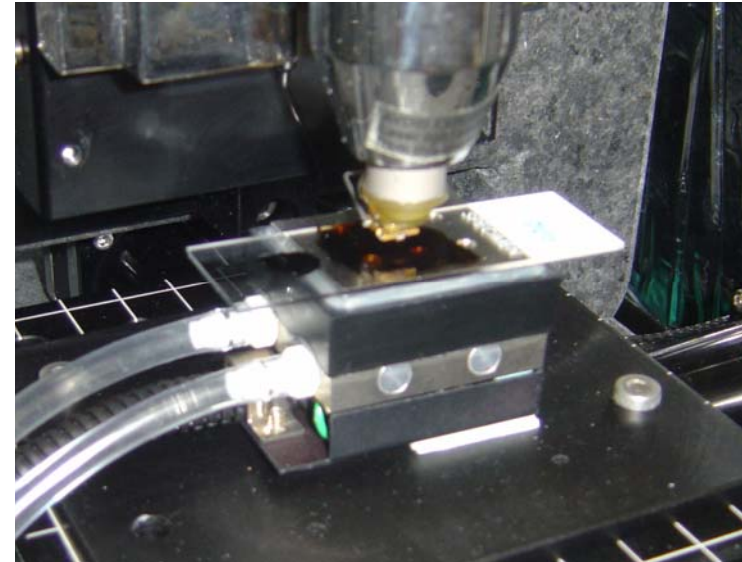

(phase image)

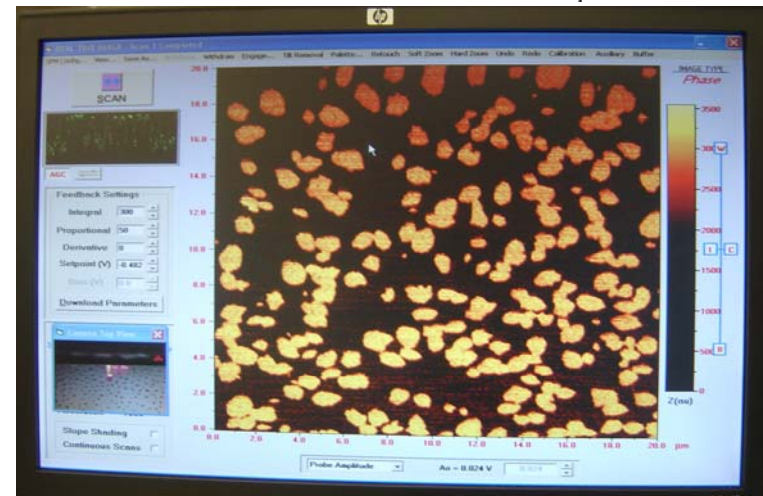
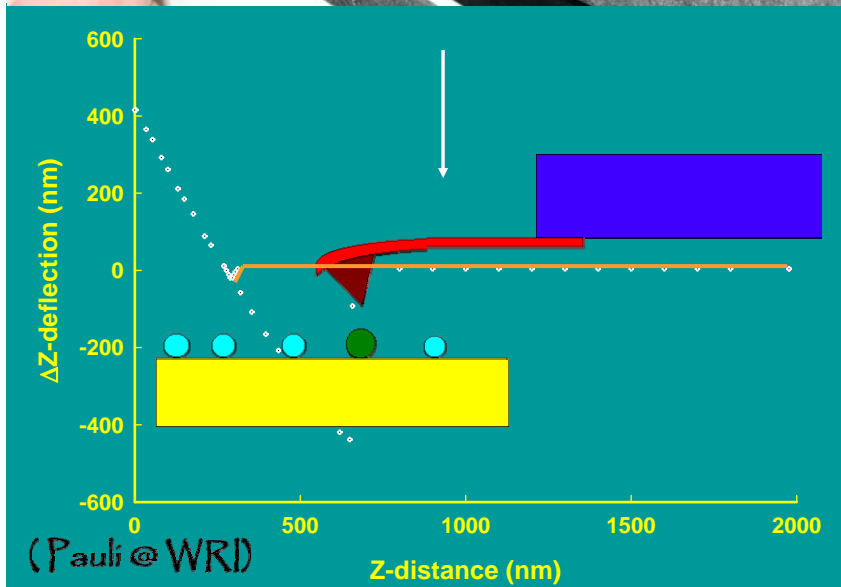

Bitumen under the AFM

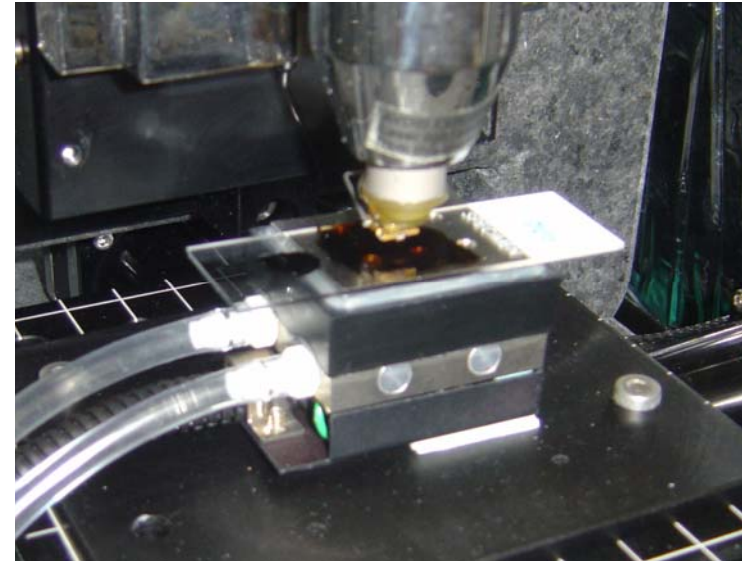

(phase image)

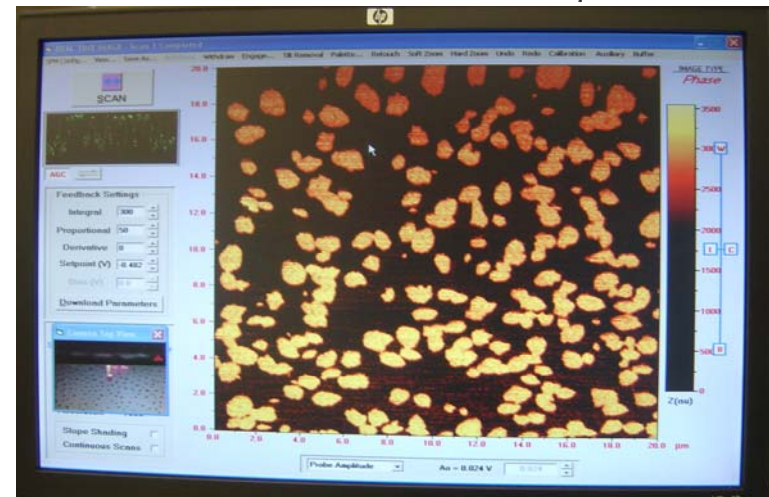
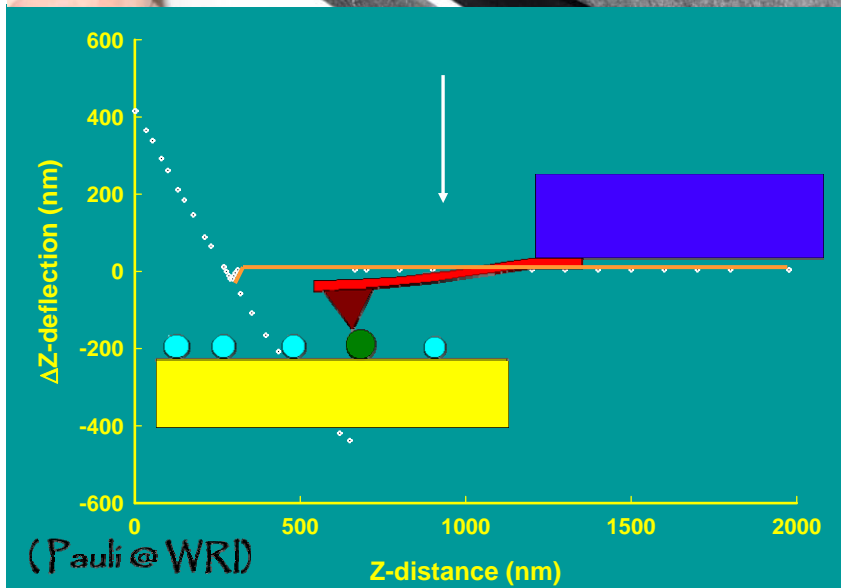

Bitumen under the AFM

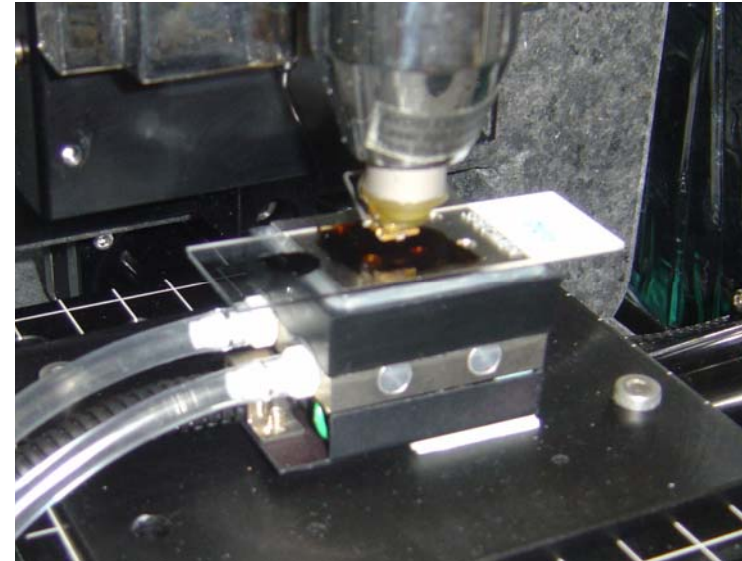

(phase image)

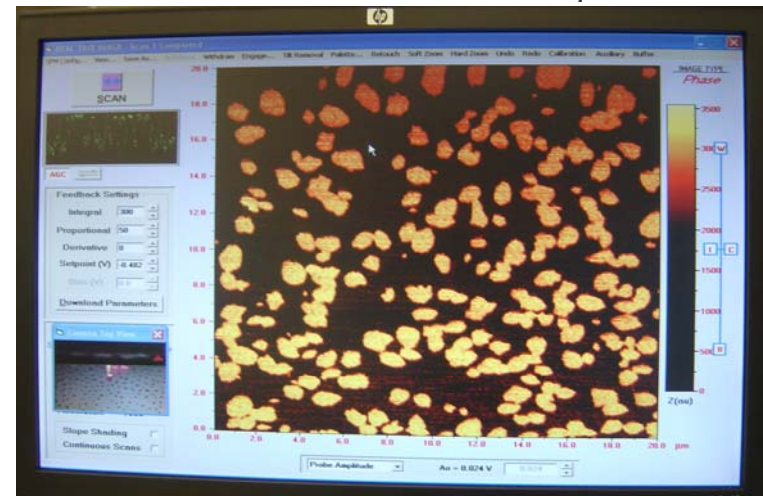
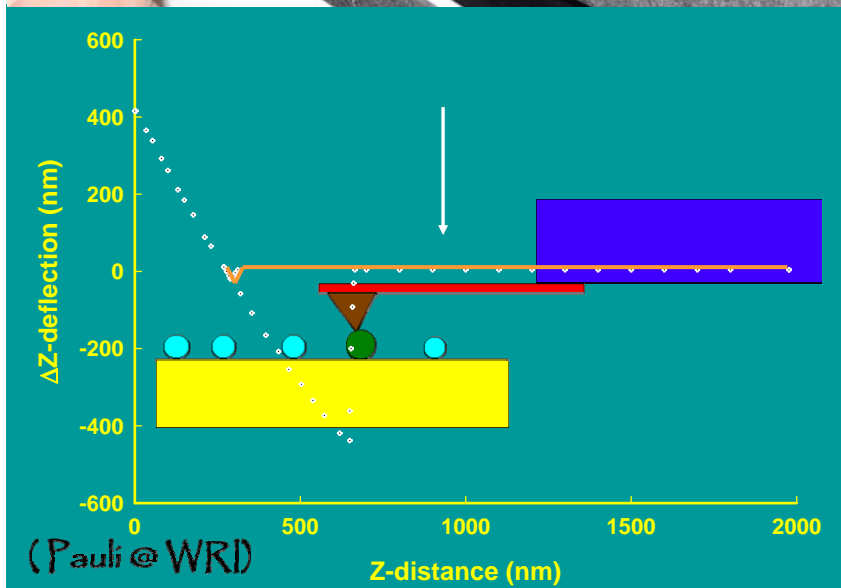

Bitumen under the AFM

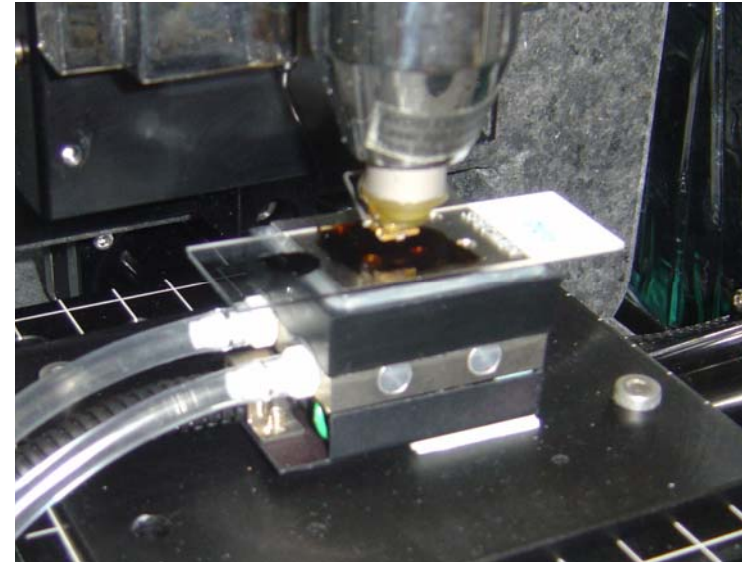

(phase image)

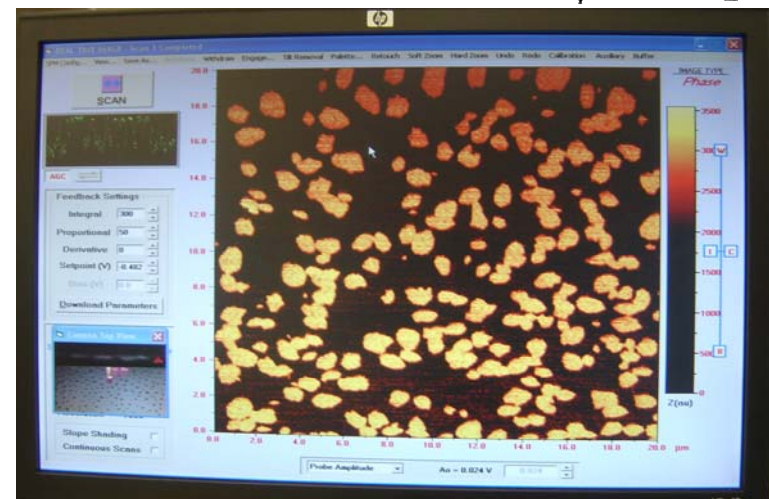
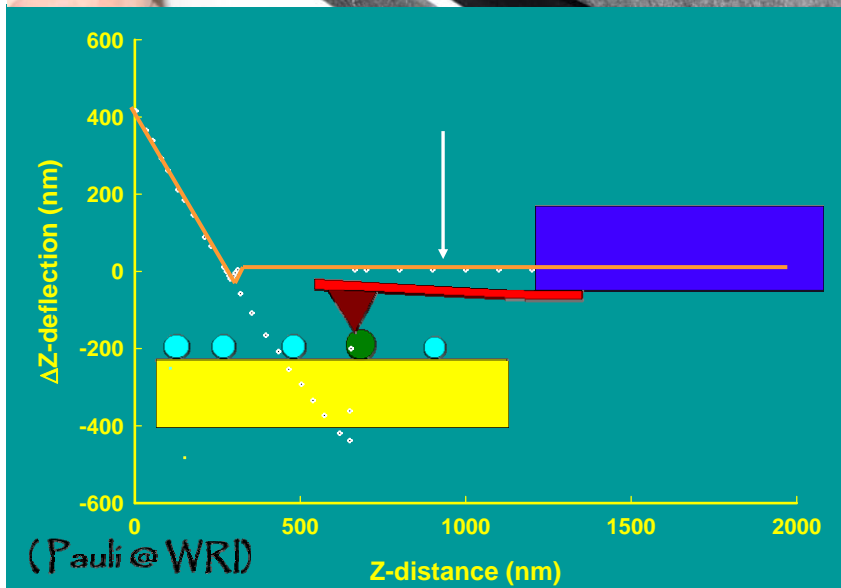

Bitumen under the AFM

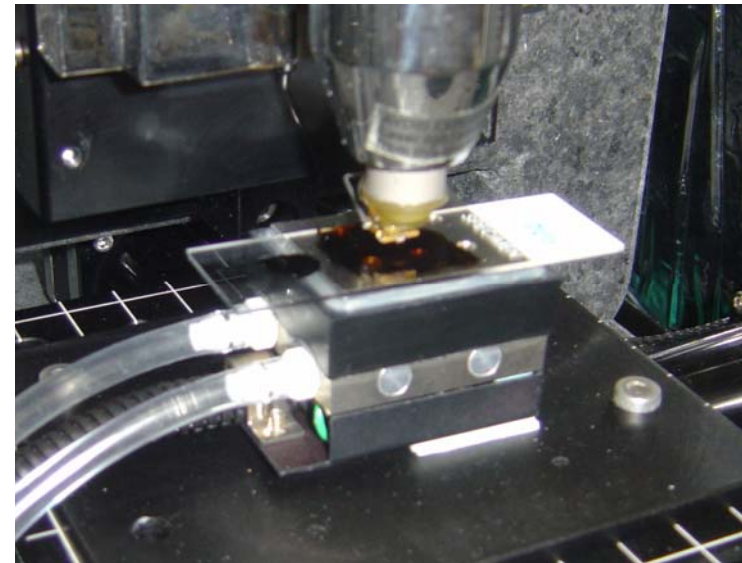

(phase image)

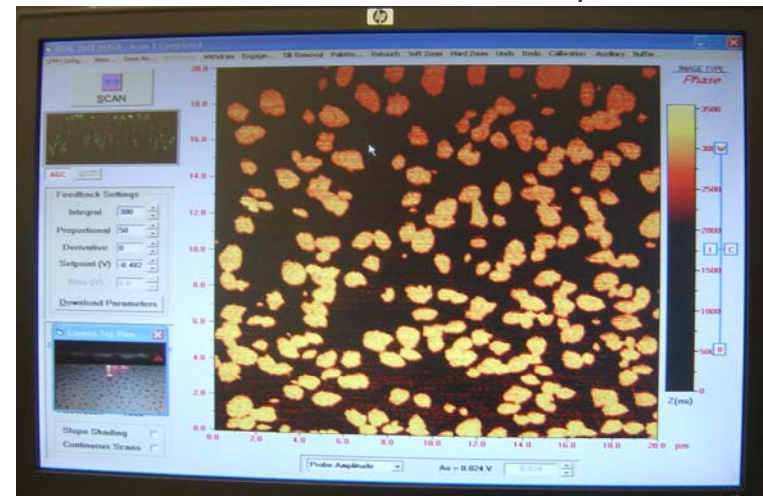
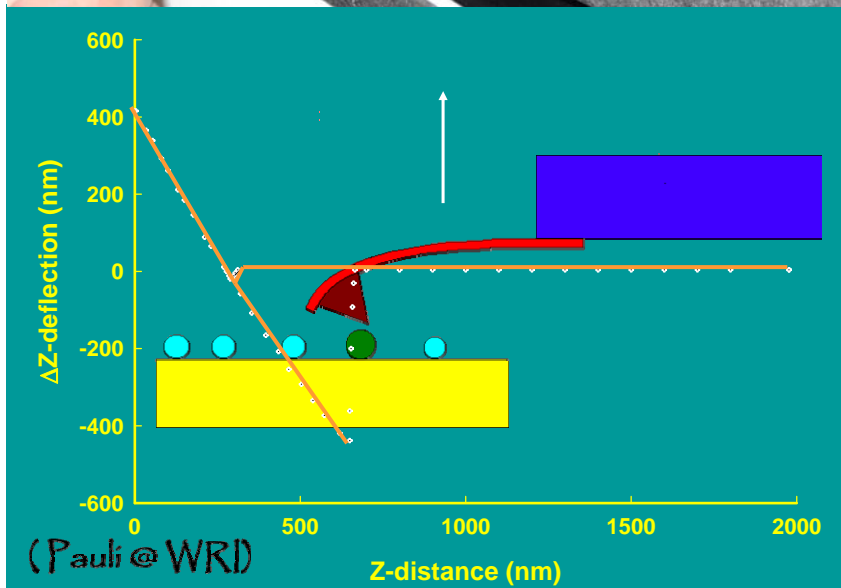

Bitumen under the AFM

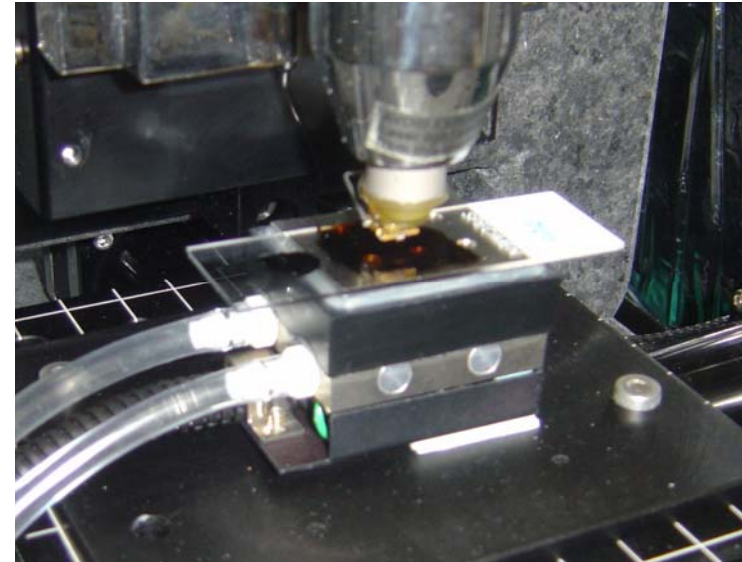

(phase image)

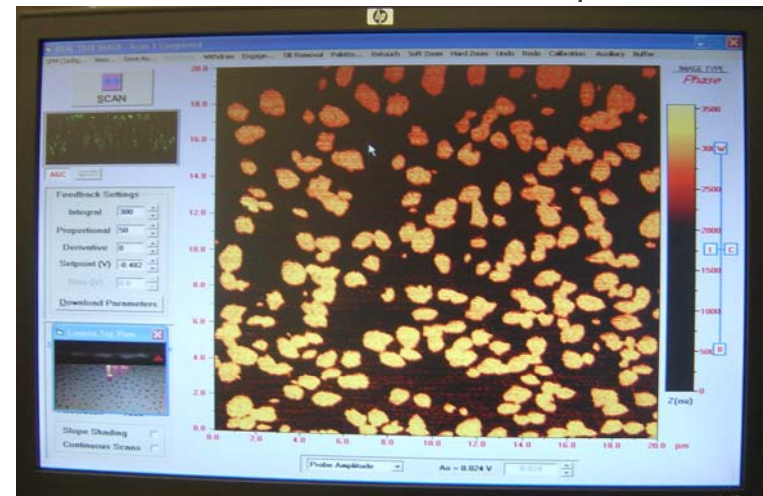
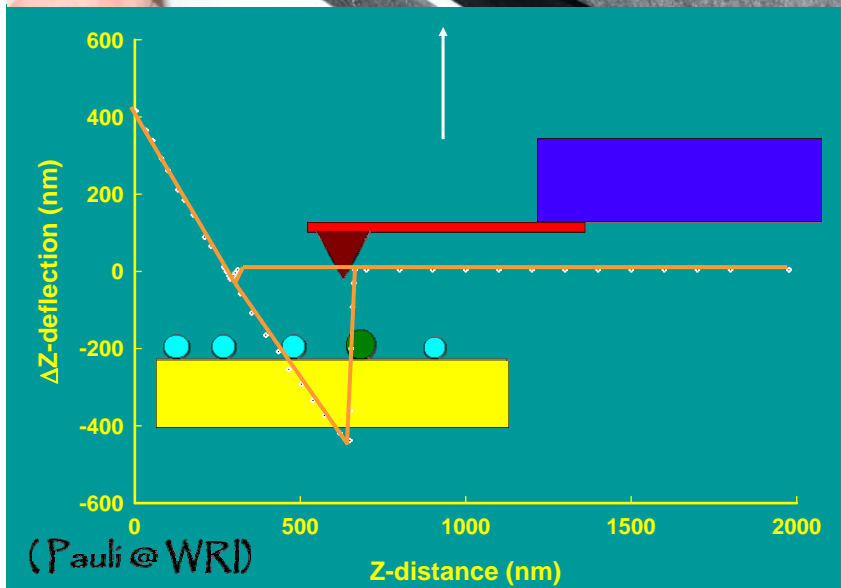

Bitumen under the AFM

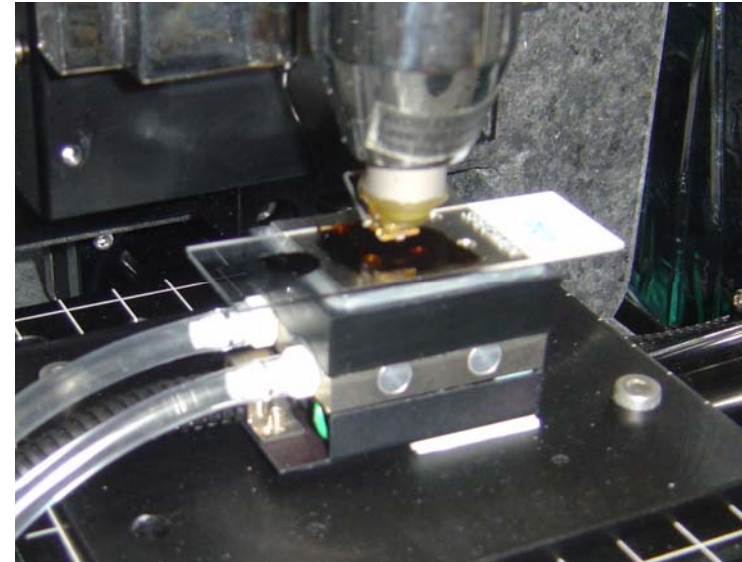

(phase image)

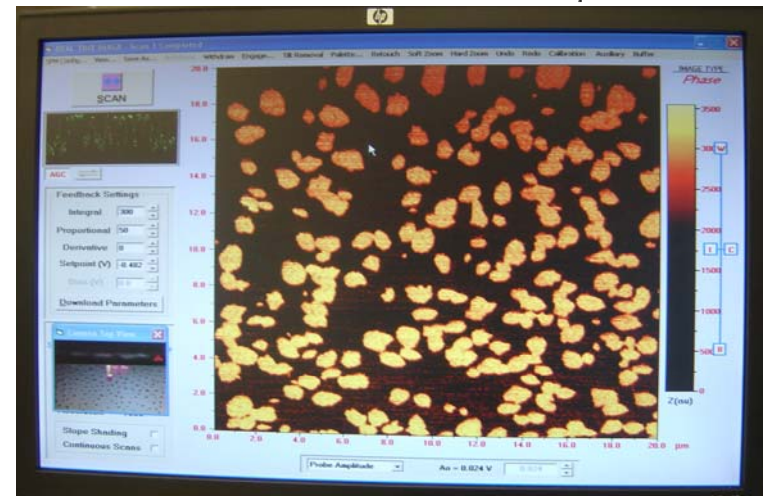
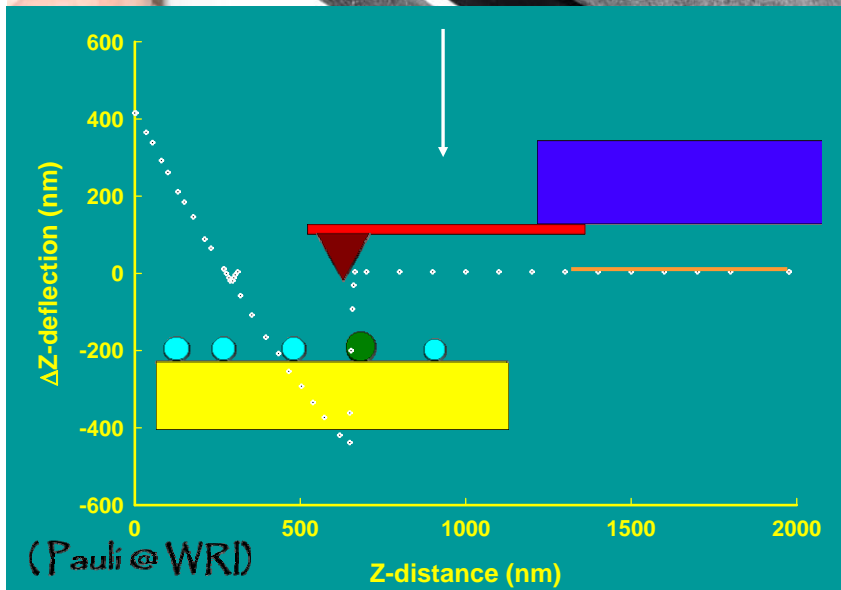

Bitumen under the AFM

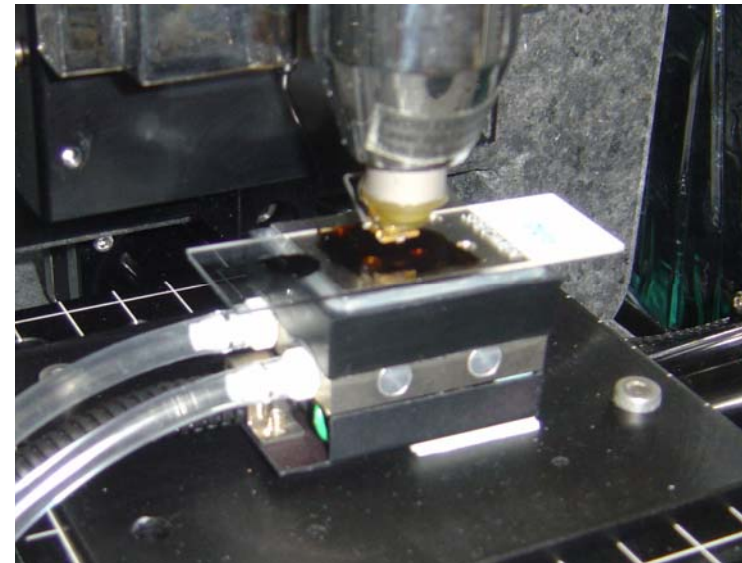

(phase image)

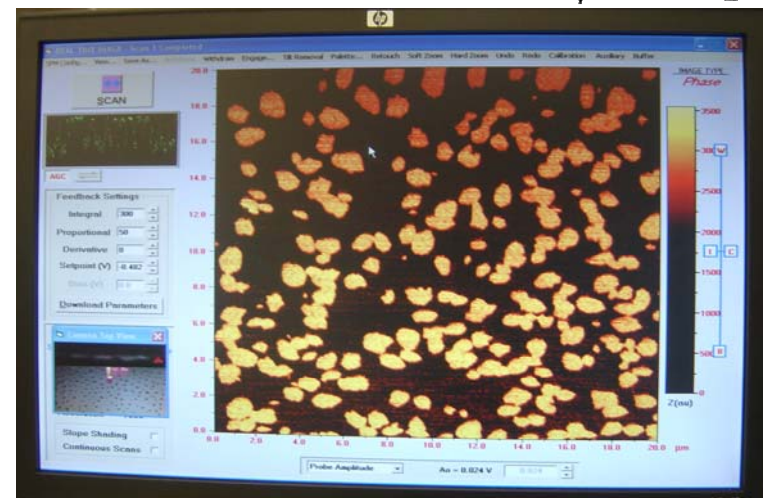
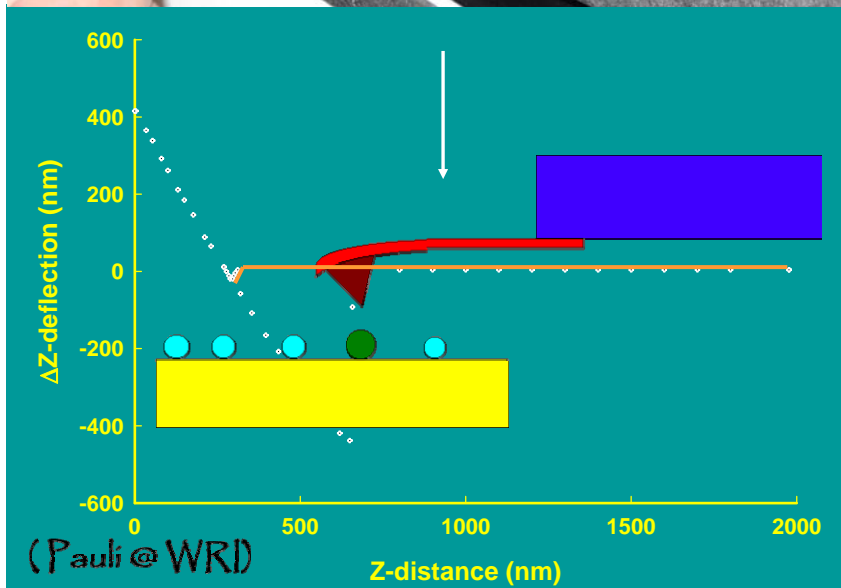

Bitumen under the AFM

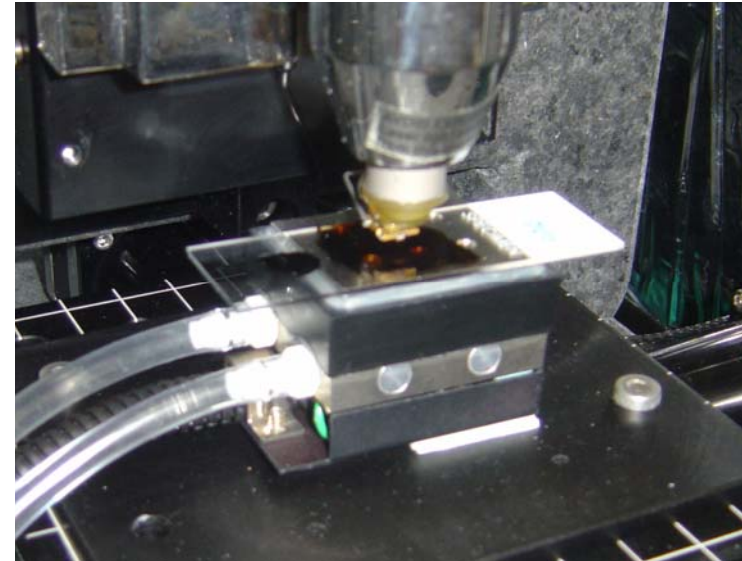

(phase image)

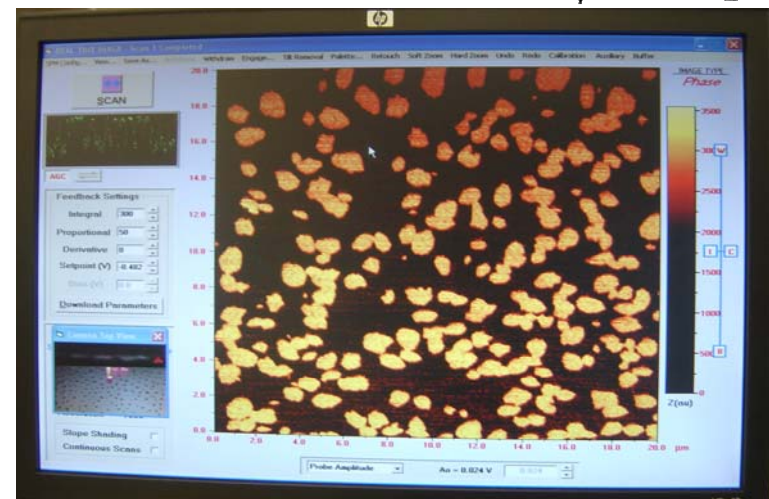
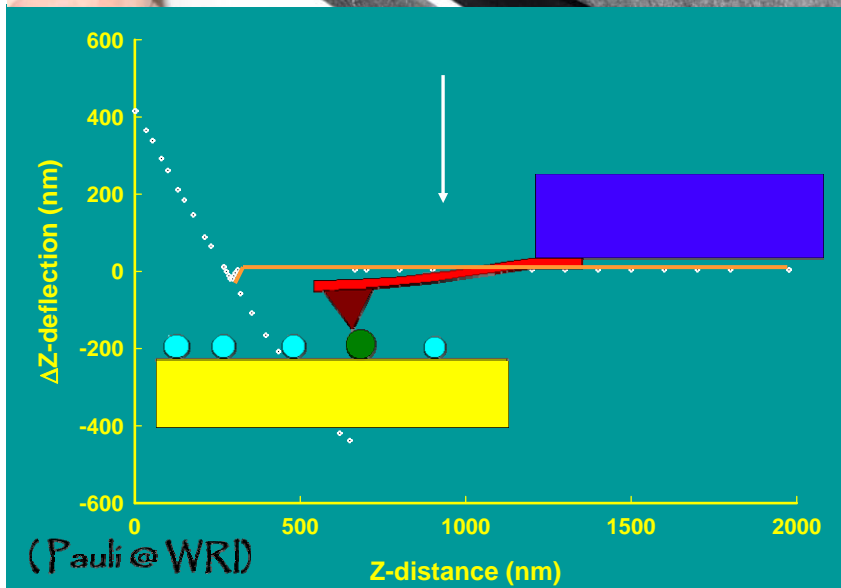

Bitumen under the AFM

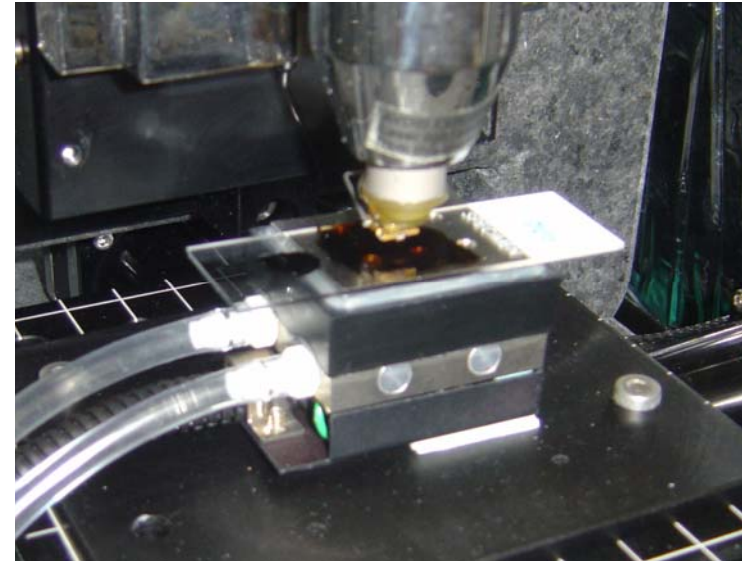

(phase image)

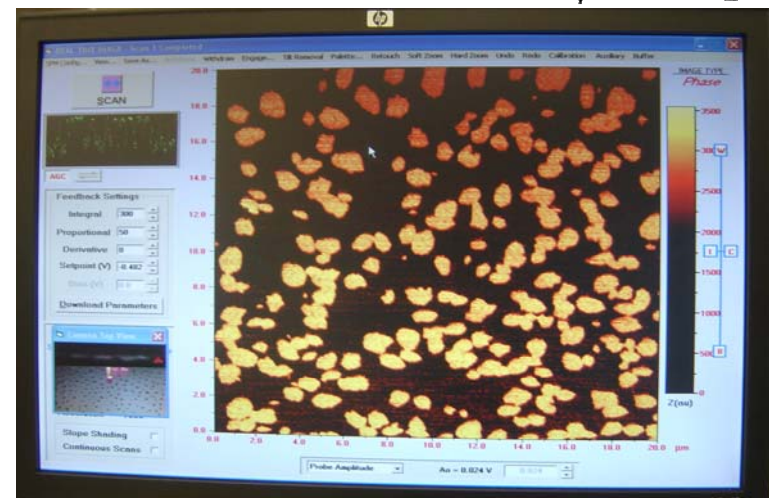
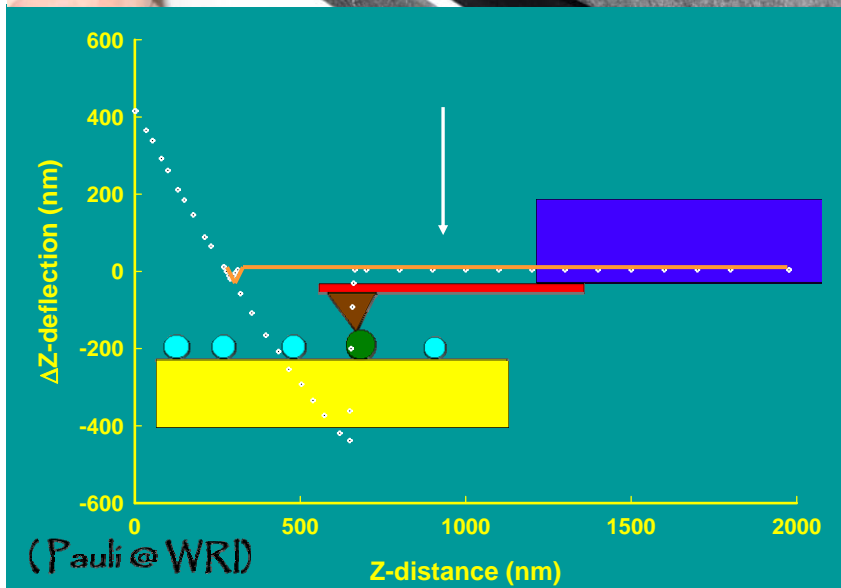

Bitumen under the AFM

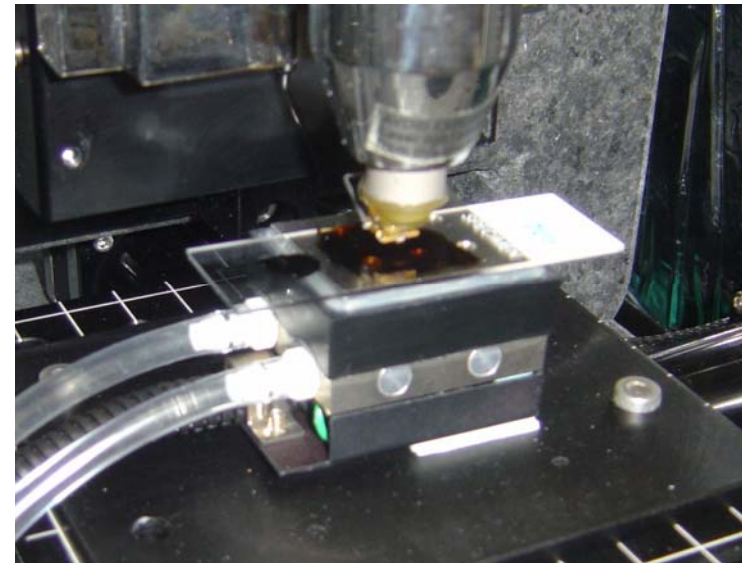

(phase image)

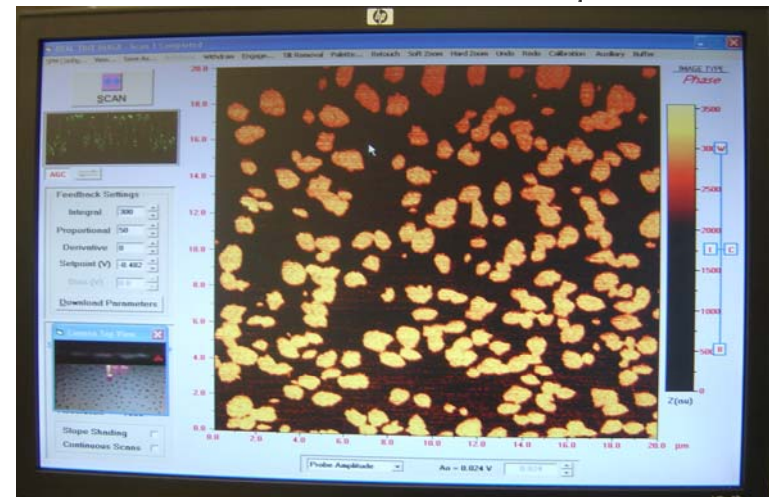
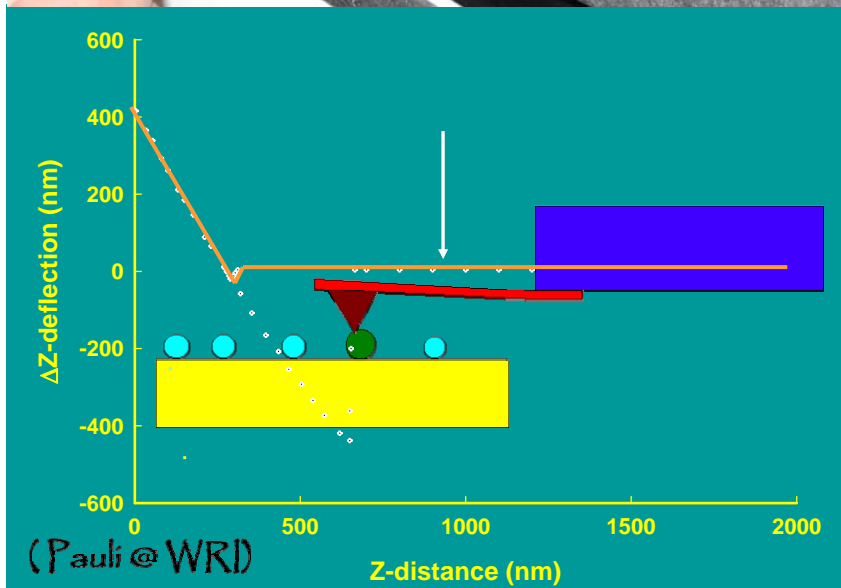

Bitumen under the AFM

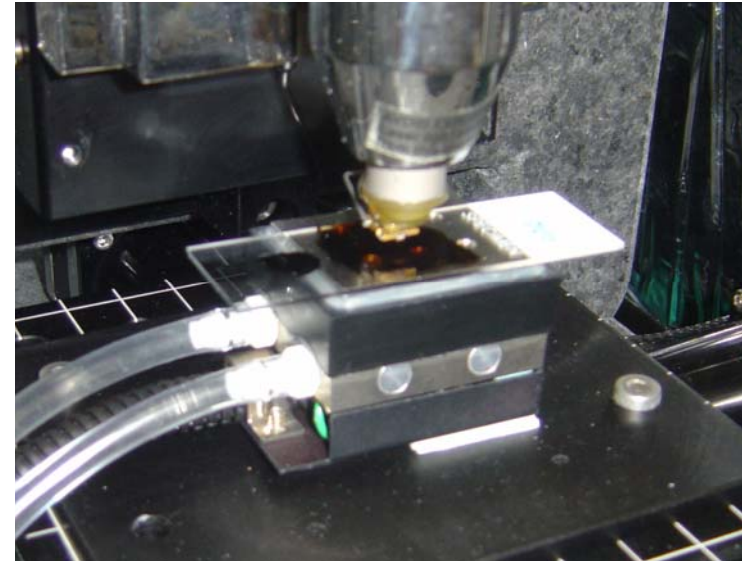

(phase image)

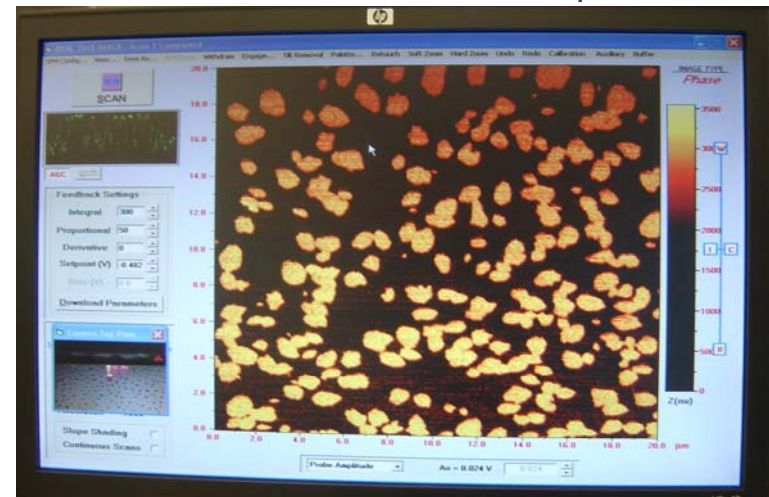
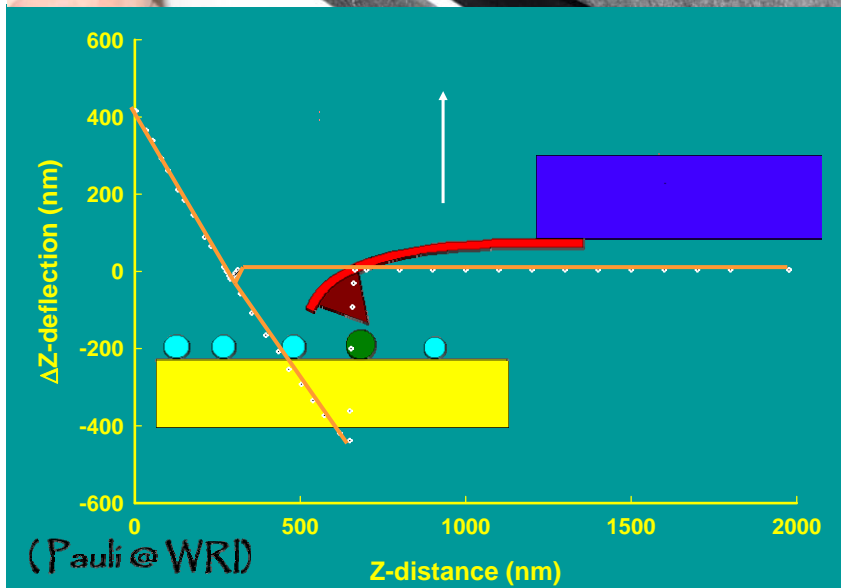

Bitumen under the AFM

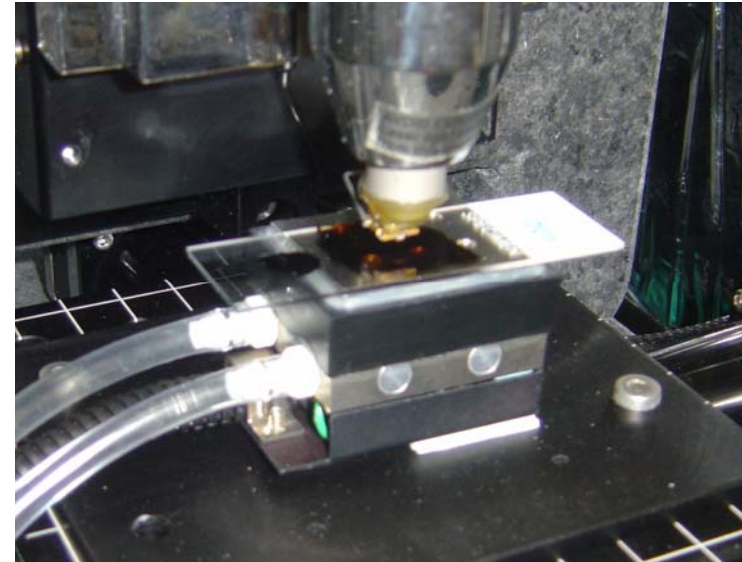

(phase image)

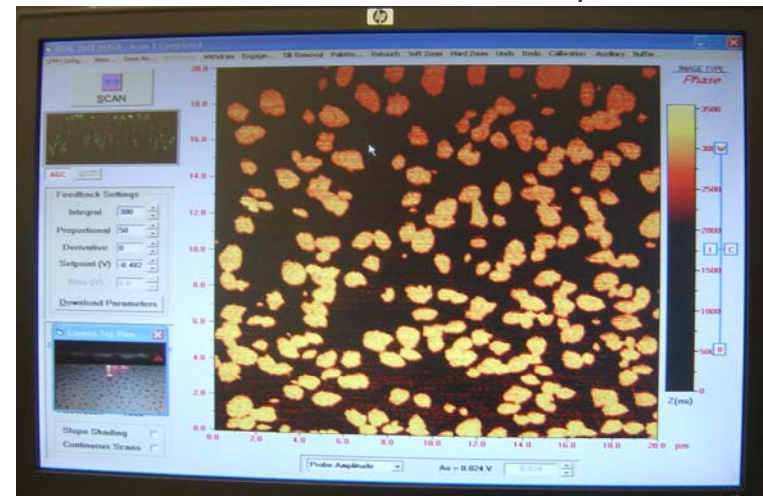
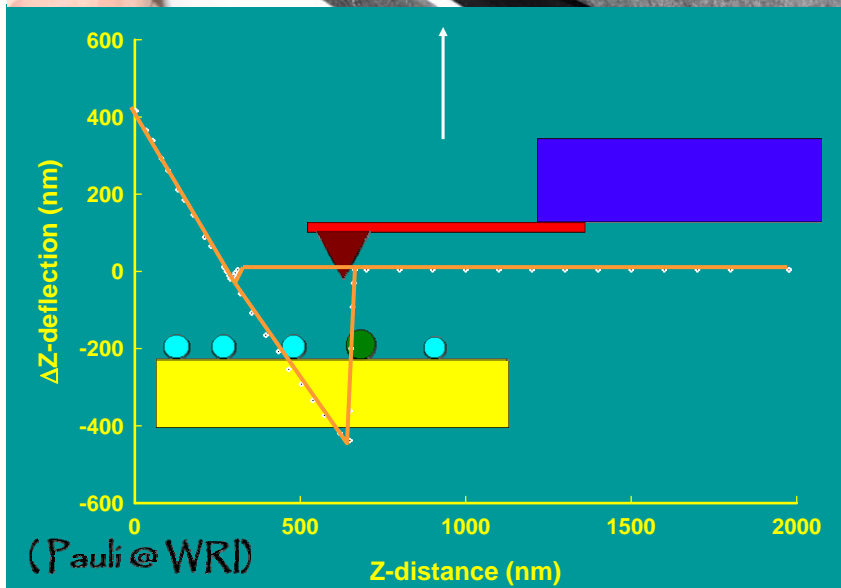

Bitumen under the AFM

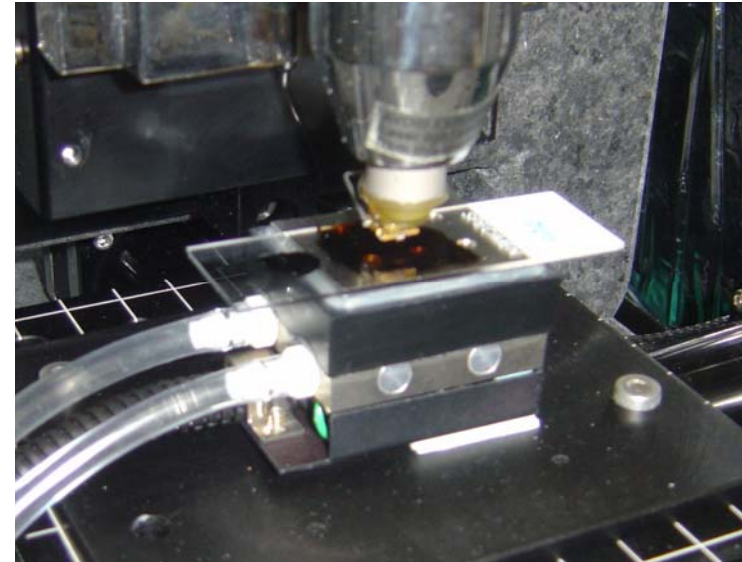

(phase image)

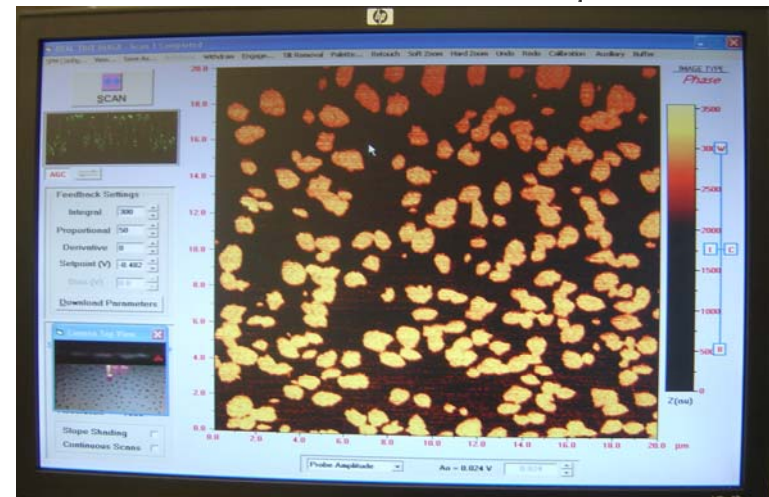
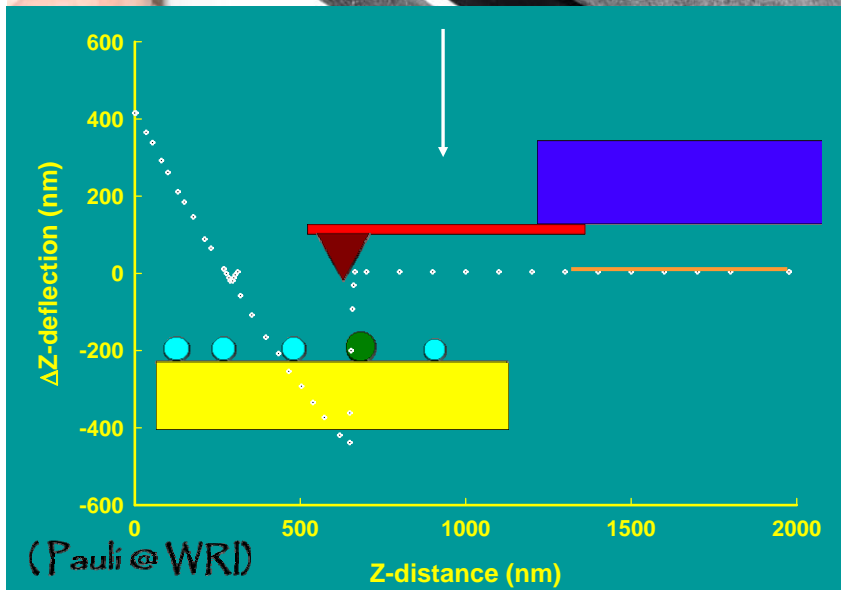

Bitumen under the AFM

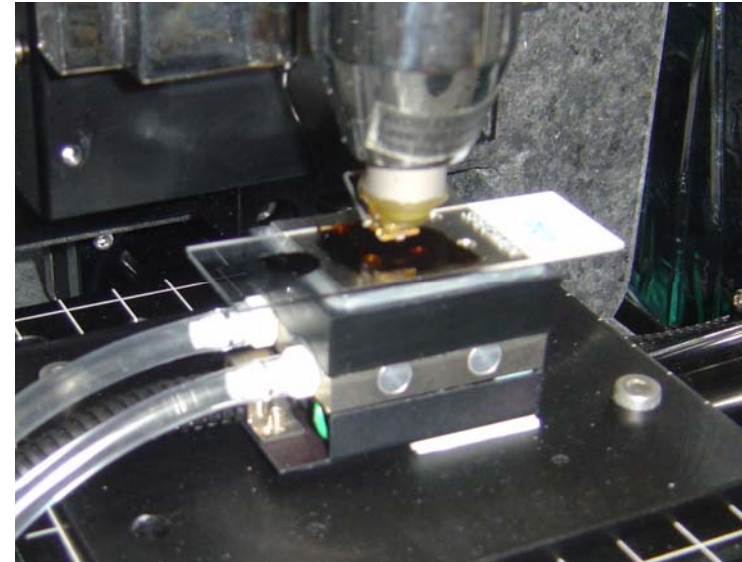

(phase image)

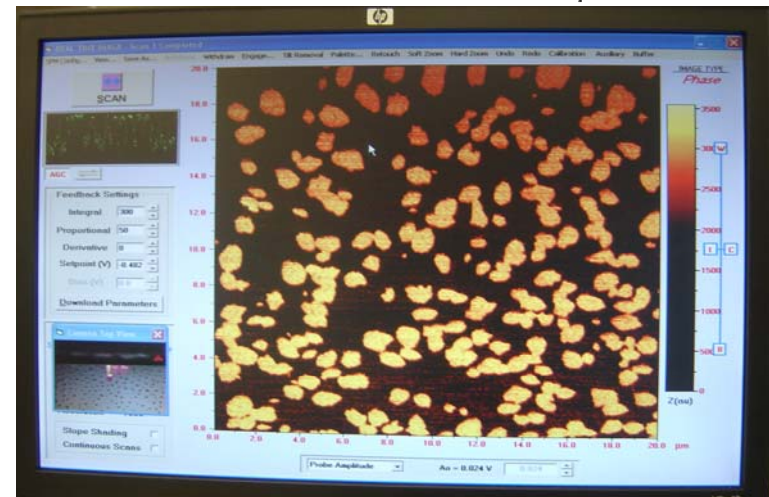
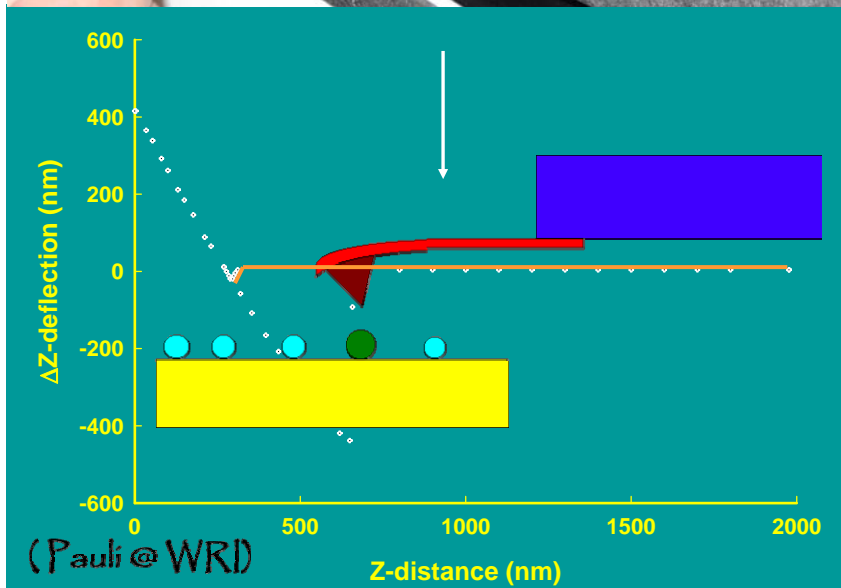

Bitumen under the AFM

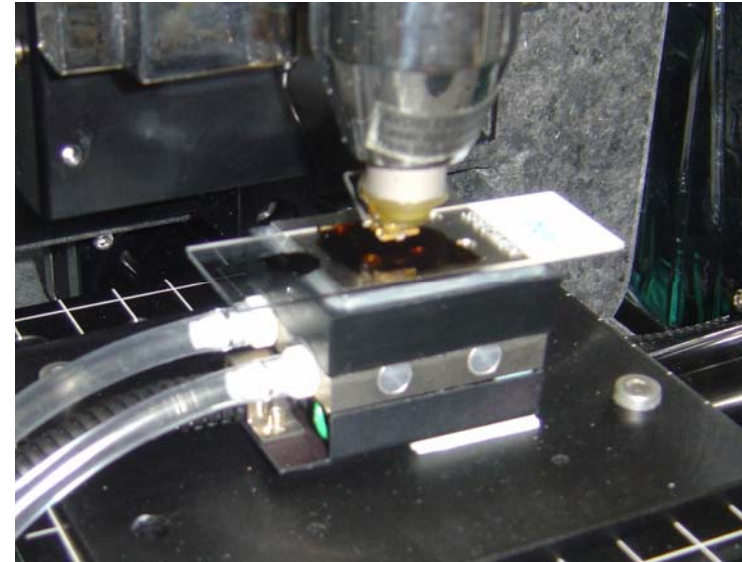

(phase image)

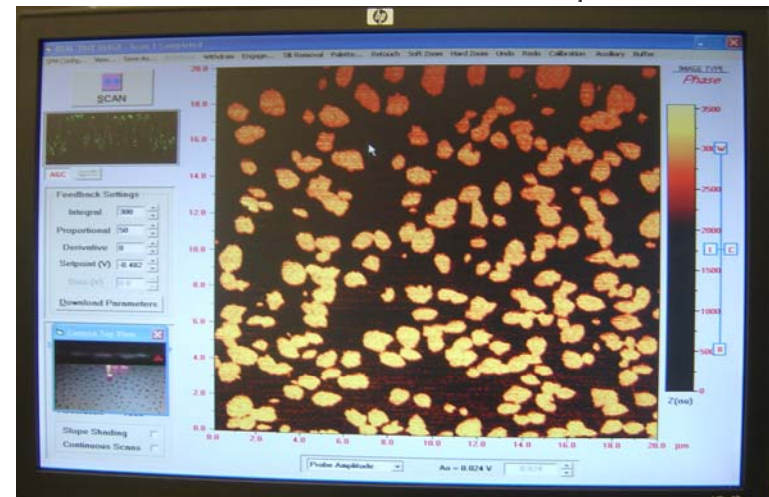
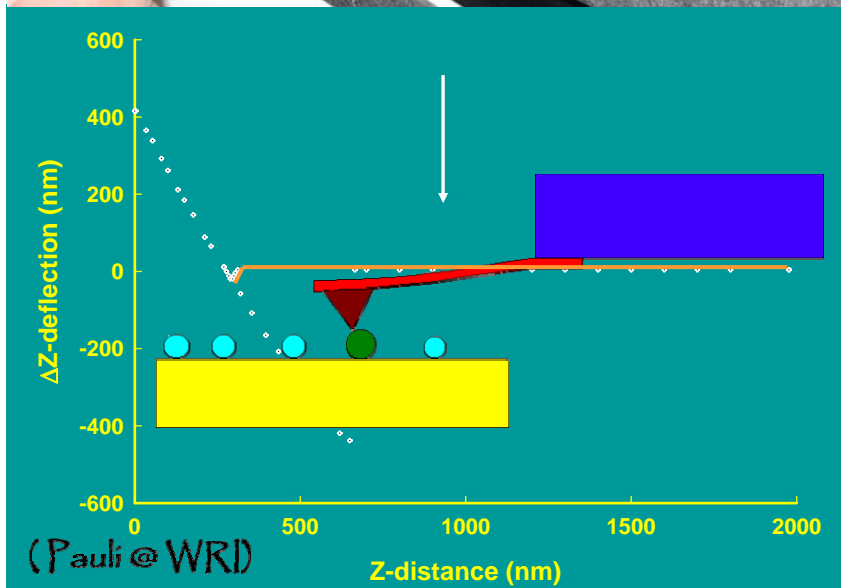

Bitumen under the AFM

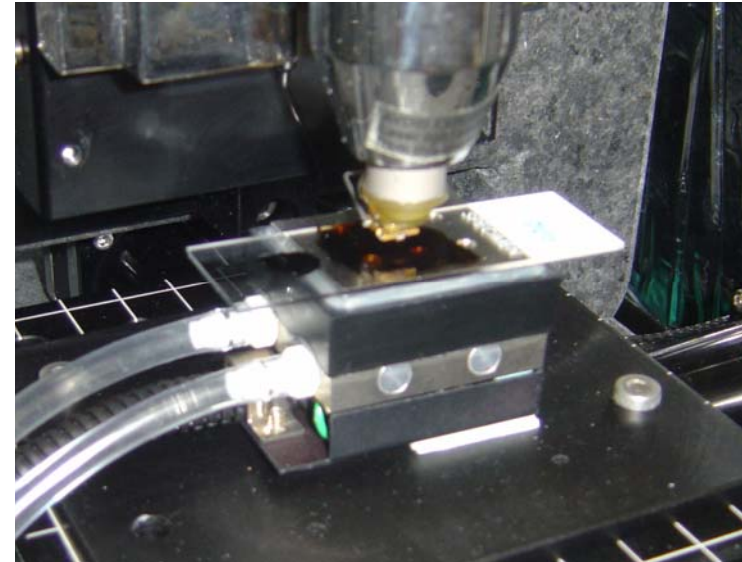

(phase image)

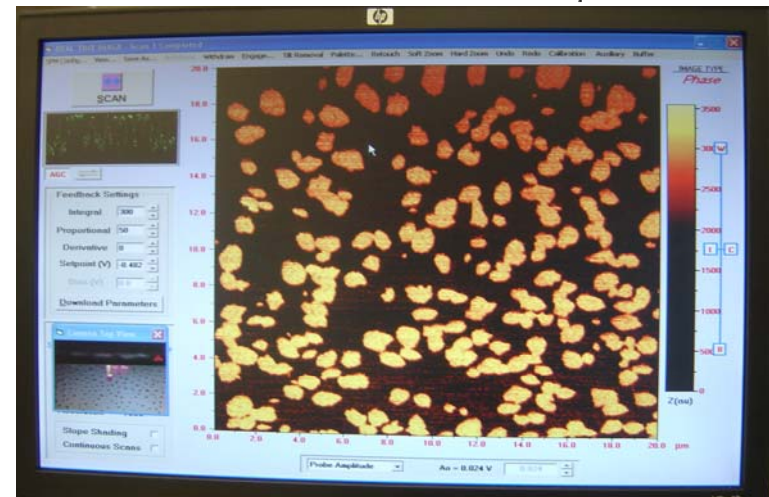
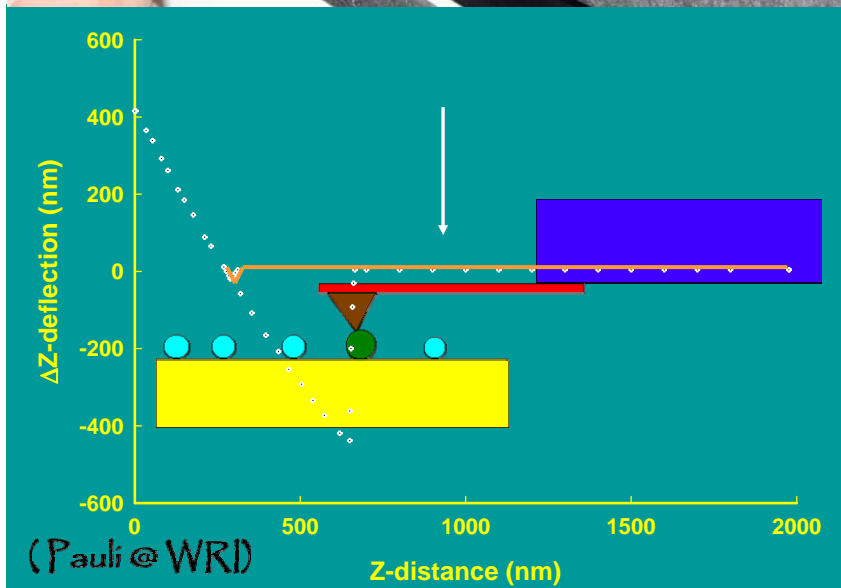

Bitumen under the AFM

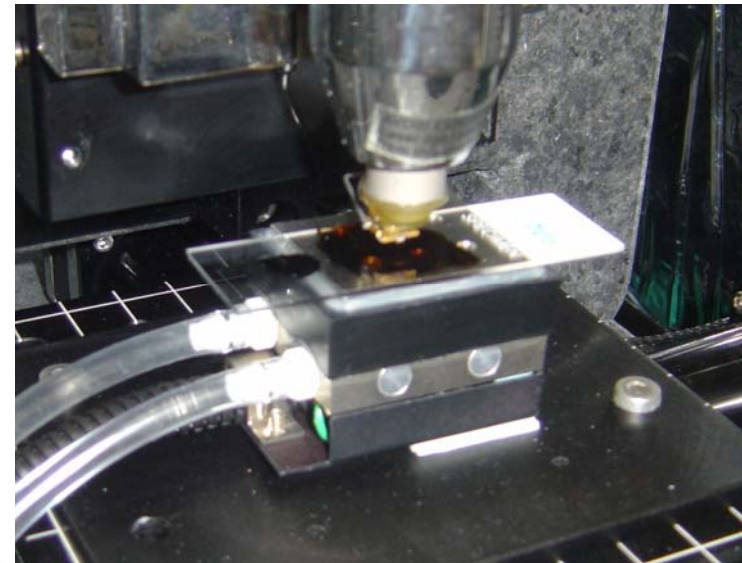

(phase image)

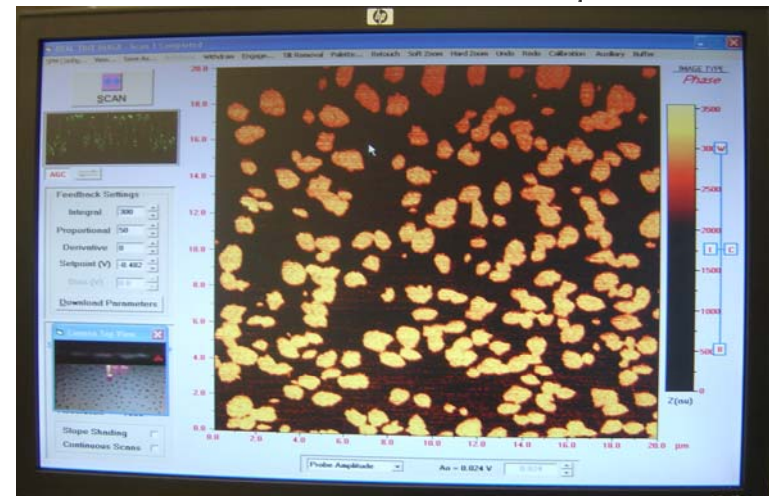
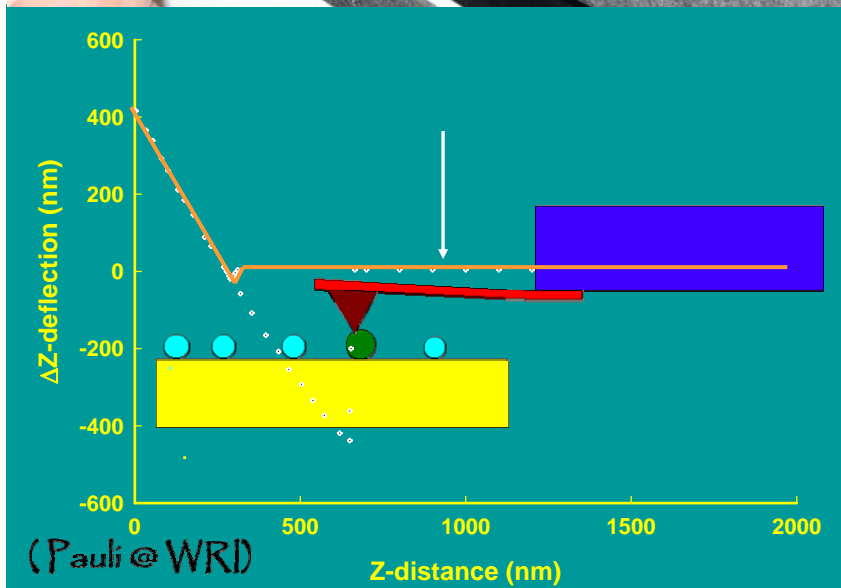

Bitumen under the AFM

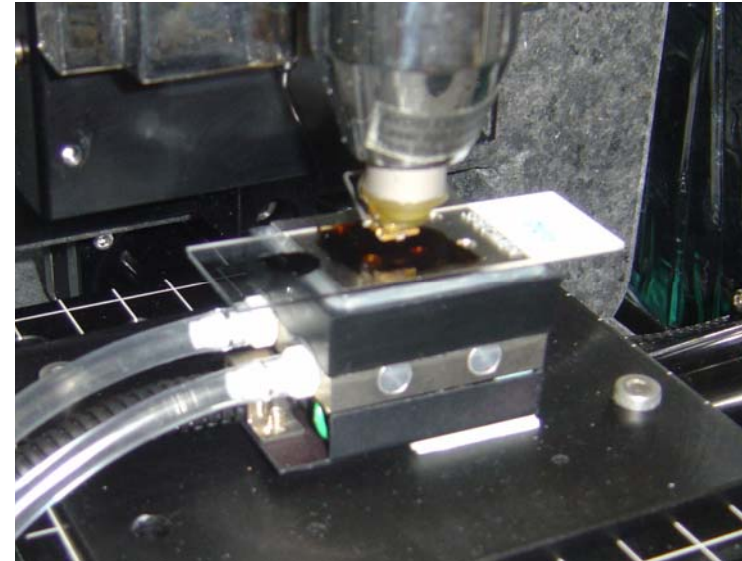

(phase image)

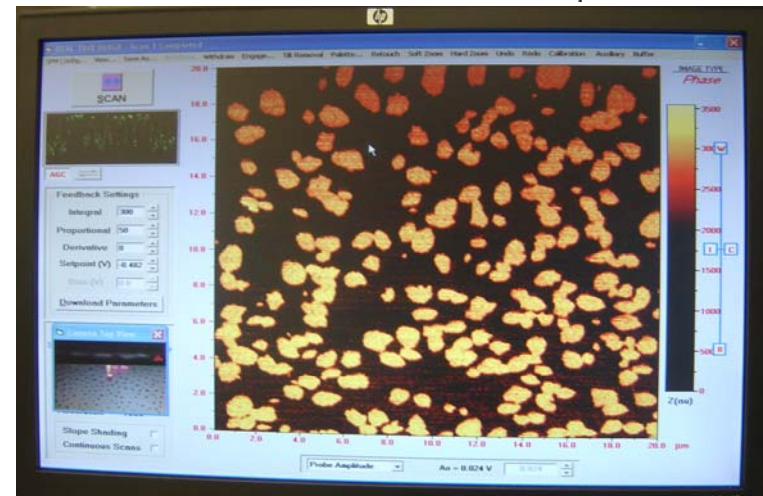
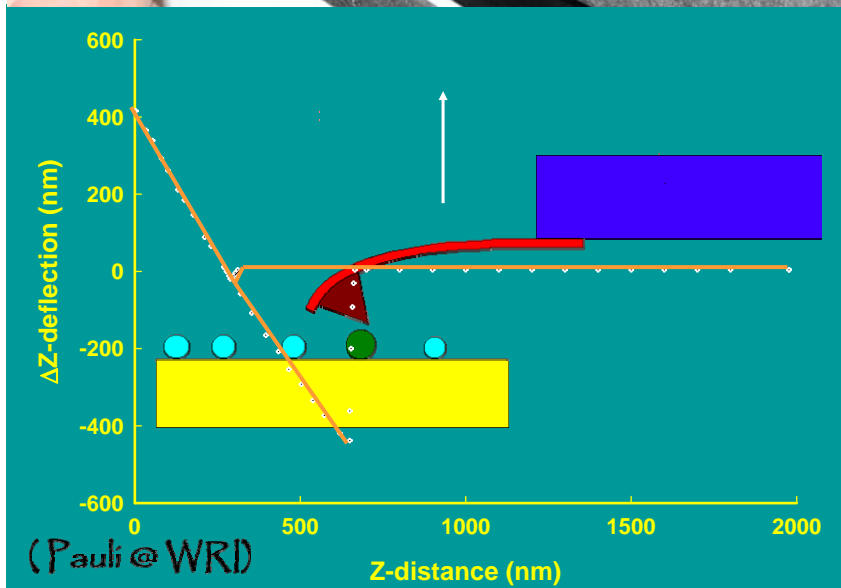

Bitumen under the AFM

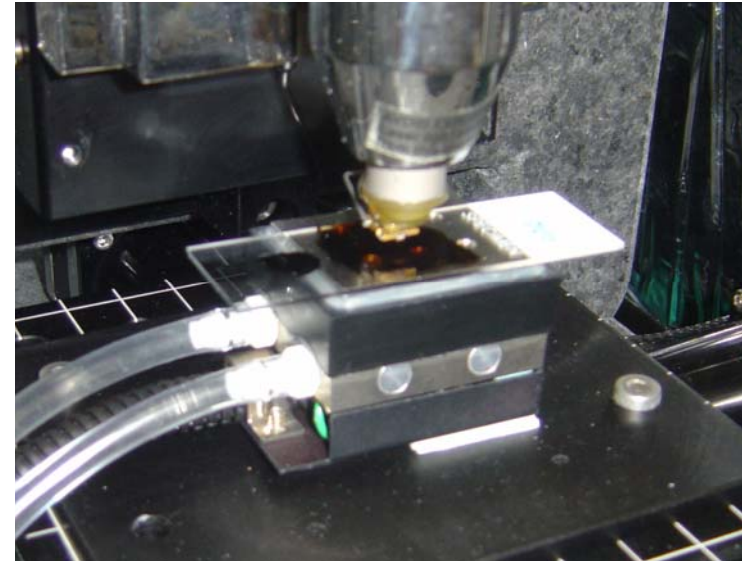

(phase image)

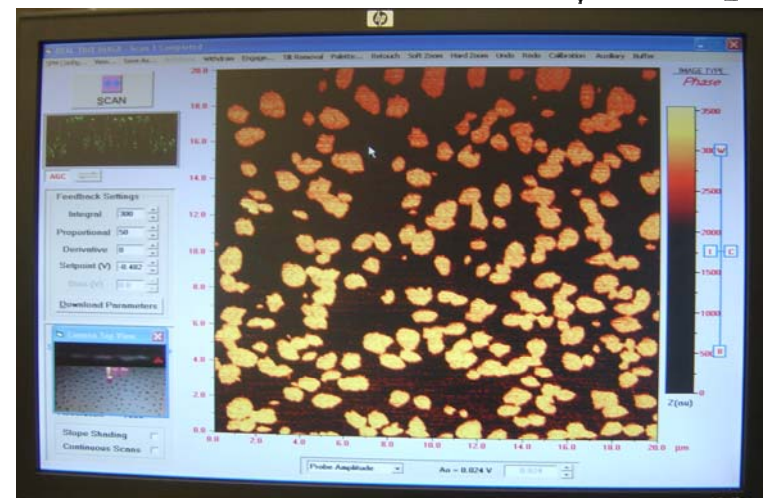
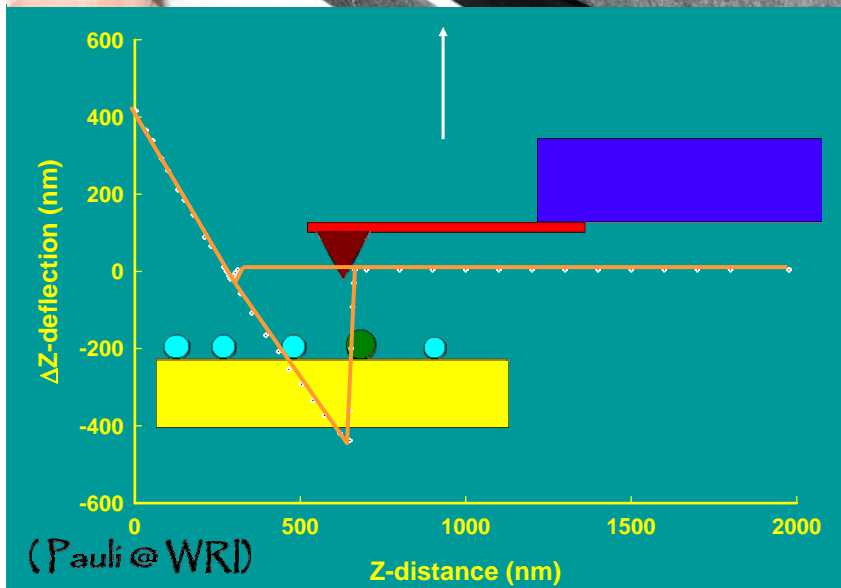

Bitumen under the AFM

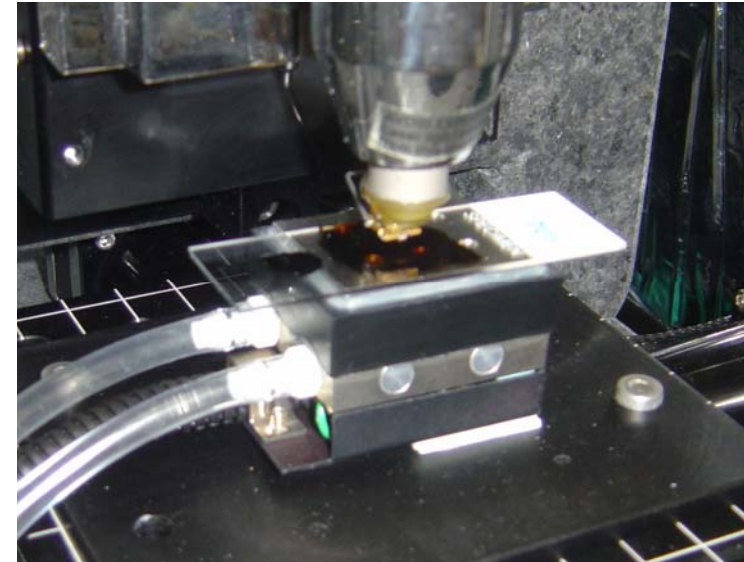

(phase image)

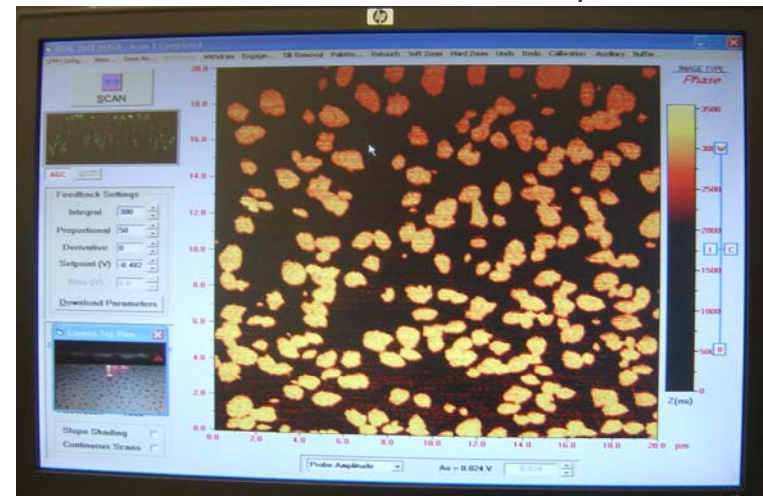
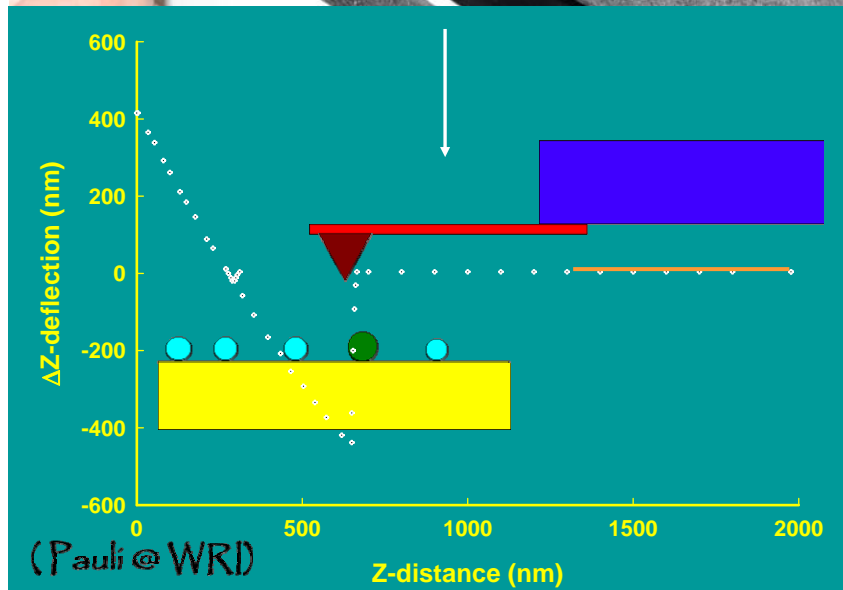

Bitumen under the AFM

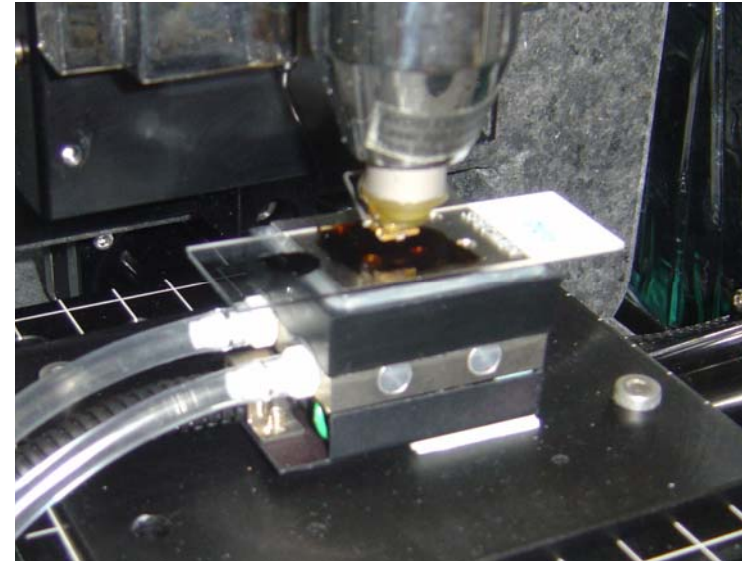

(phase image)

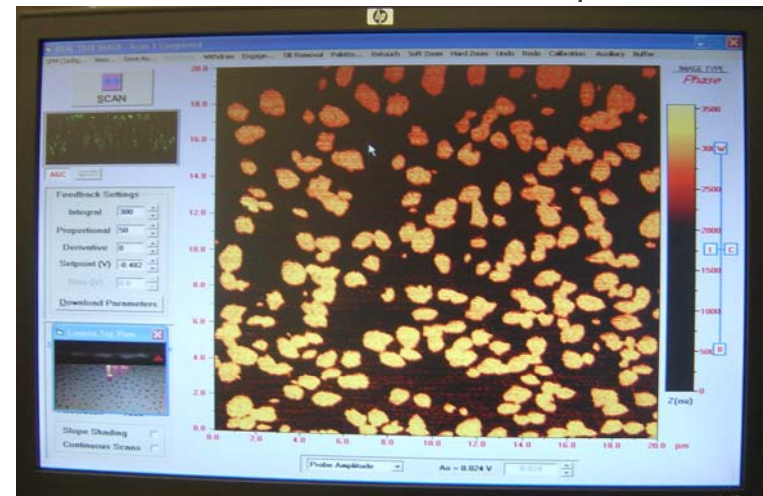
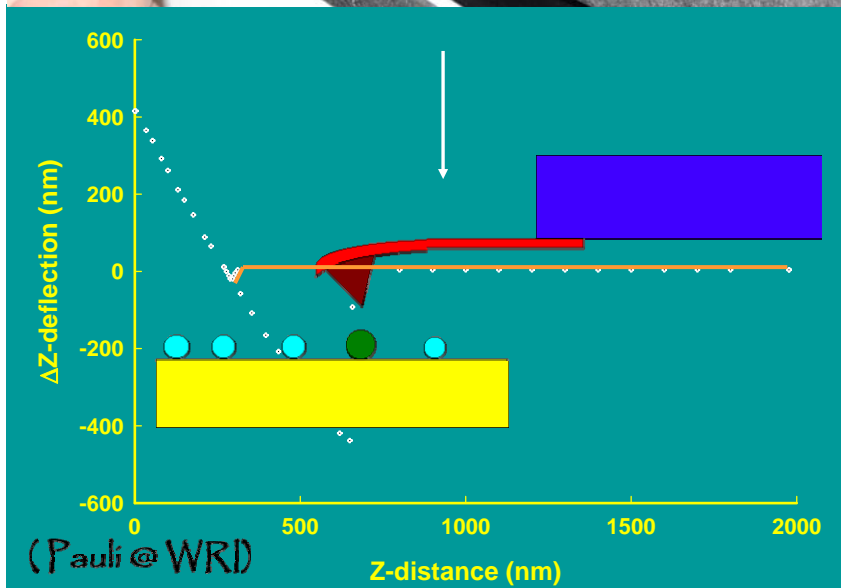

Bitumen under the AFM

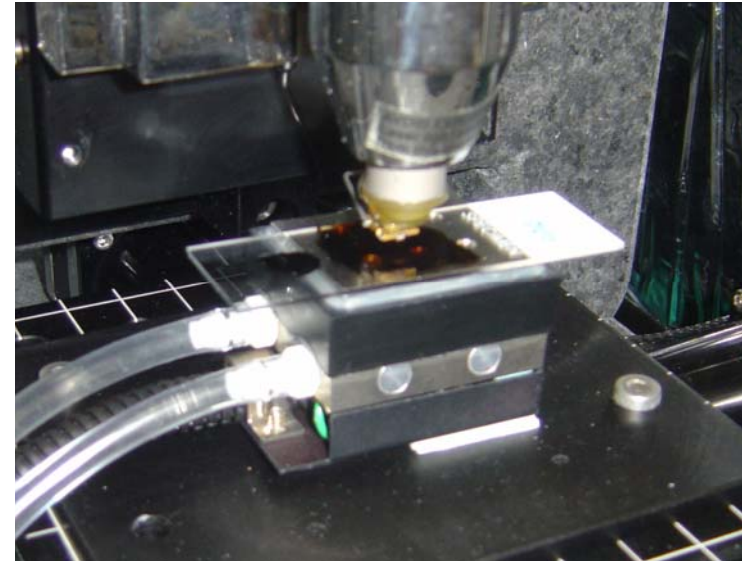

(phase image)

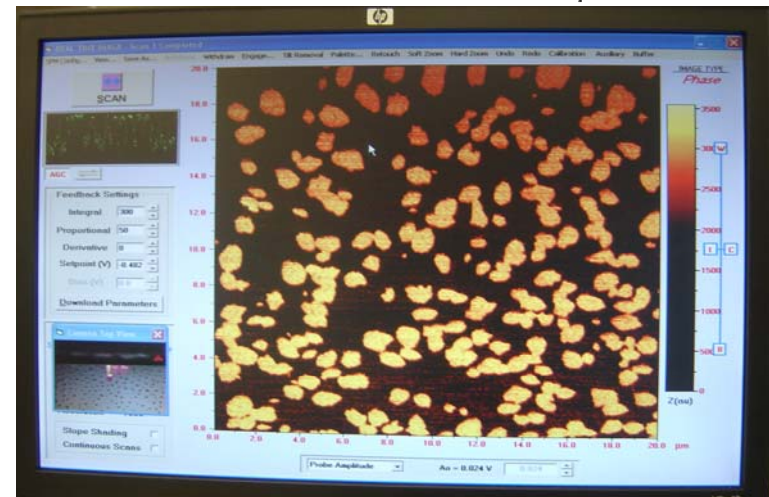
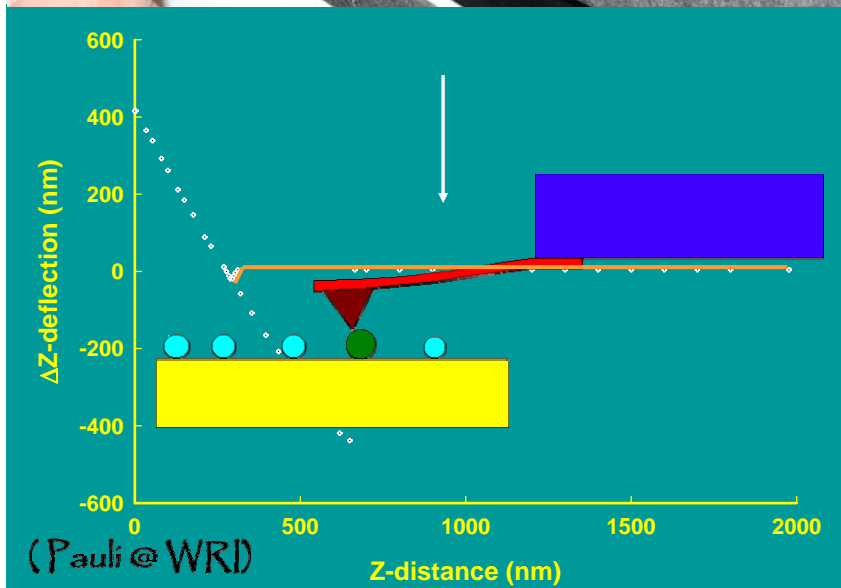

Bitumen under the AFM

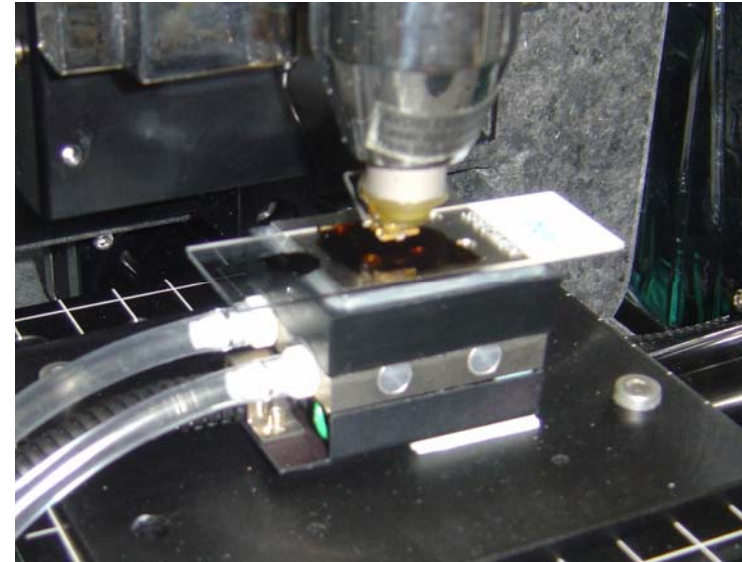

(phase image)

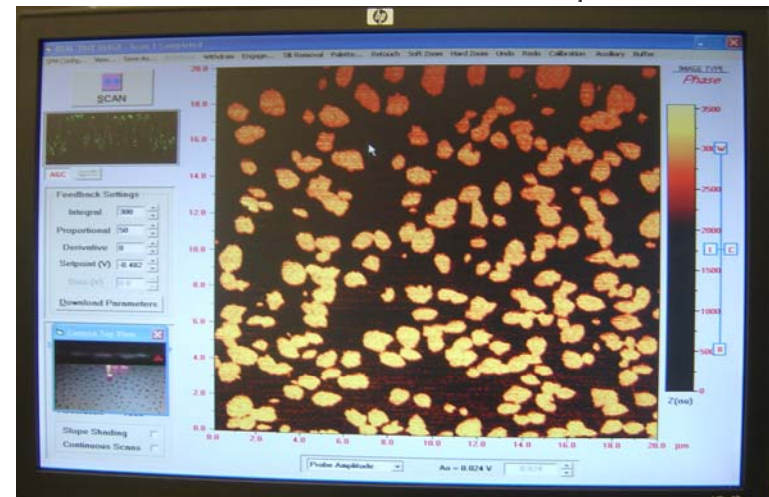
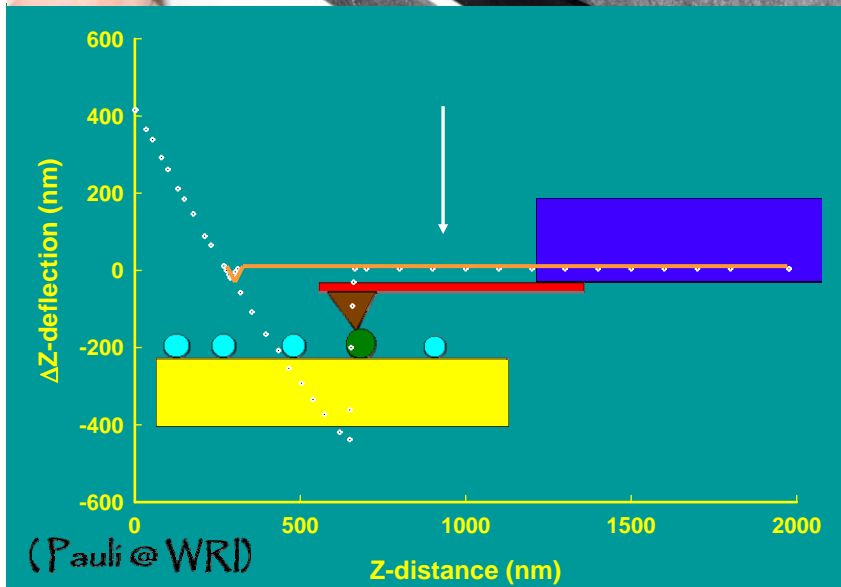

Bitumen under the AFM

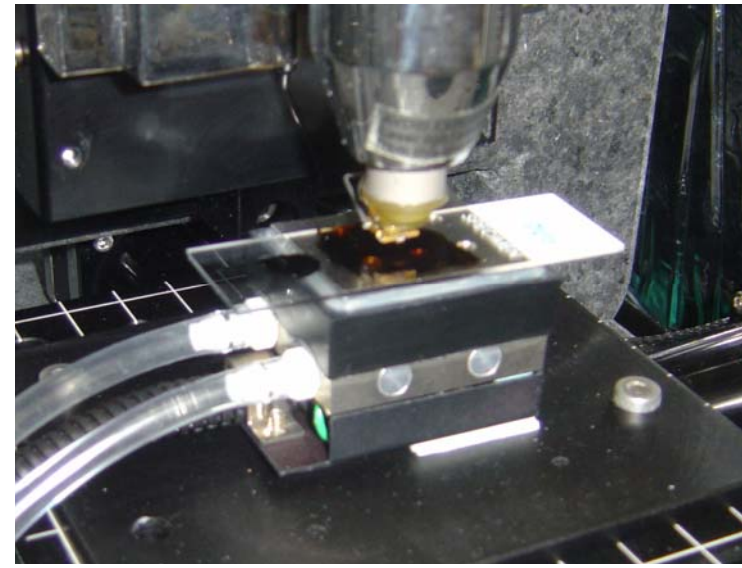

(phase image)

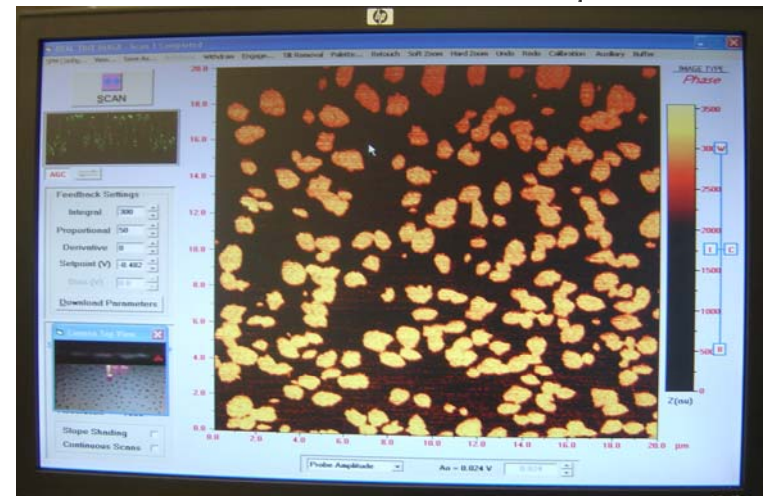
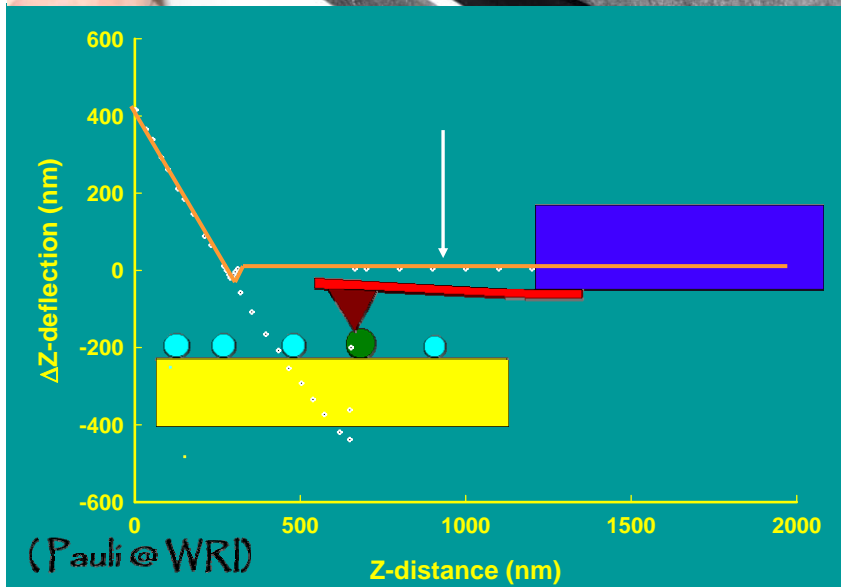

Bitumen under the AFM

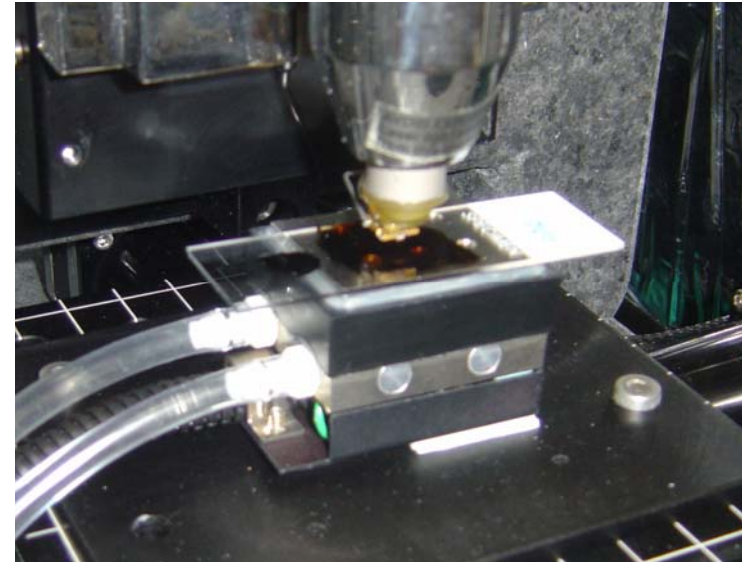

(phase image)

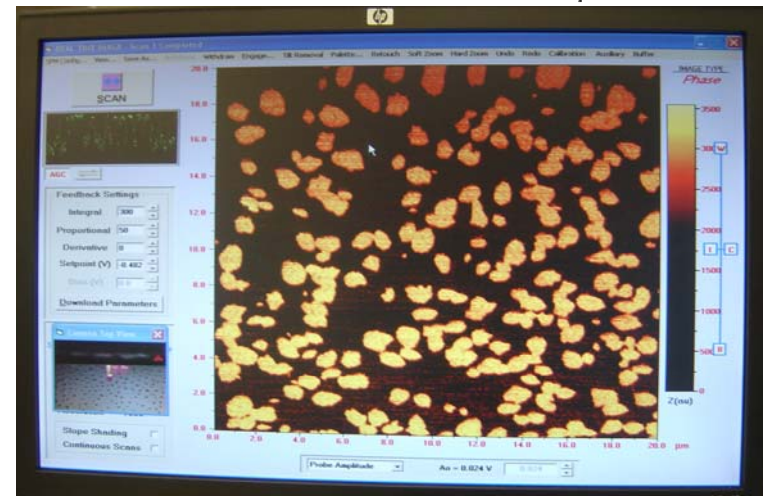
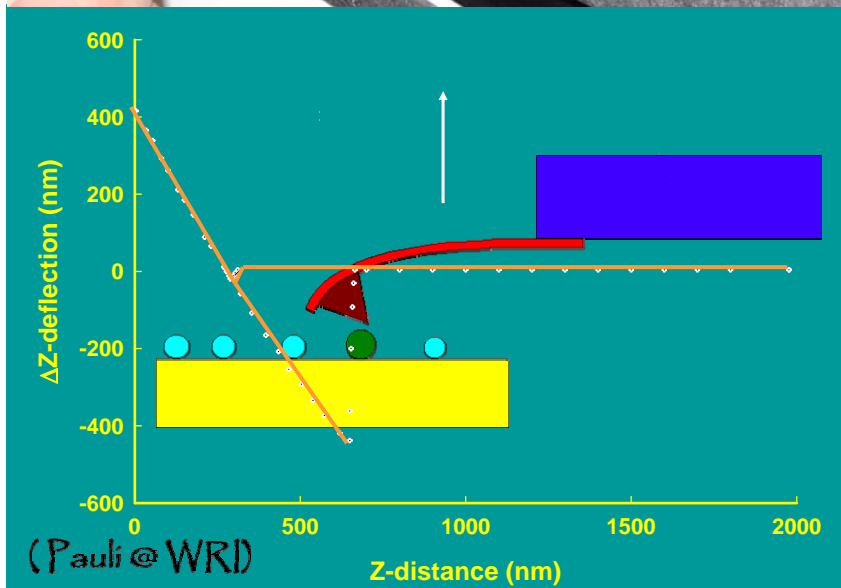

Bitumen under the AFM

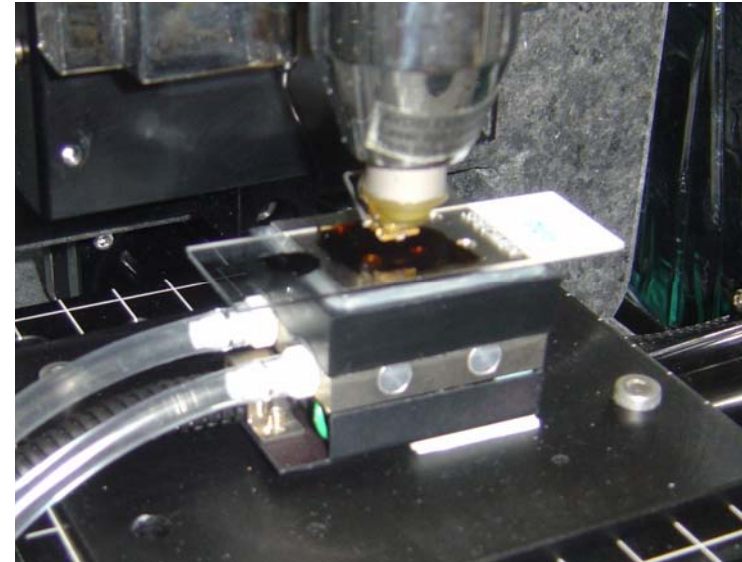

(phase image)

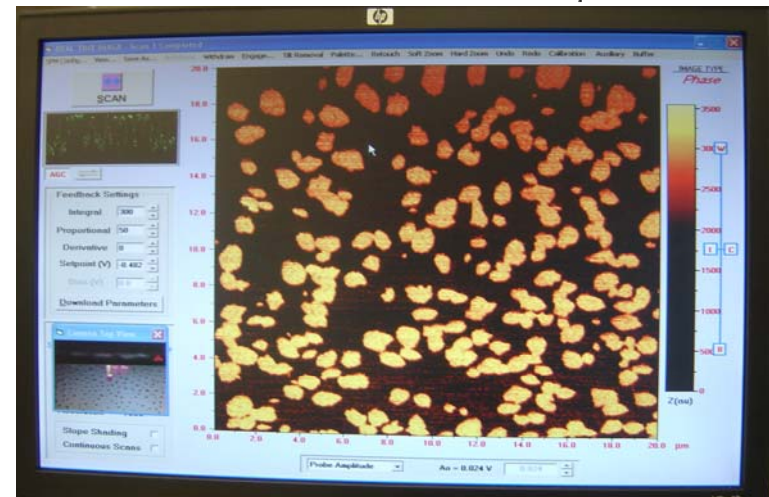
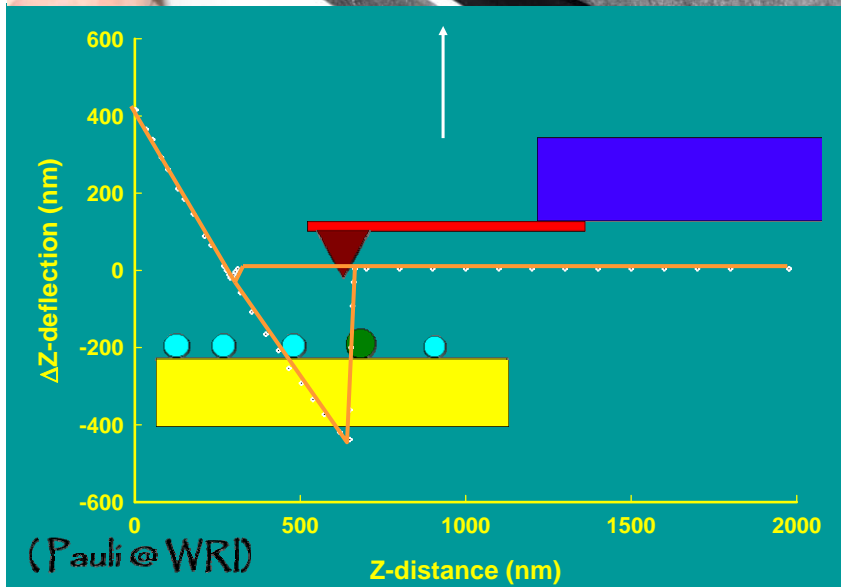

Bitumen under the AFM

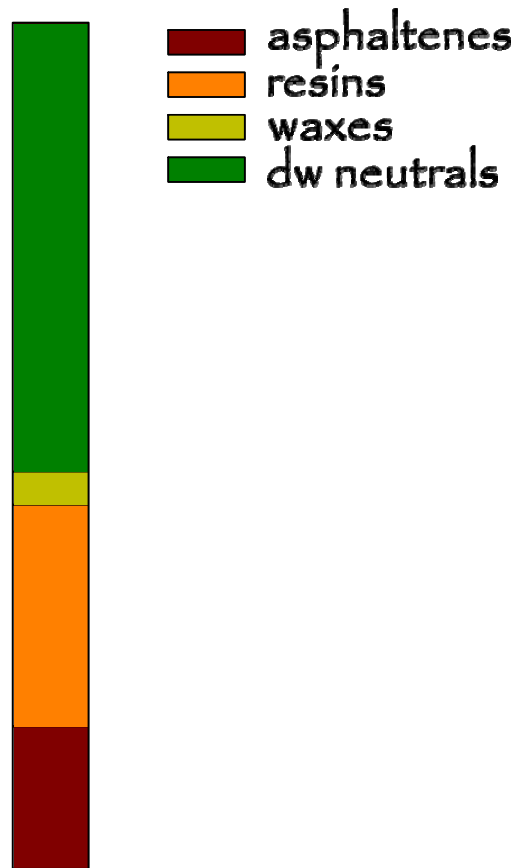

(height images)

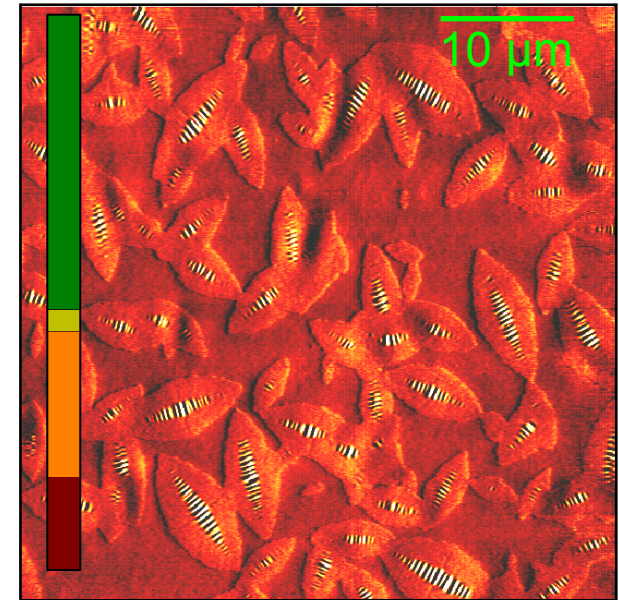

Bitumen under the AFM

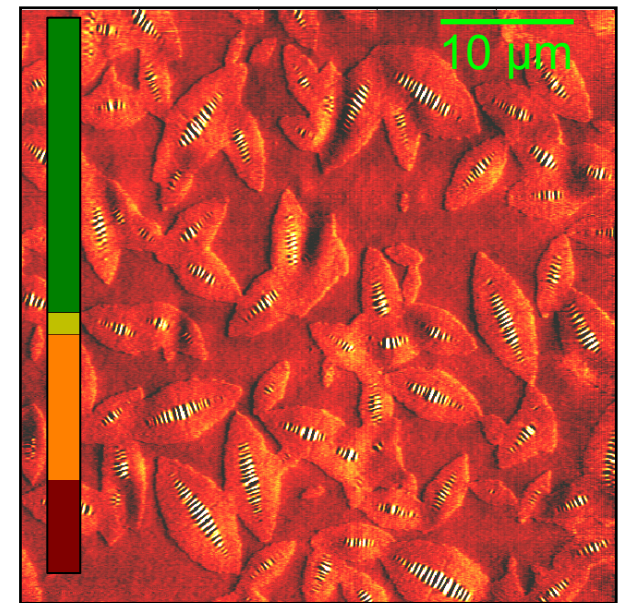
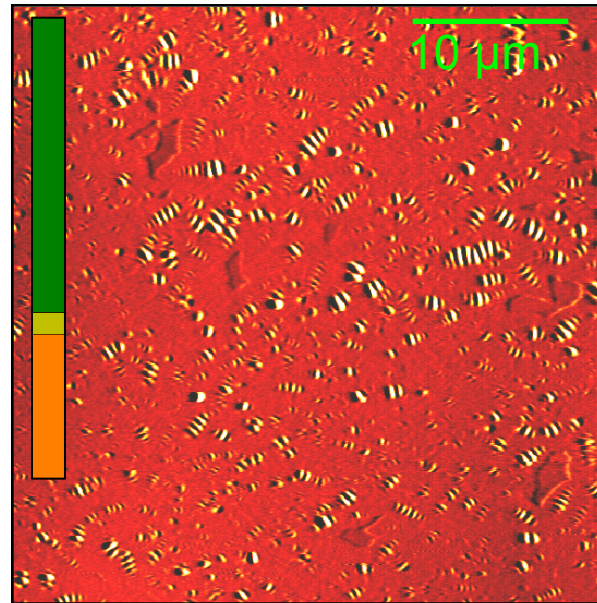
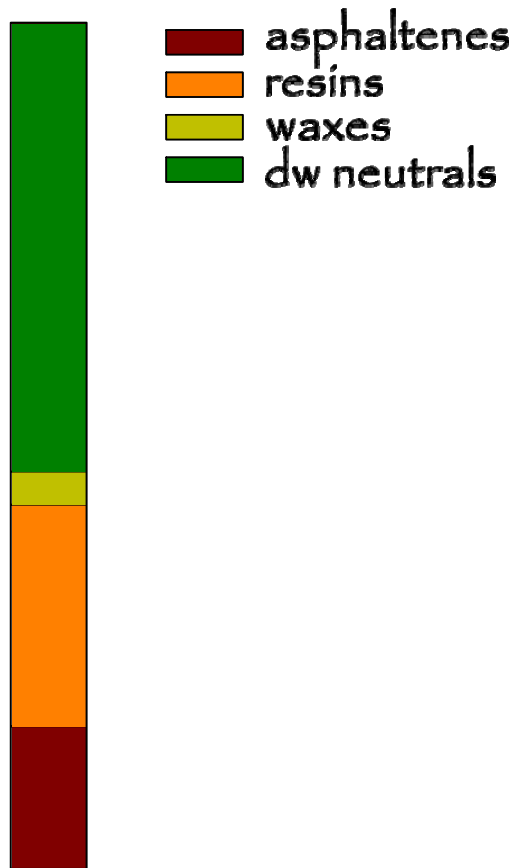

(height images)

Bitumen under the AFM

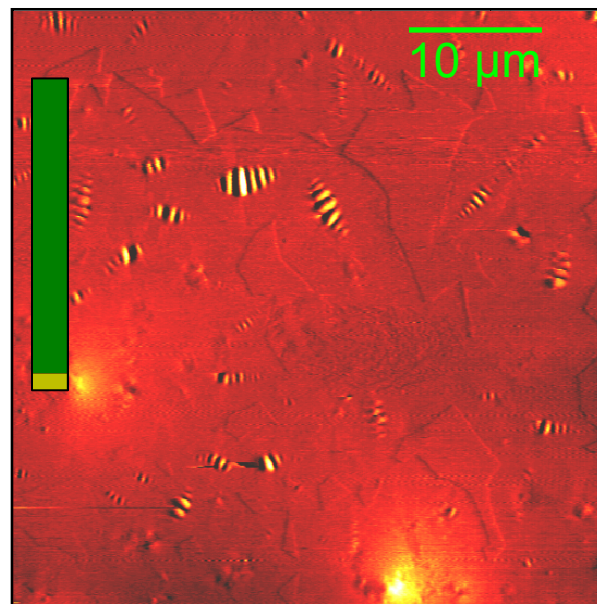
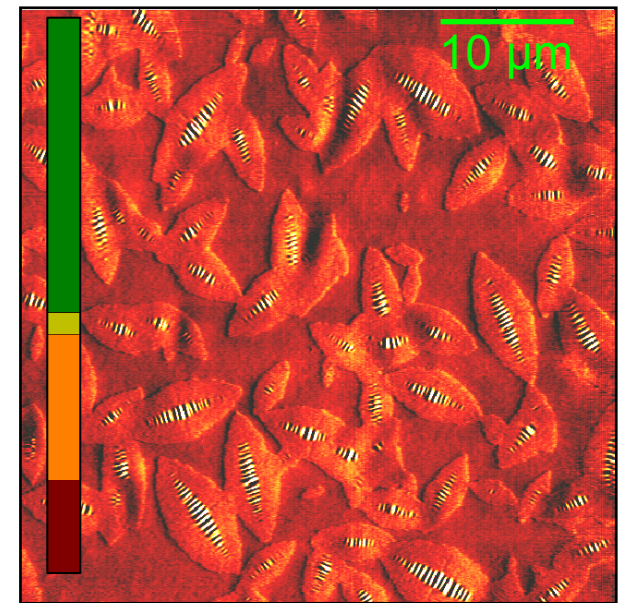
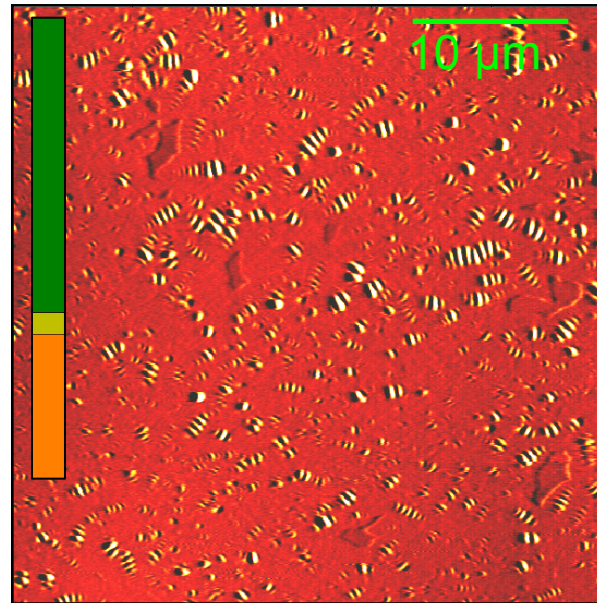
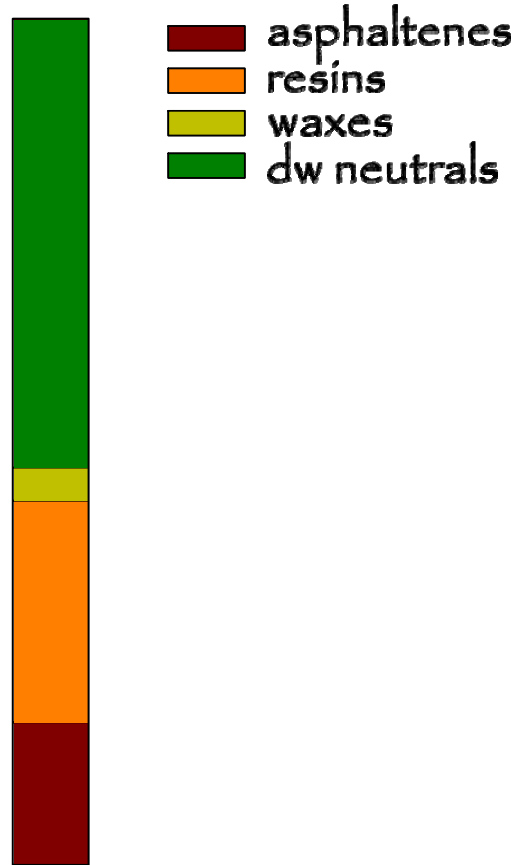

(height images)

Bitumen under the AFM

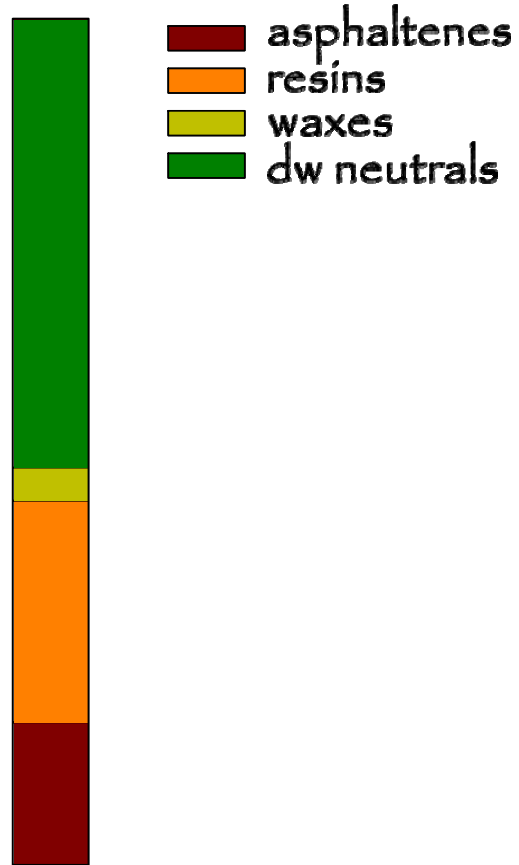

(height images)

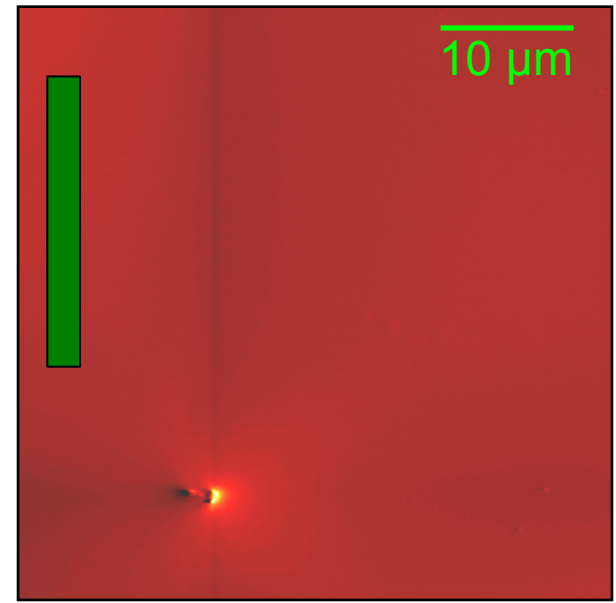
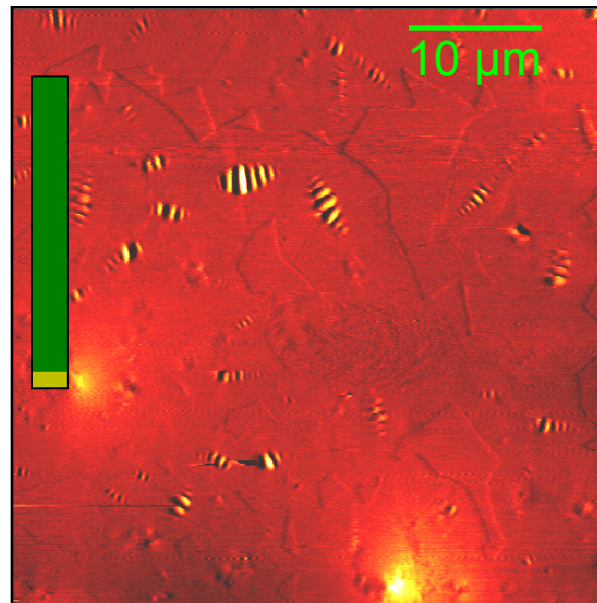
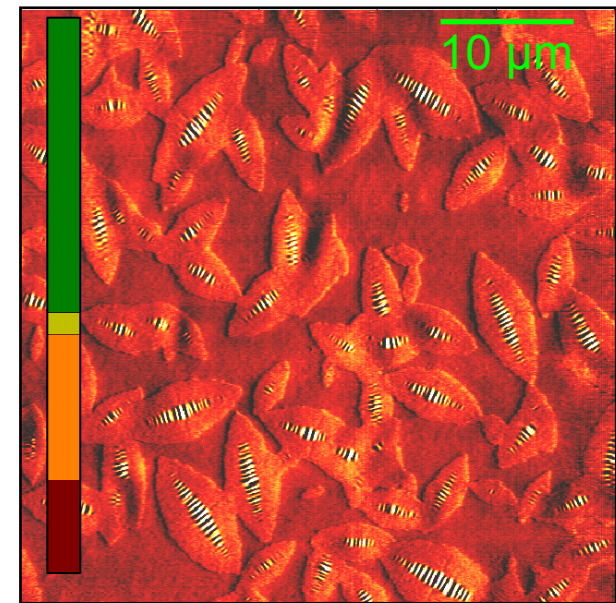
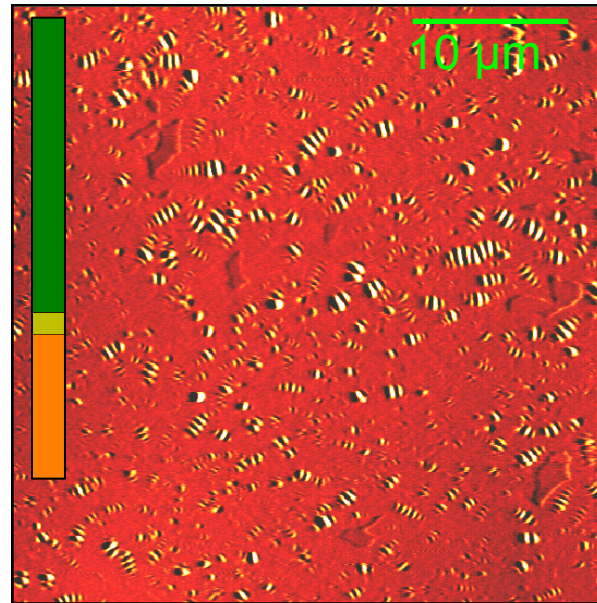

- **Microstructure evolution in asphalt mixes**

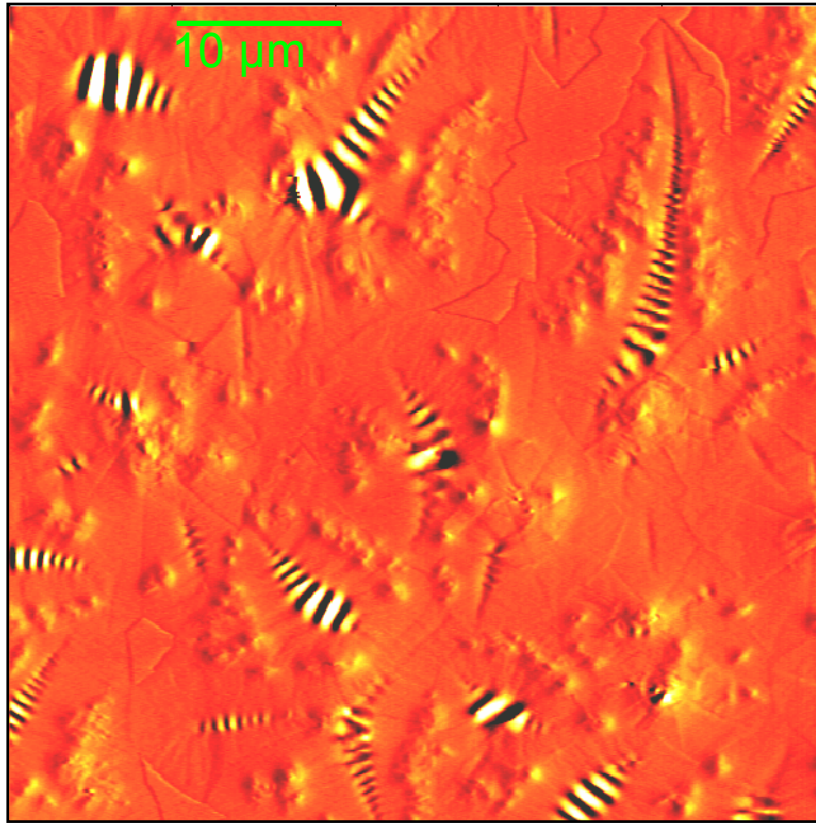
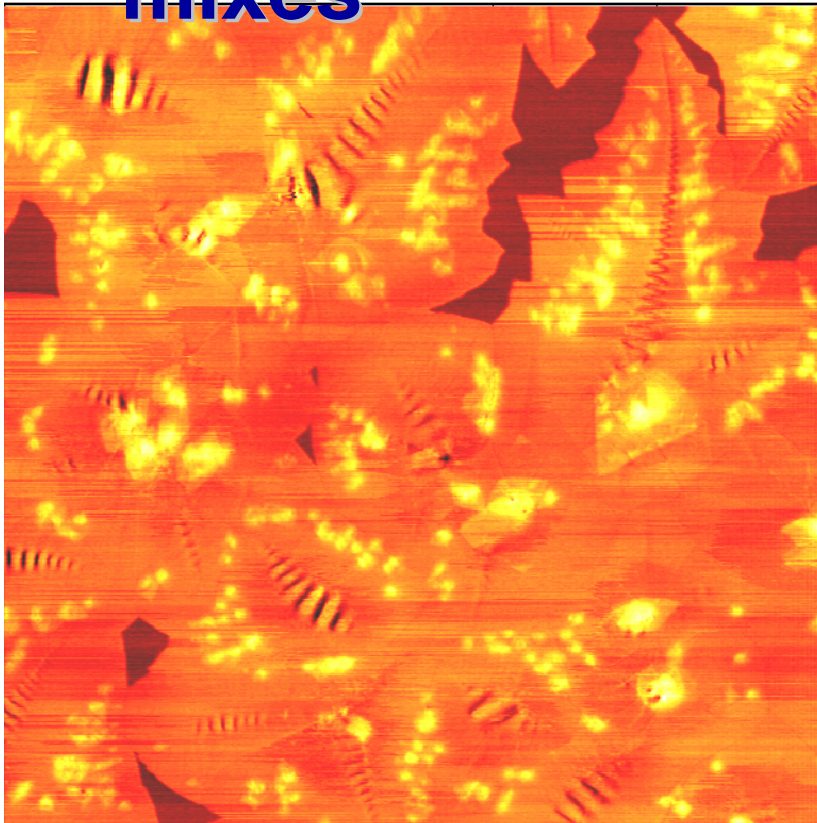

AAC-1

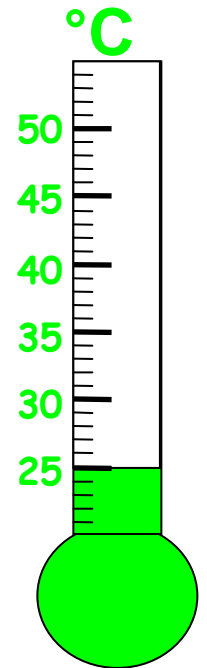

- **Microstructure evolution in asphalt mixes**

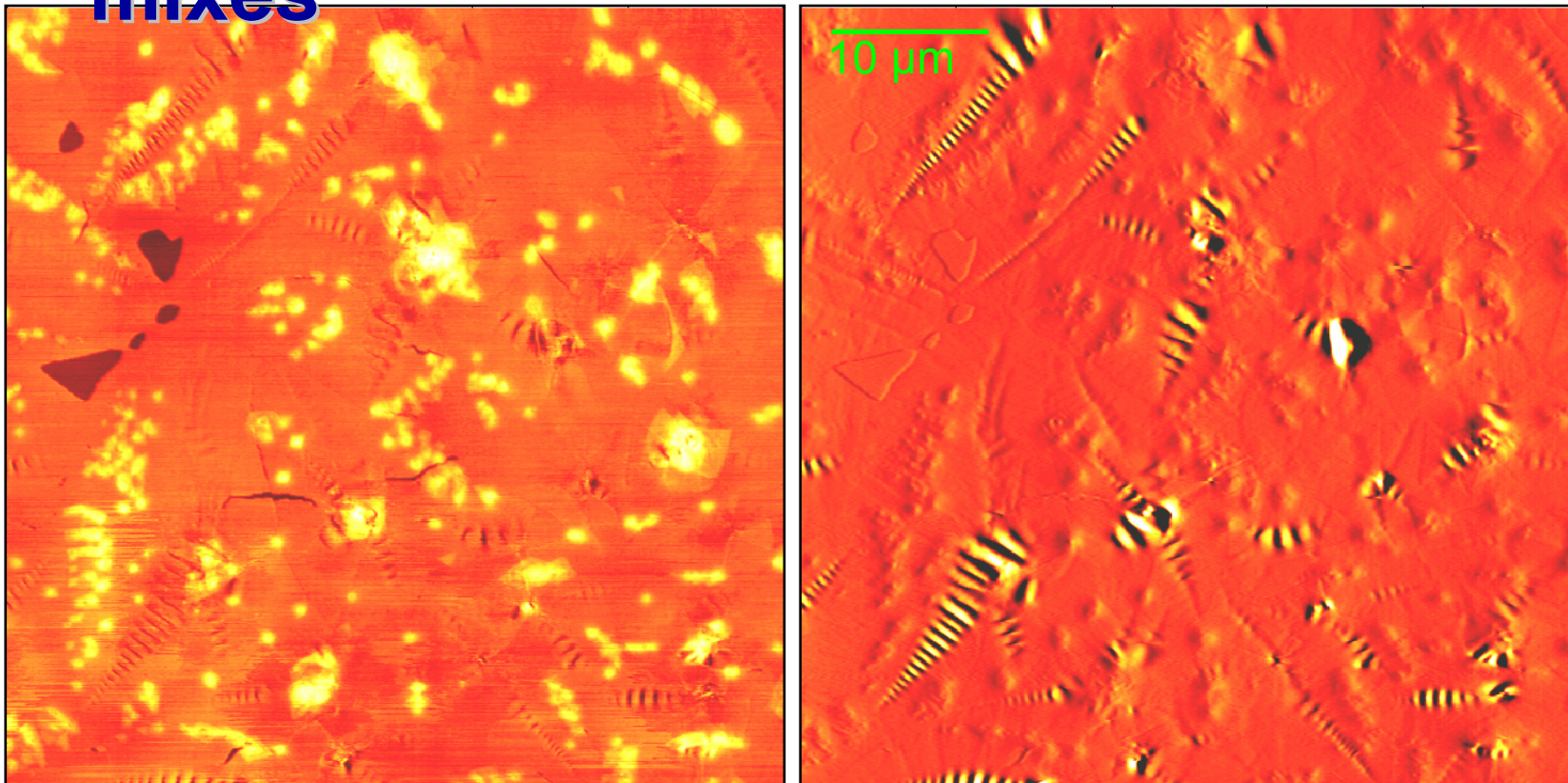

AAC-1

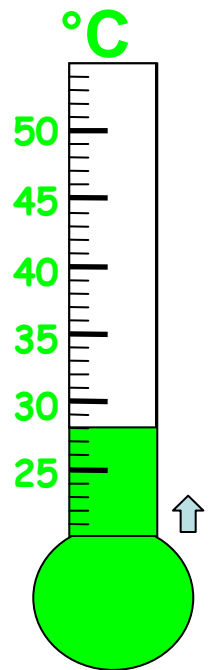

- **Microstructure evolution in asphalt mixes**

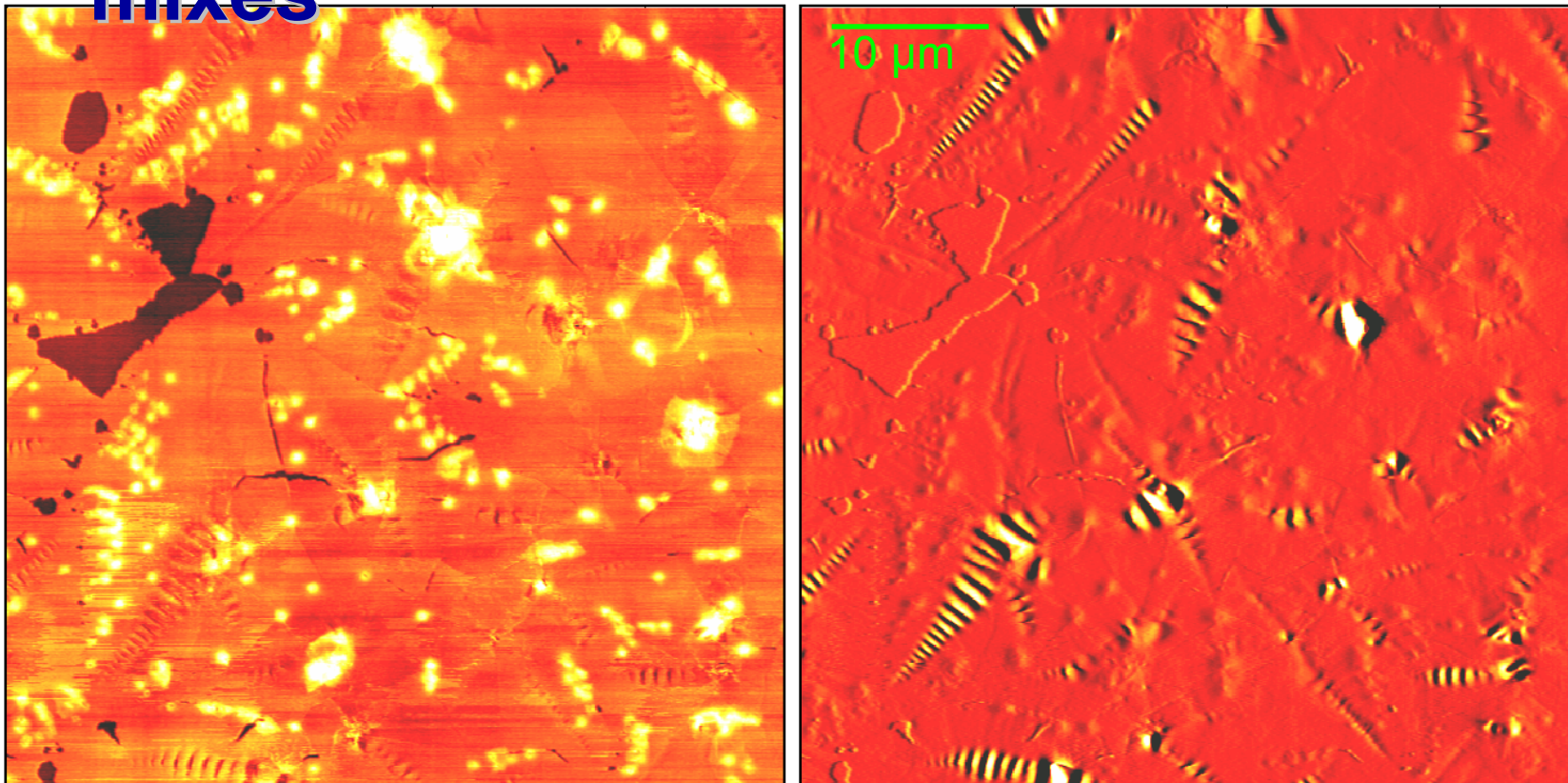

AAC-1

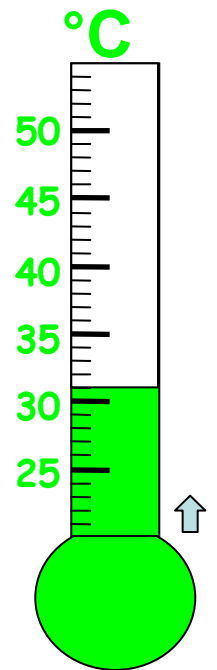

- **Microstructure evolution in asphalt mixes**

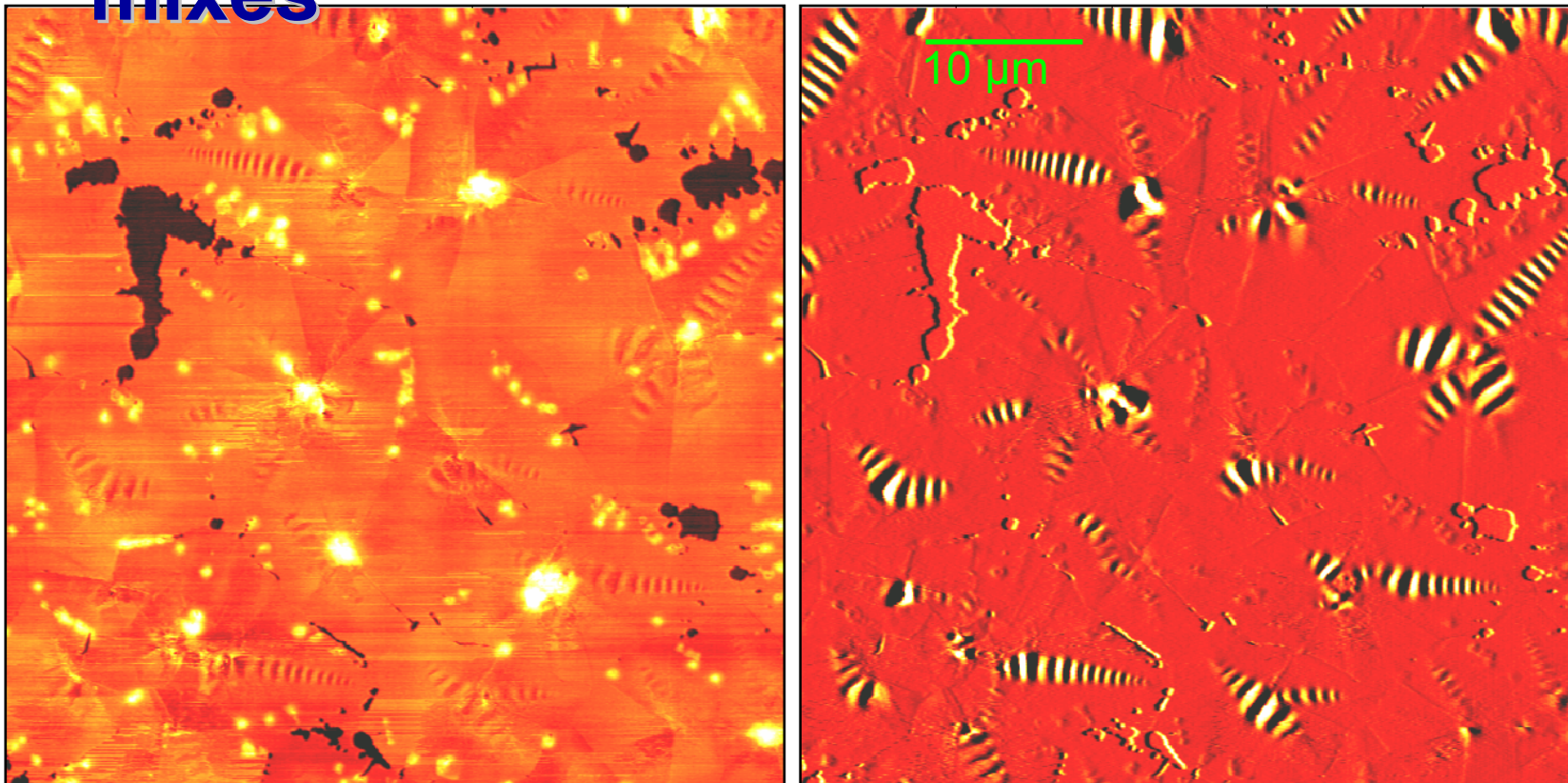

AAC-1

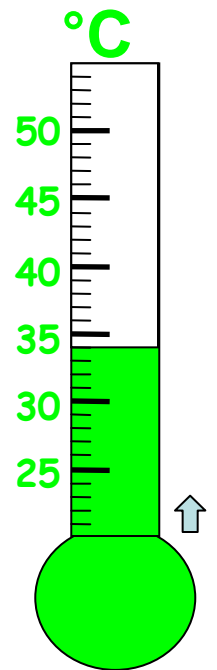

- **Microstructure evolution in asphalt mixes**

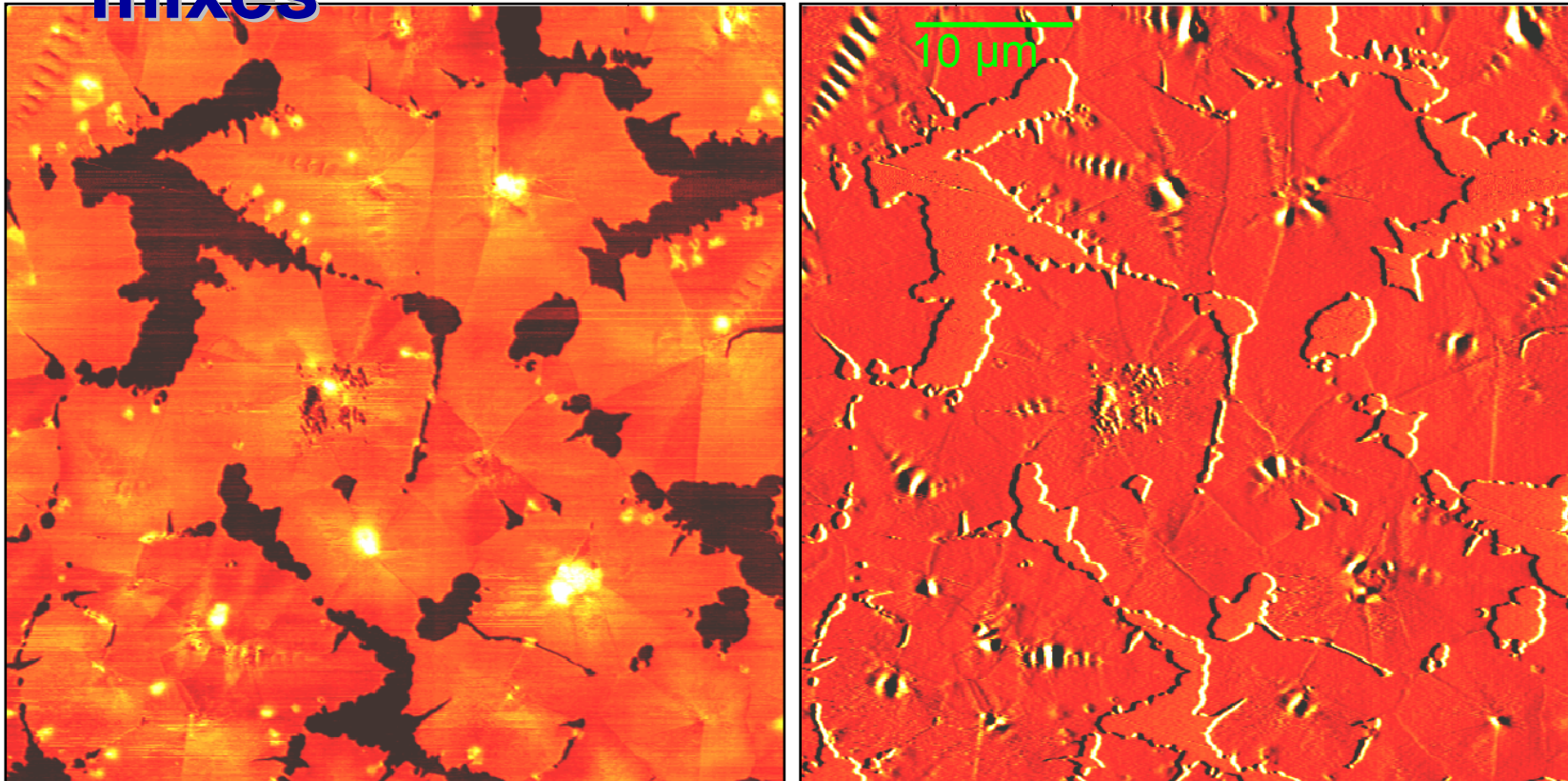

AAC-1

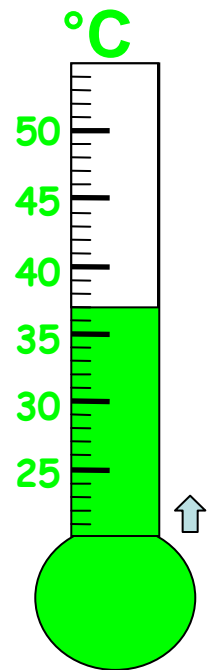

- **Microstructure evolution in asphalt mixes**

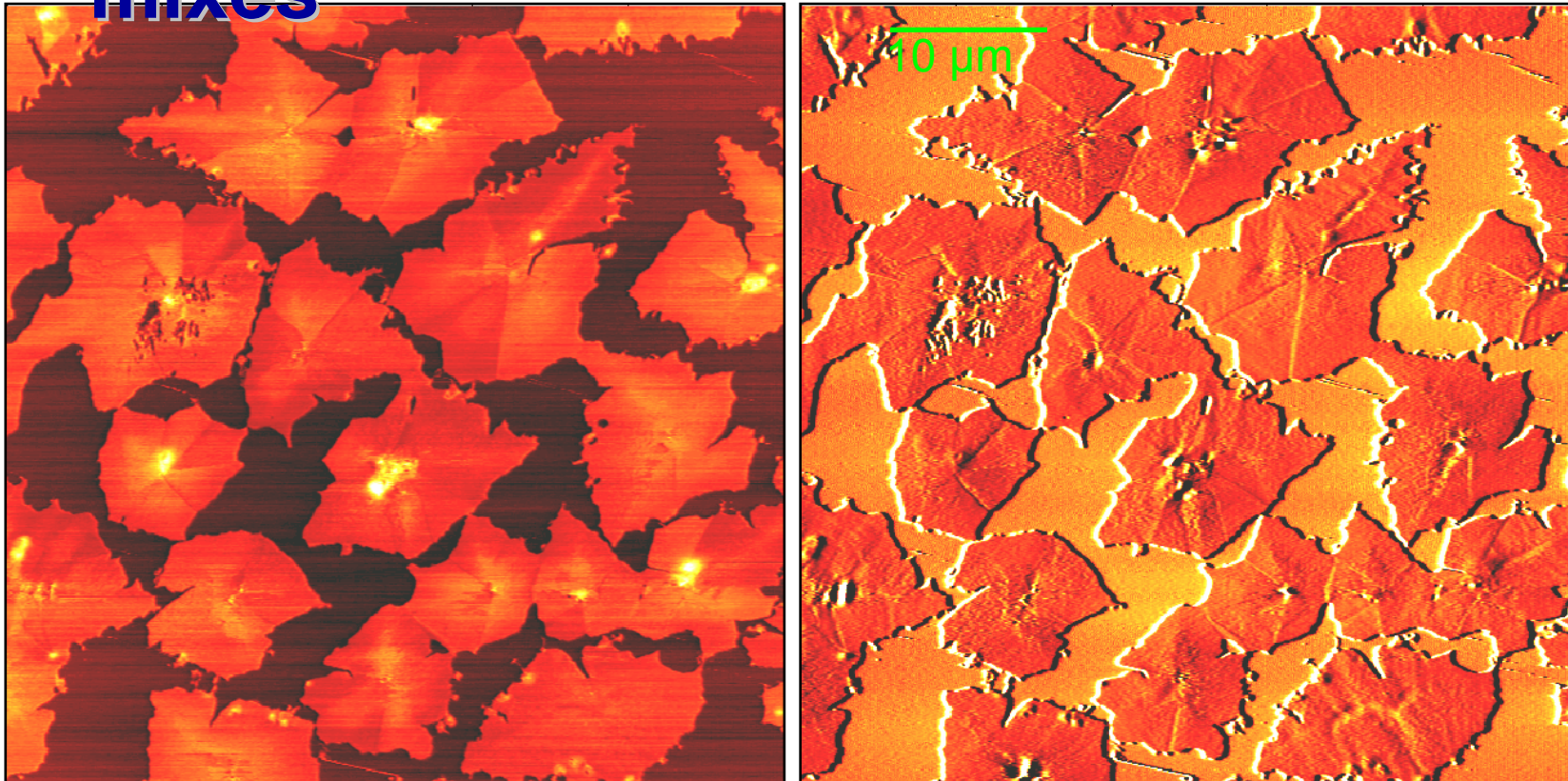

AAC-1

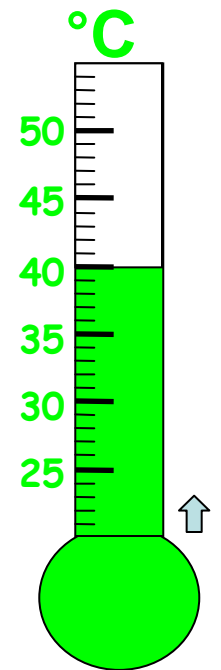

- **Microstructure evolution in asphalt mixes**

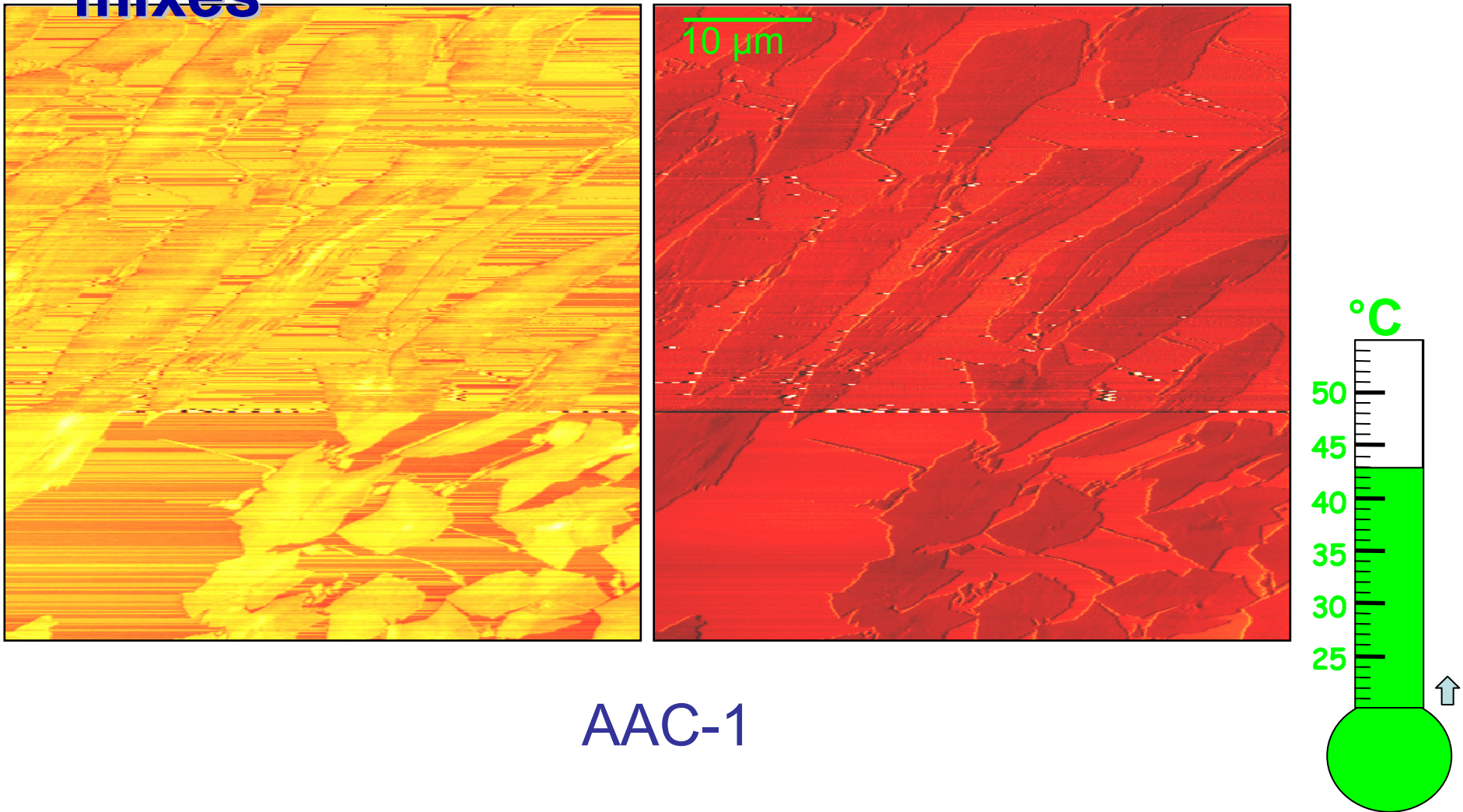

- **Microstructure evolution in asphalt mixes**

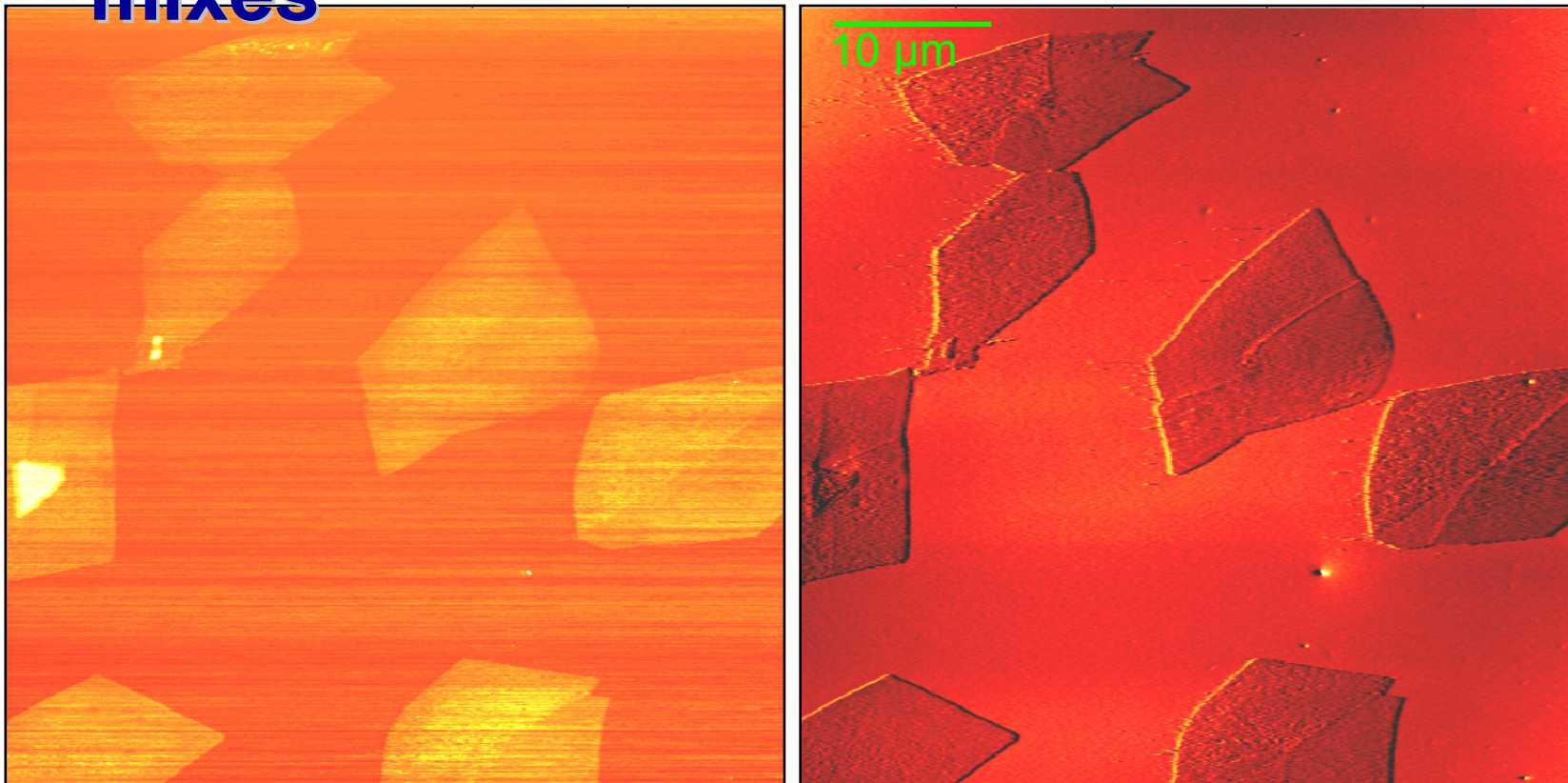

AAC-1

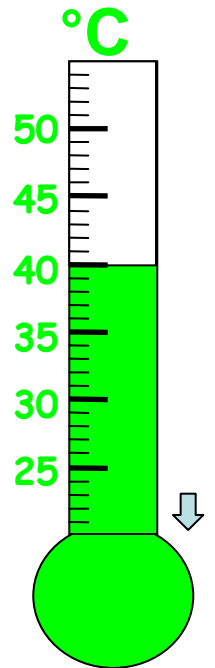

- **Microstructure evolution in asphalt mixes**

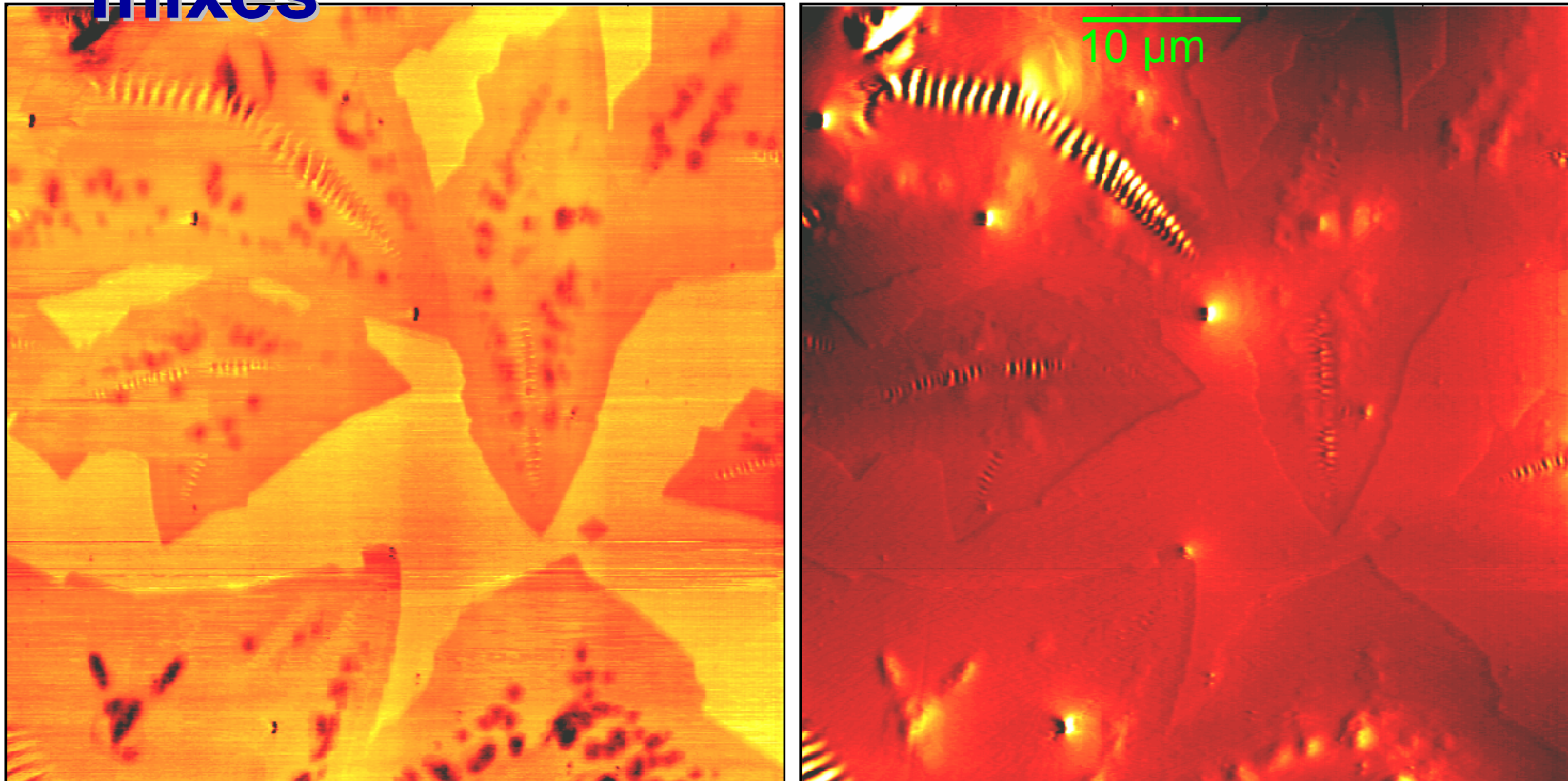

AAC-1

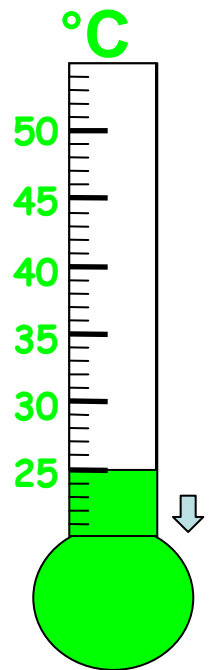

Asphalts

AAA-1

AAF-1

AAG-1

AAB-1

AAD-1

AAC-1

AAK-1

AAM-1

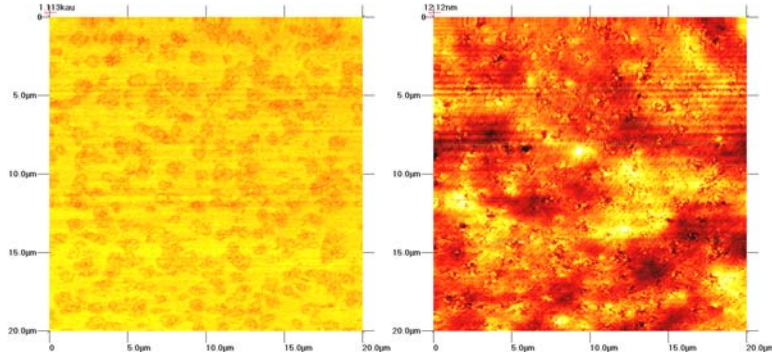
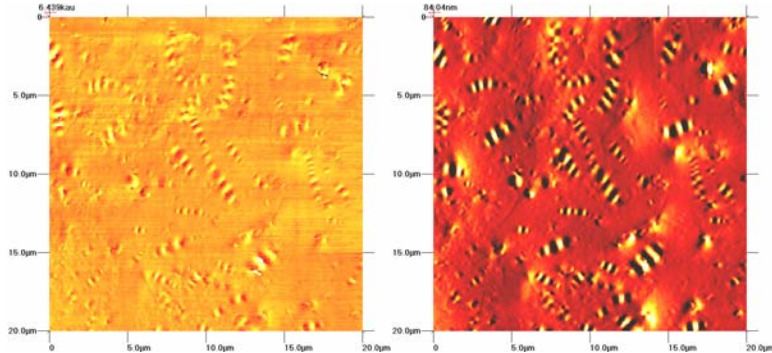
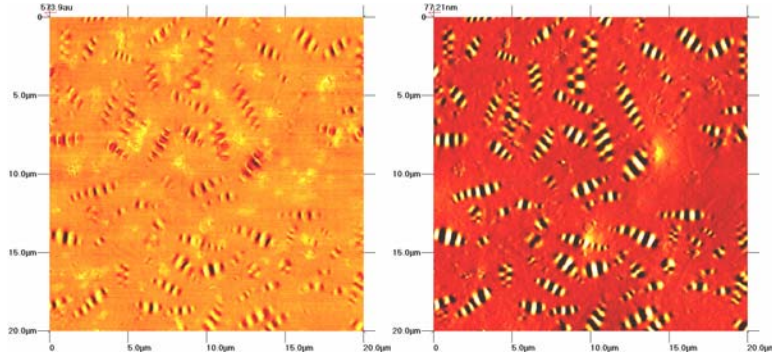
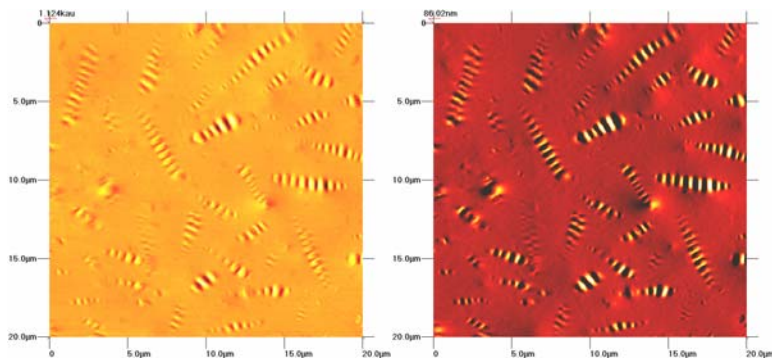
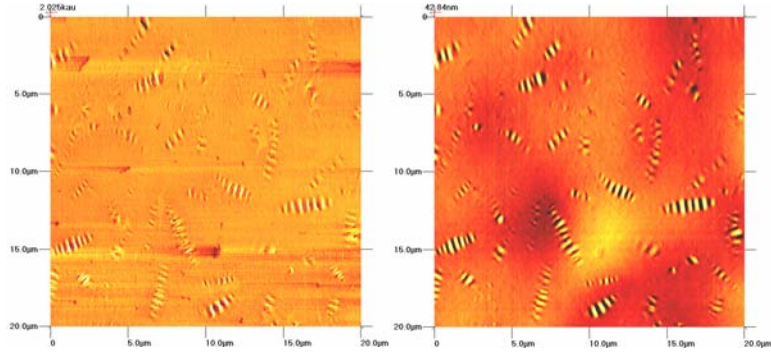
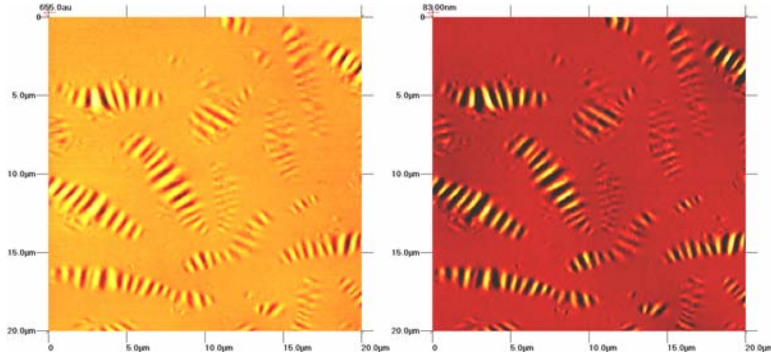
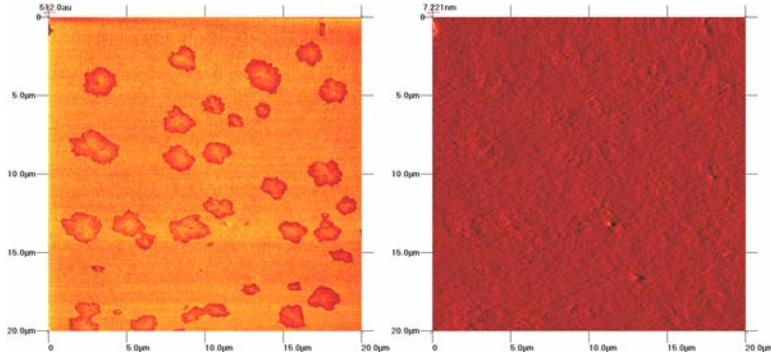
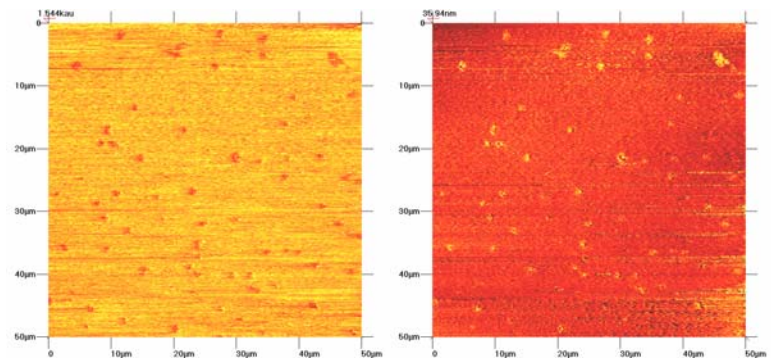

Mixing theory

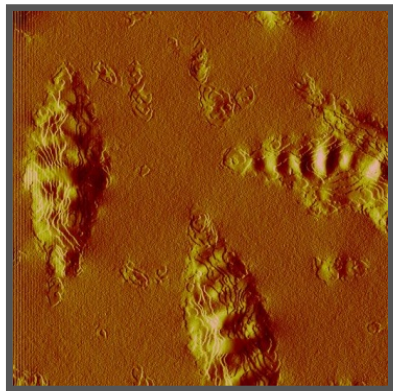

$T = 22 \text{ }^\circ\text{C}$



$-2 \text{ }^\circ\text{C/min}$



$T = 40 \text{ }^\circ\text{C}$

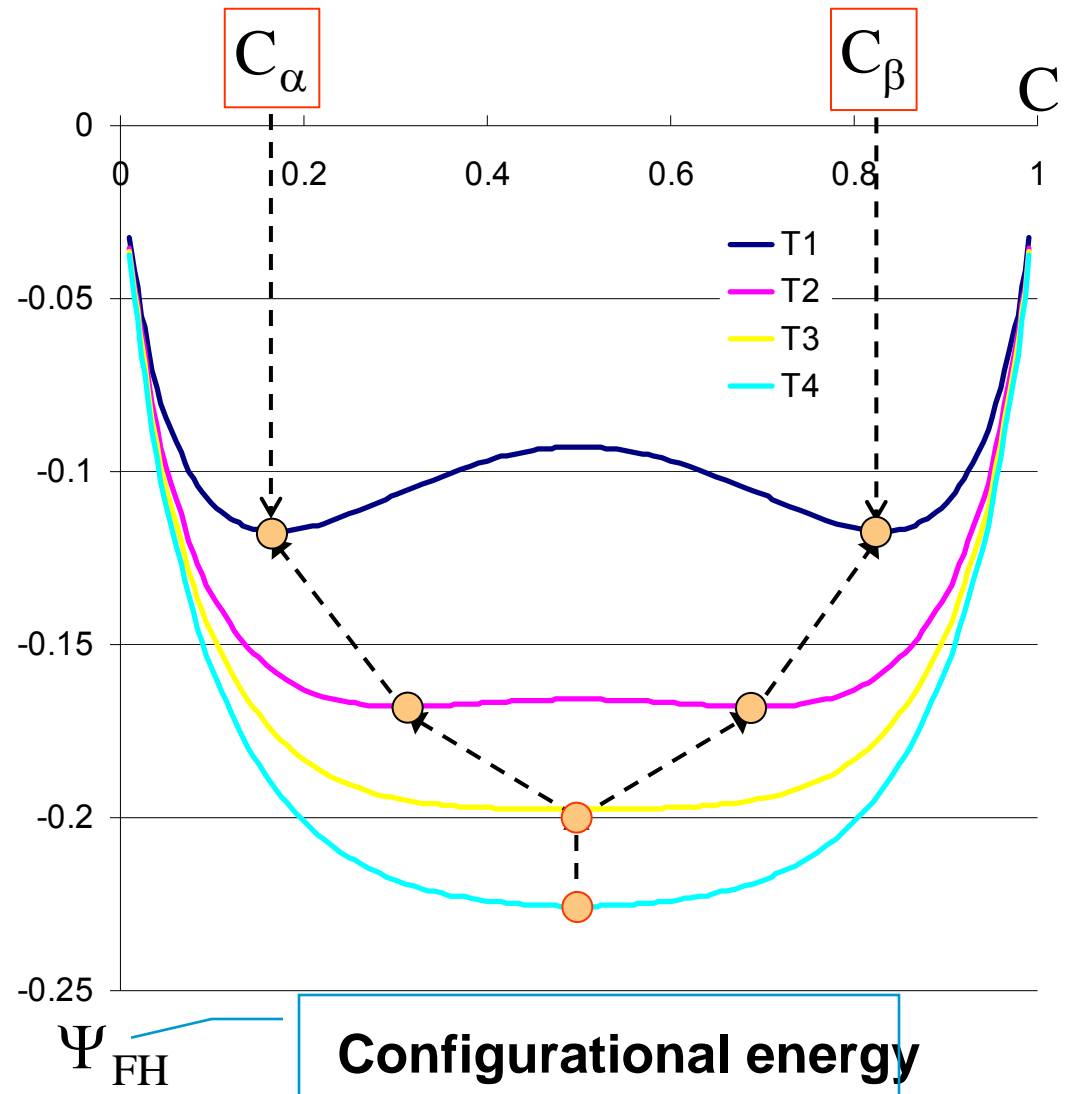

70/100 pen bitumen, AFM with heating element:

• Mixing theory

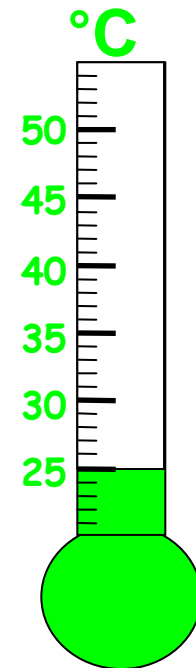
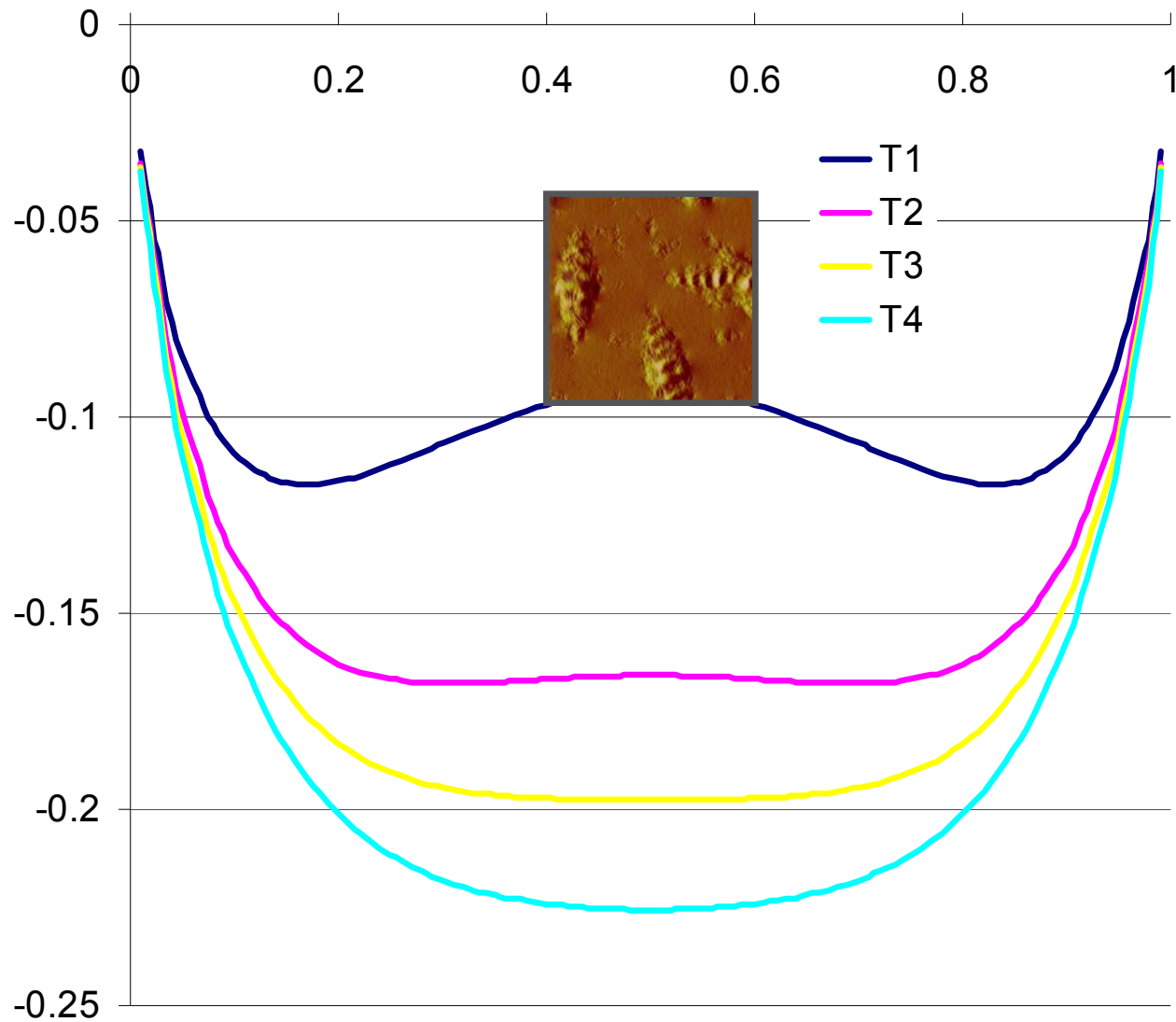

Mixing theory

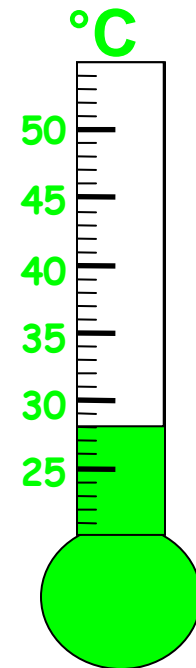
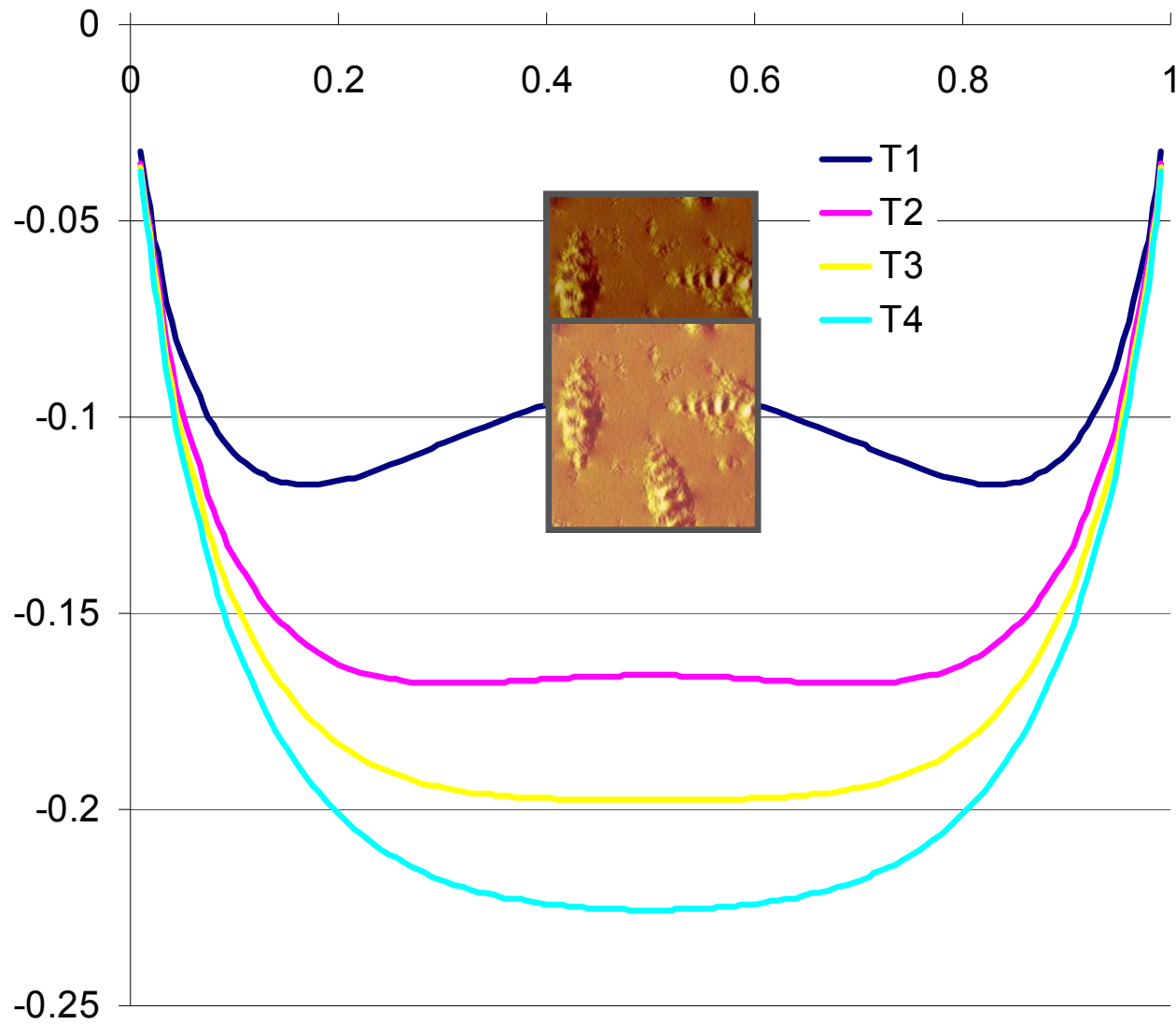

• Mixing theory

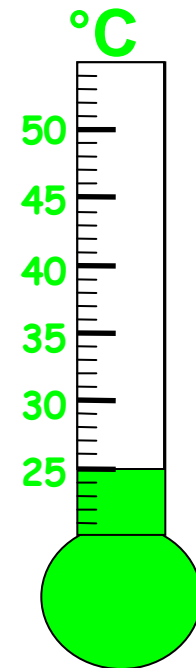
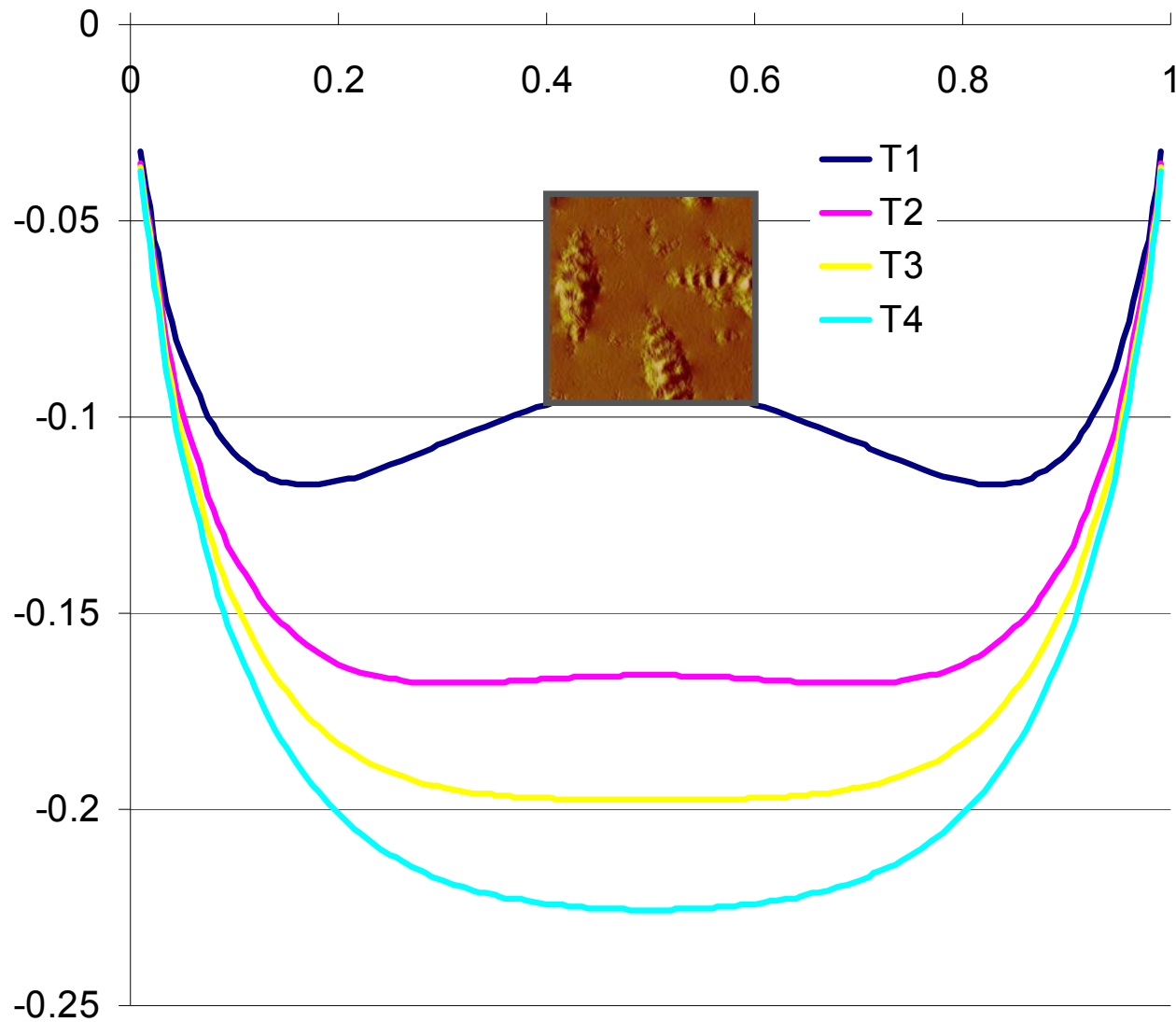

• Mixing theory

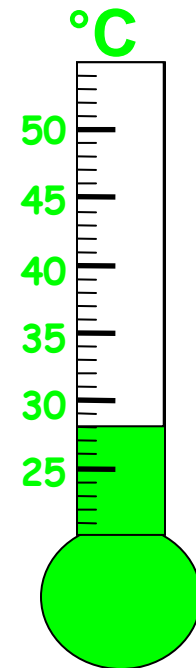
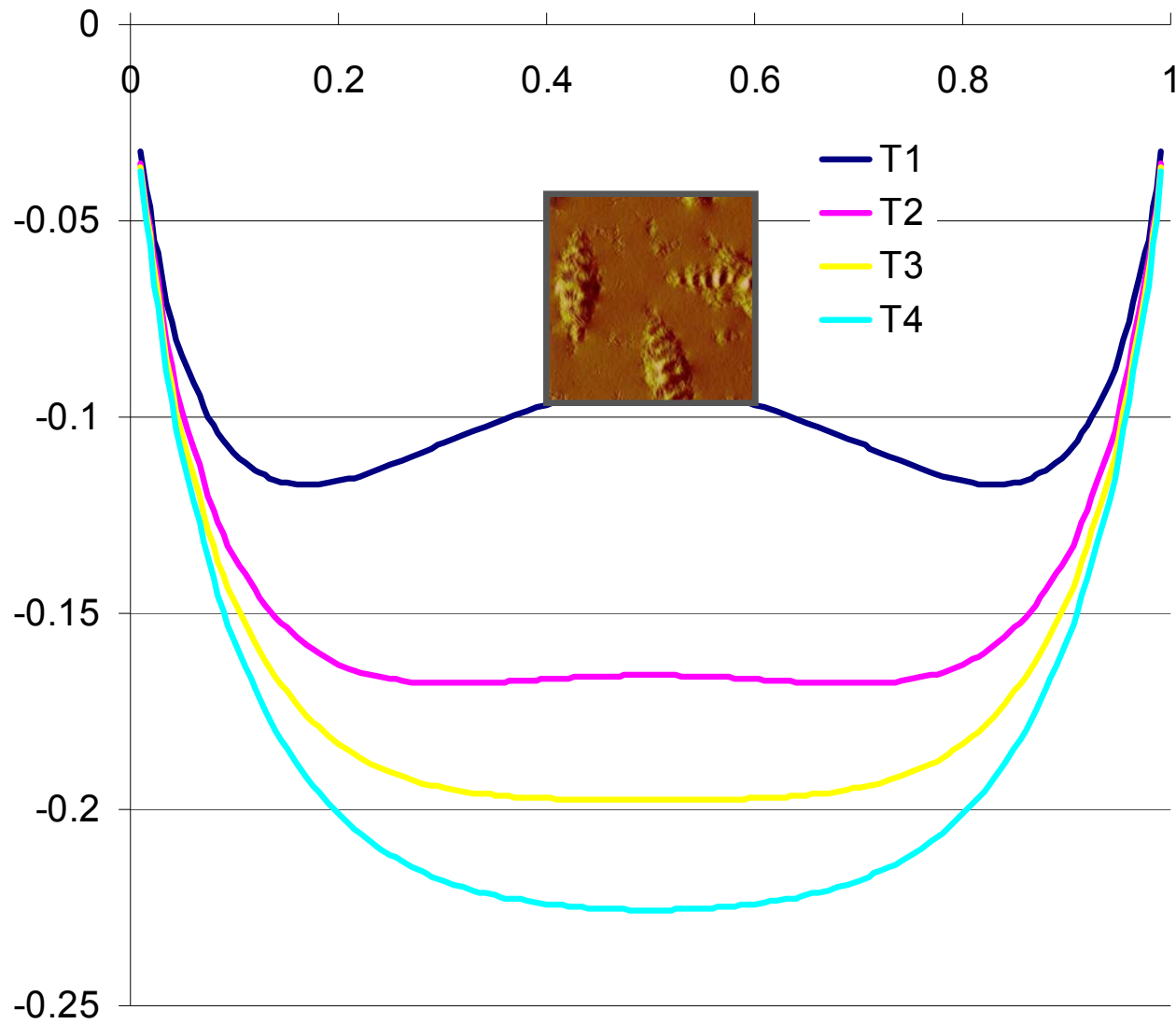

Mixing theory

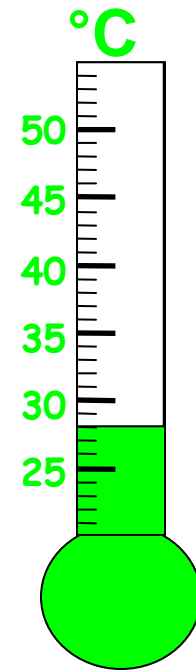
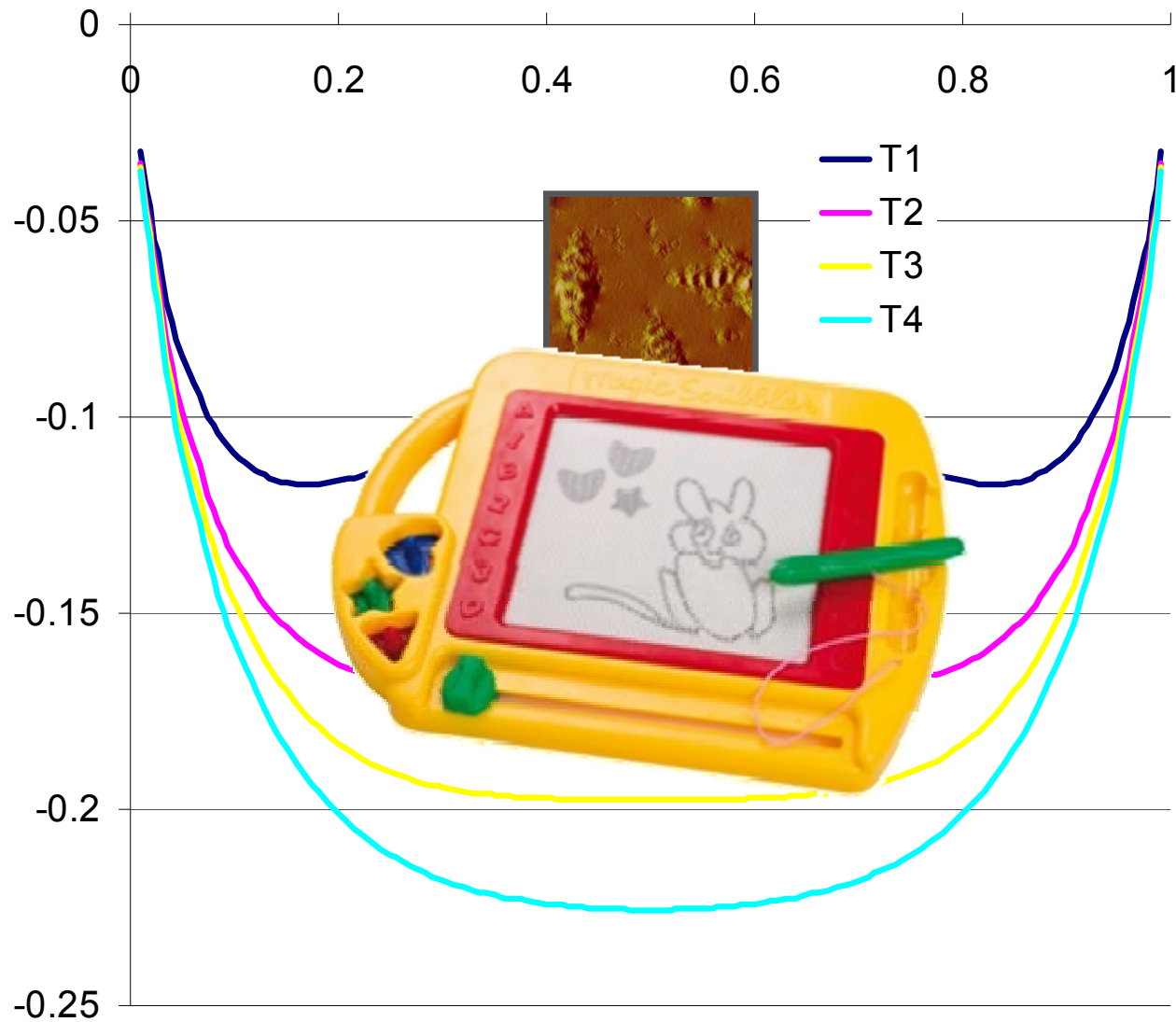

Mixing theory

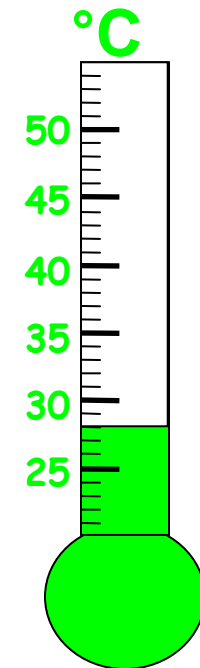
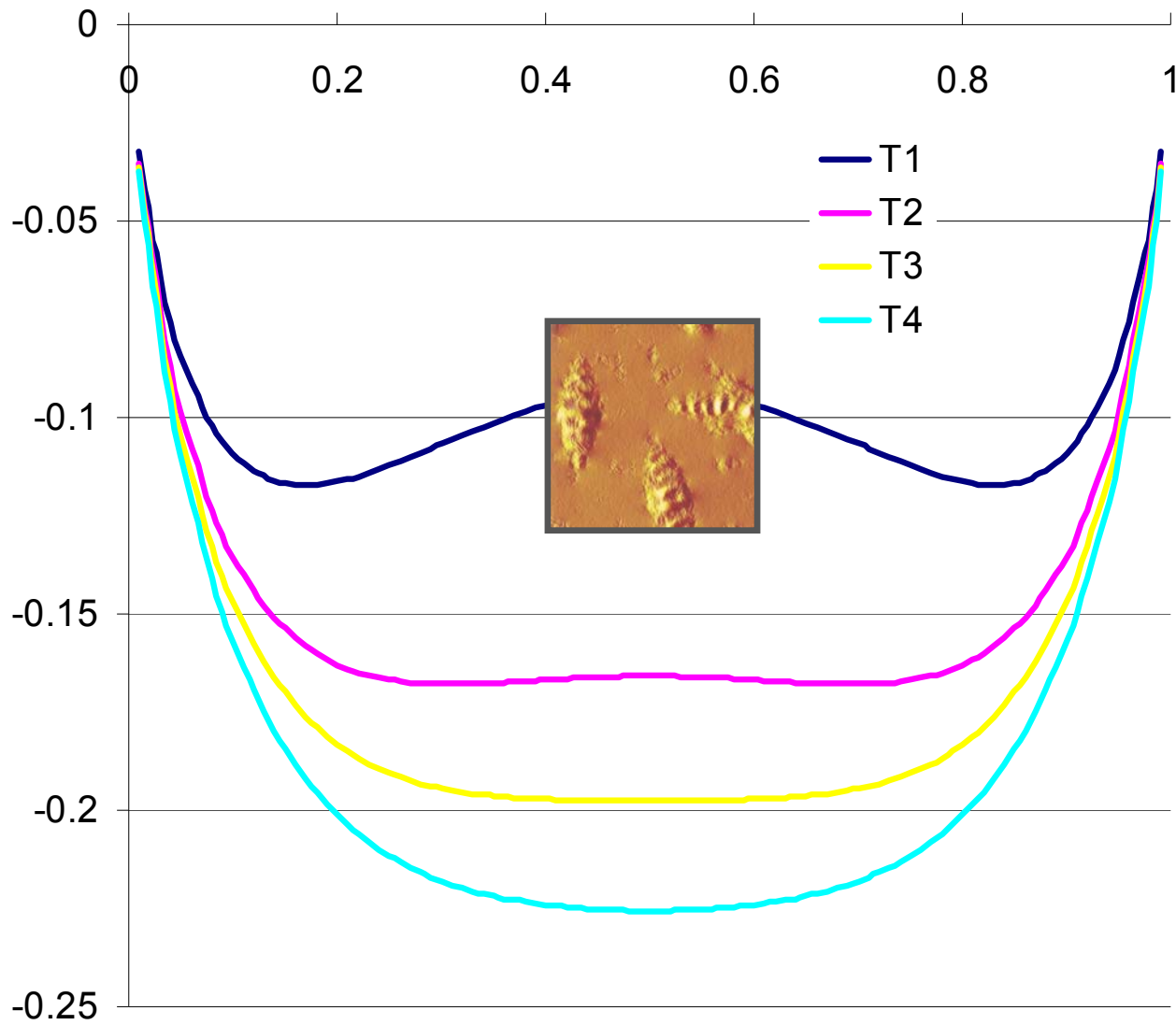

Mixing theory

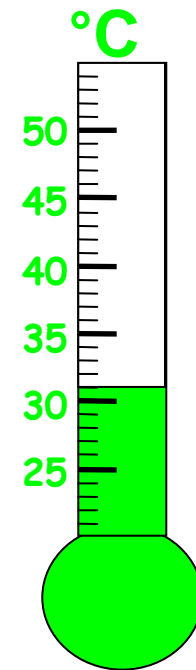
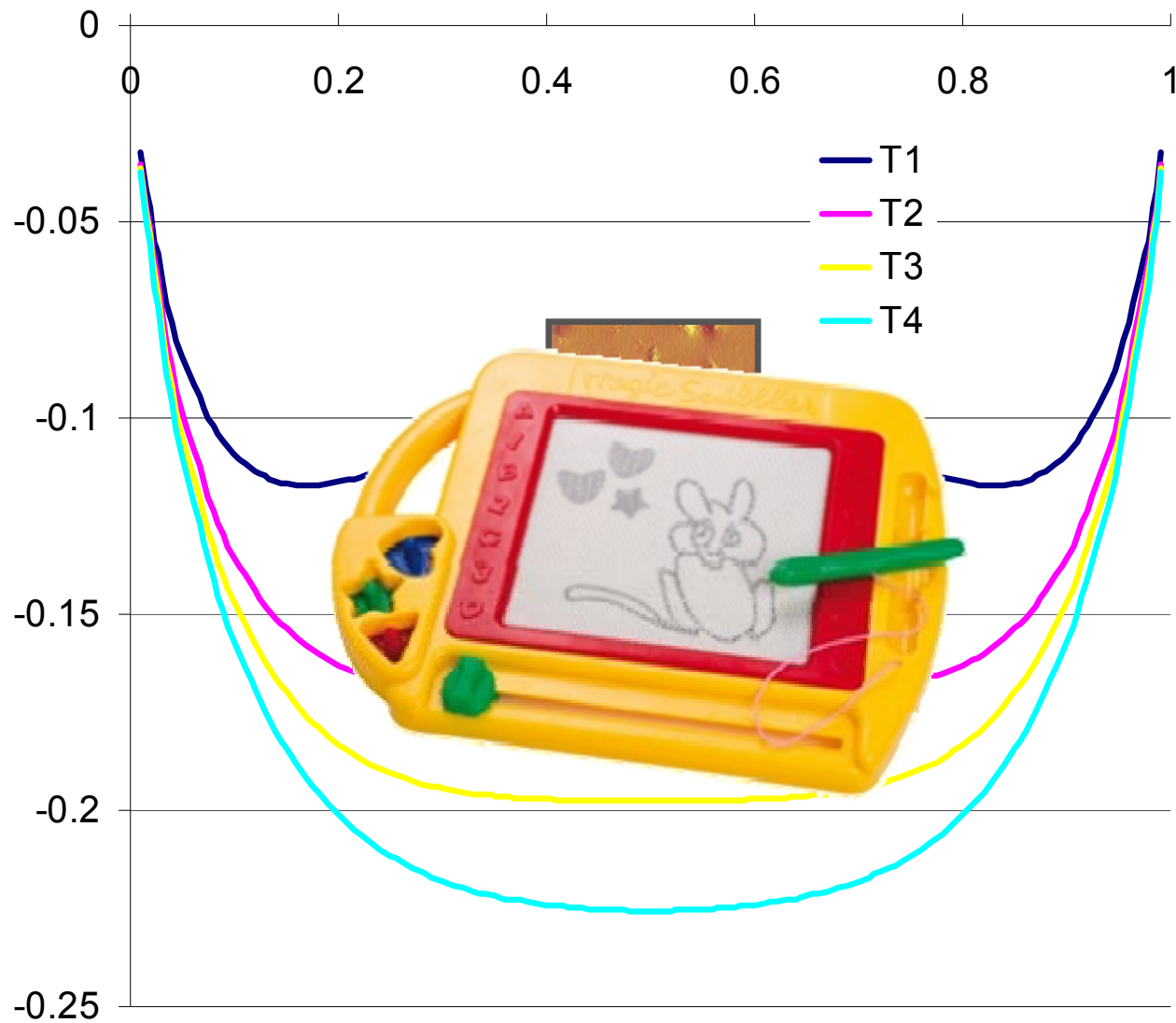

Mixing theory

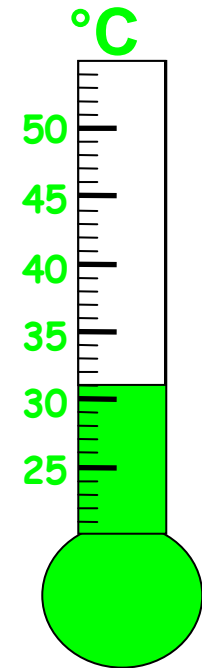
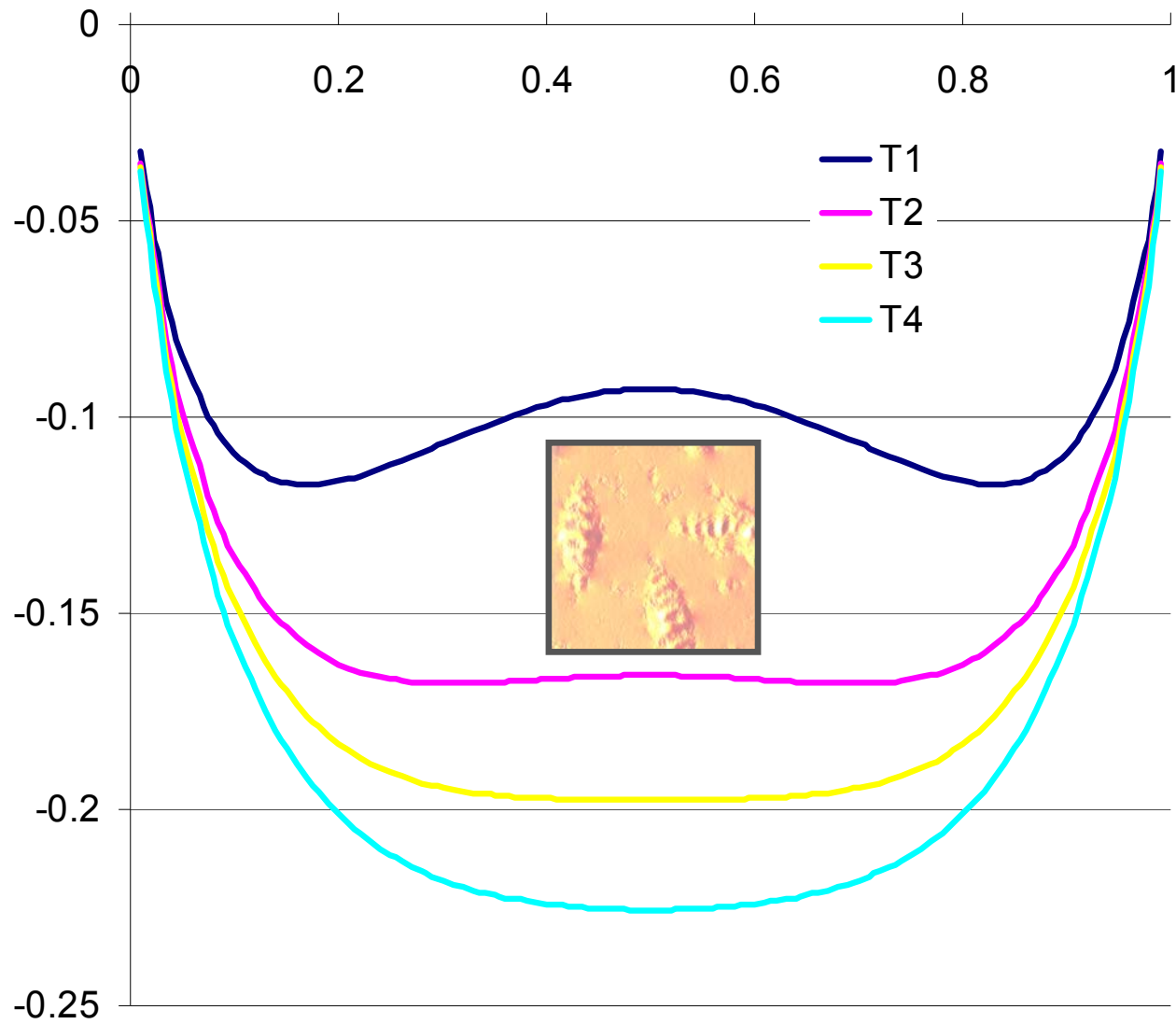

Mixing theory

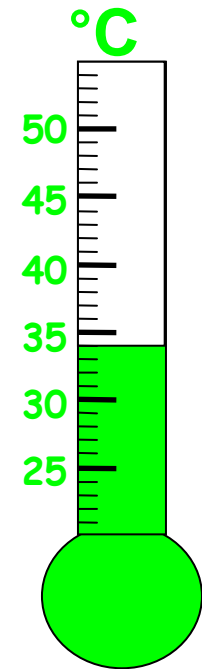
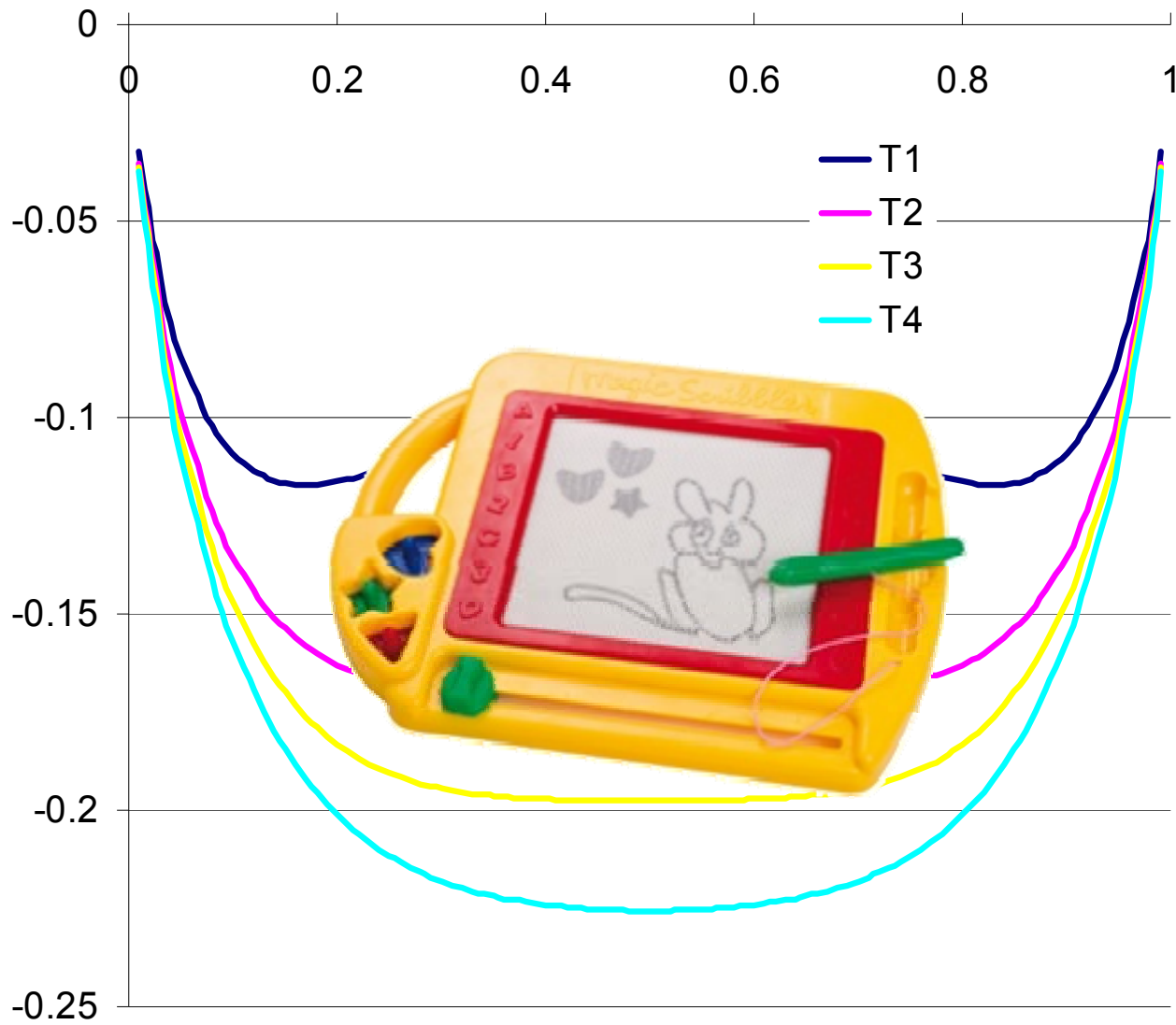

• Mixing theory

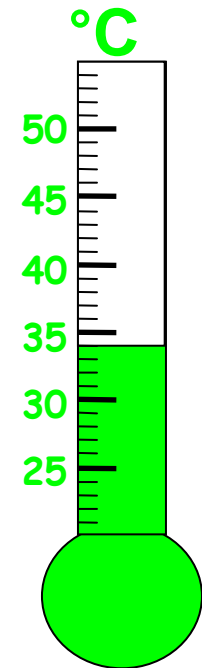
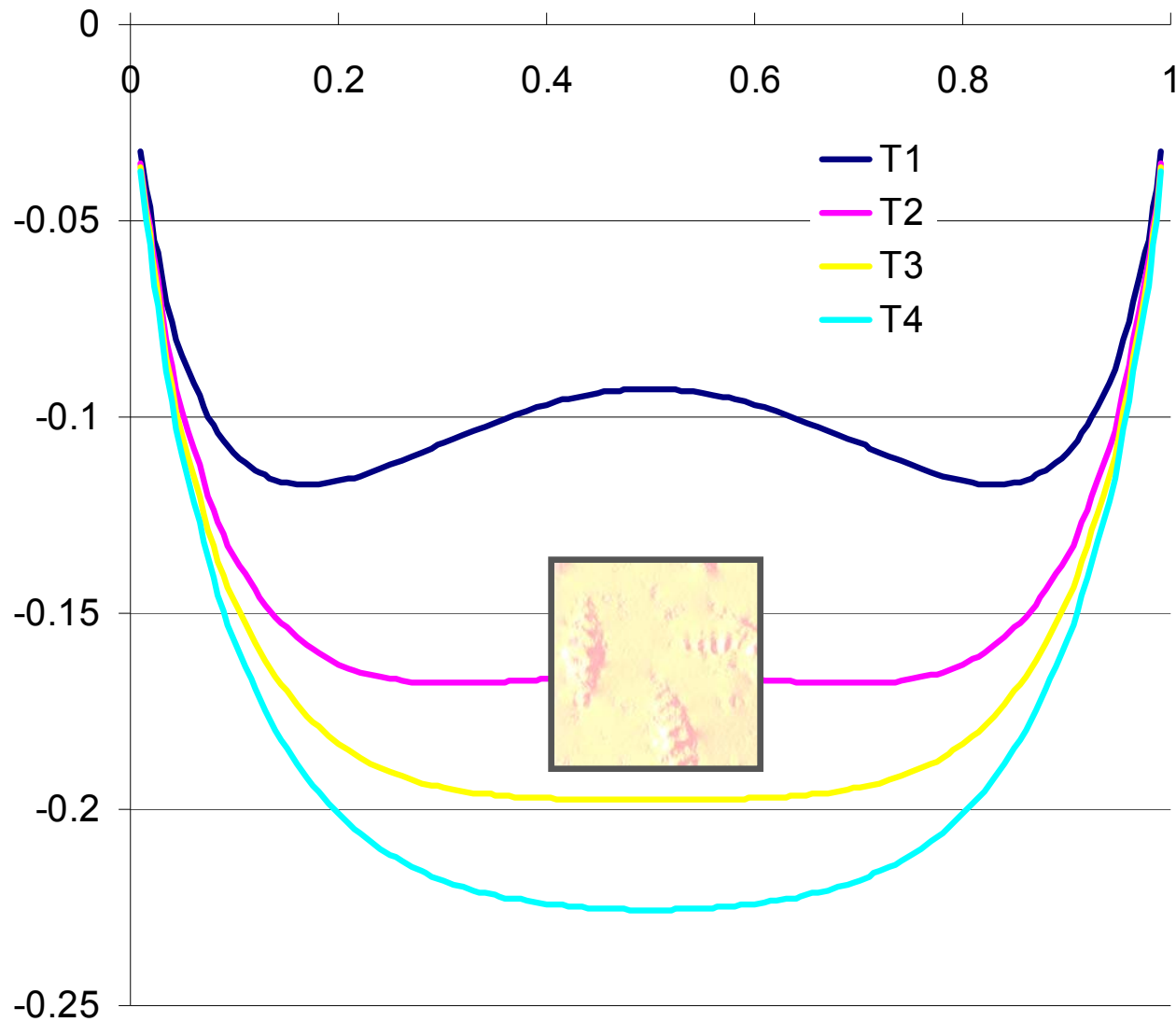

Mixing theory

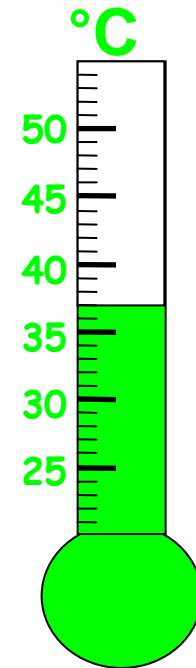
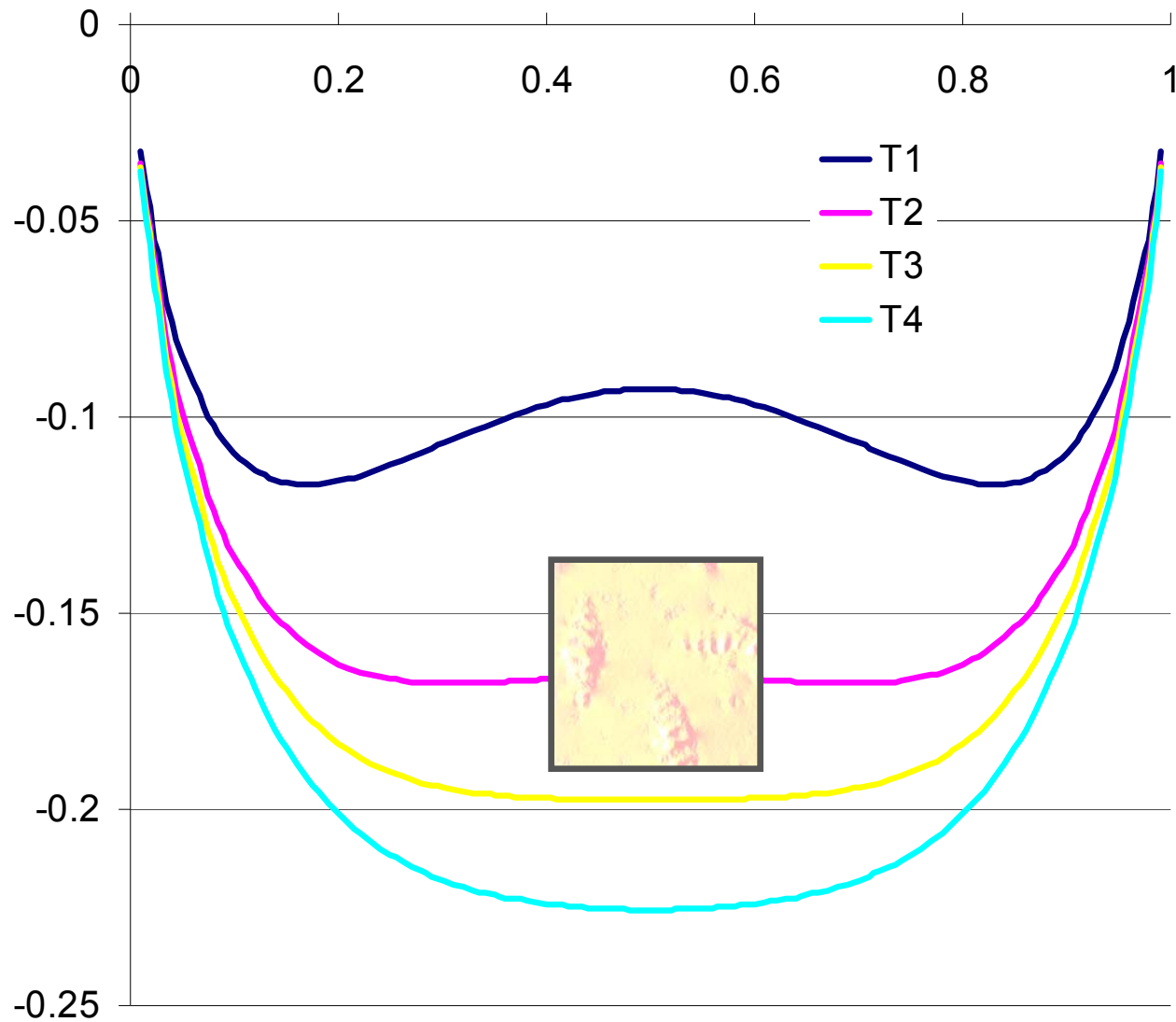

Mixing theory

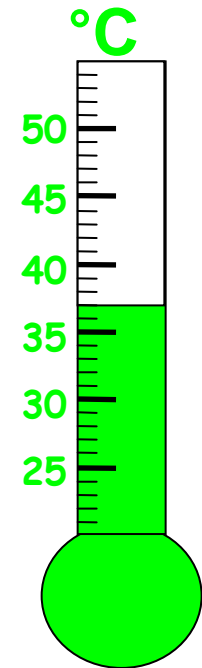
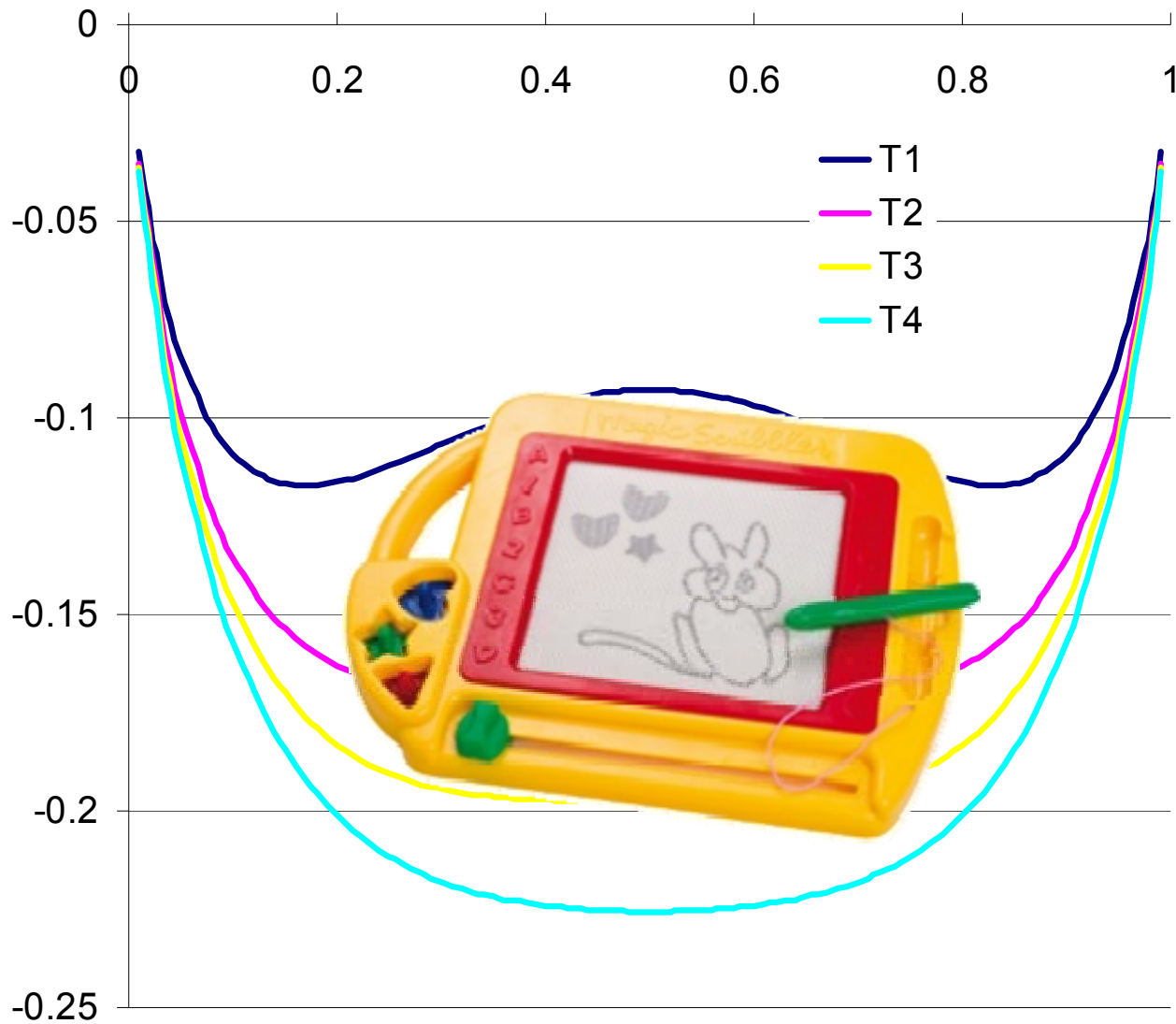

• Mixing theory

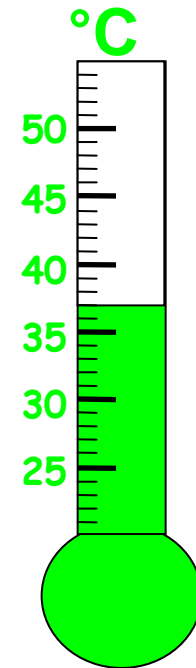
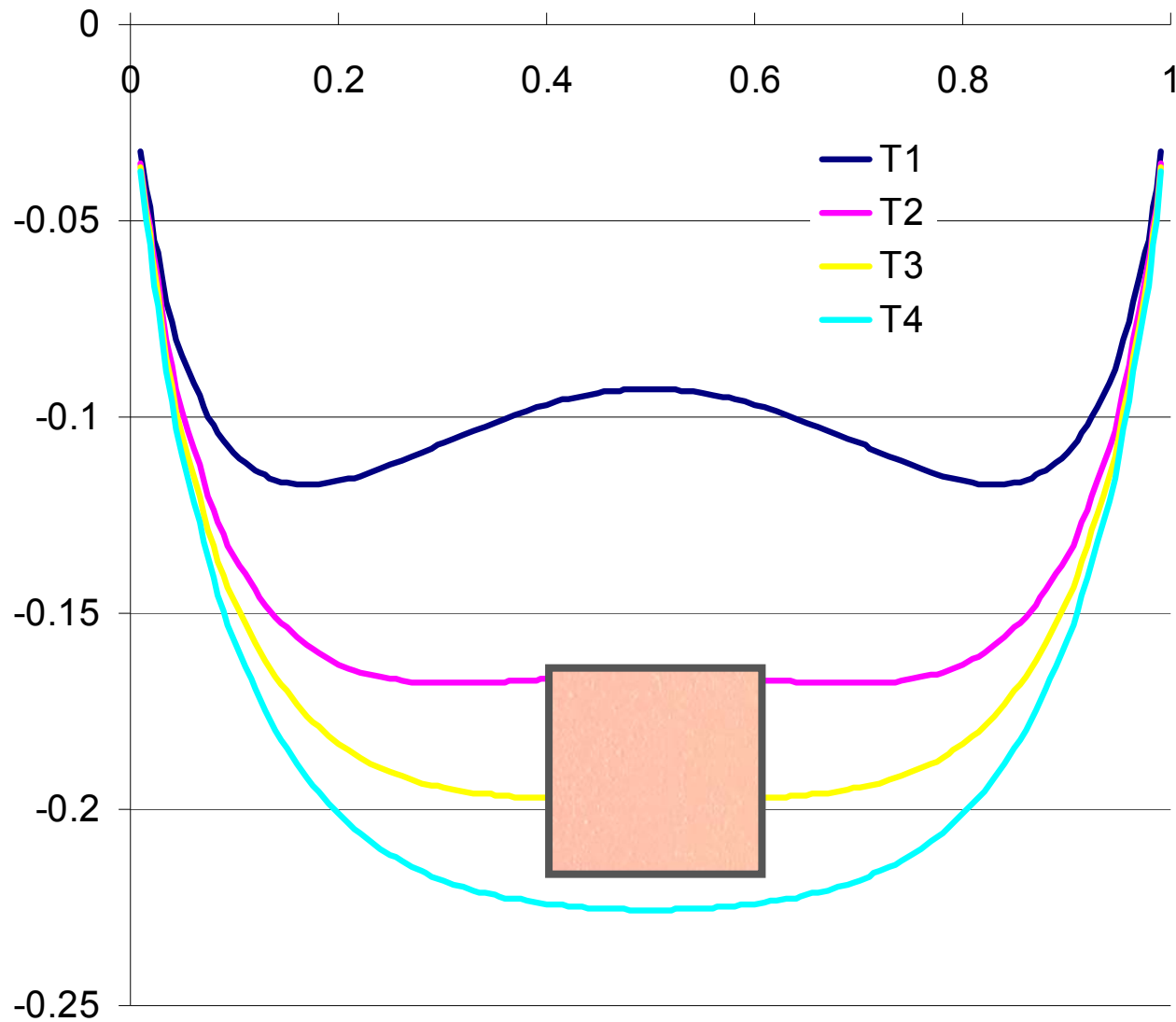

Mixing theory

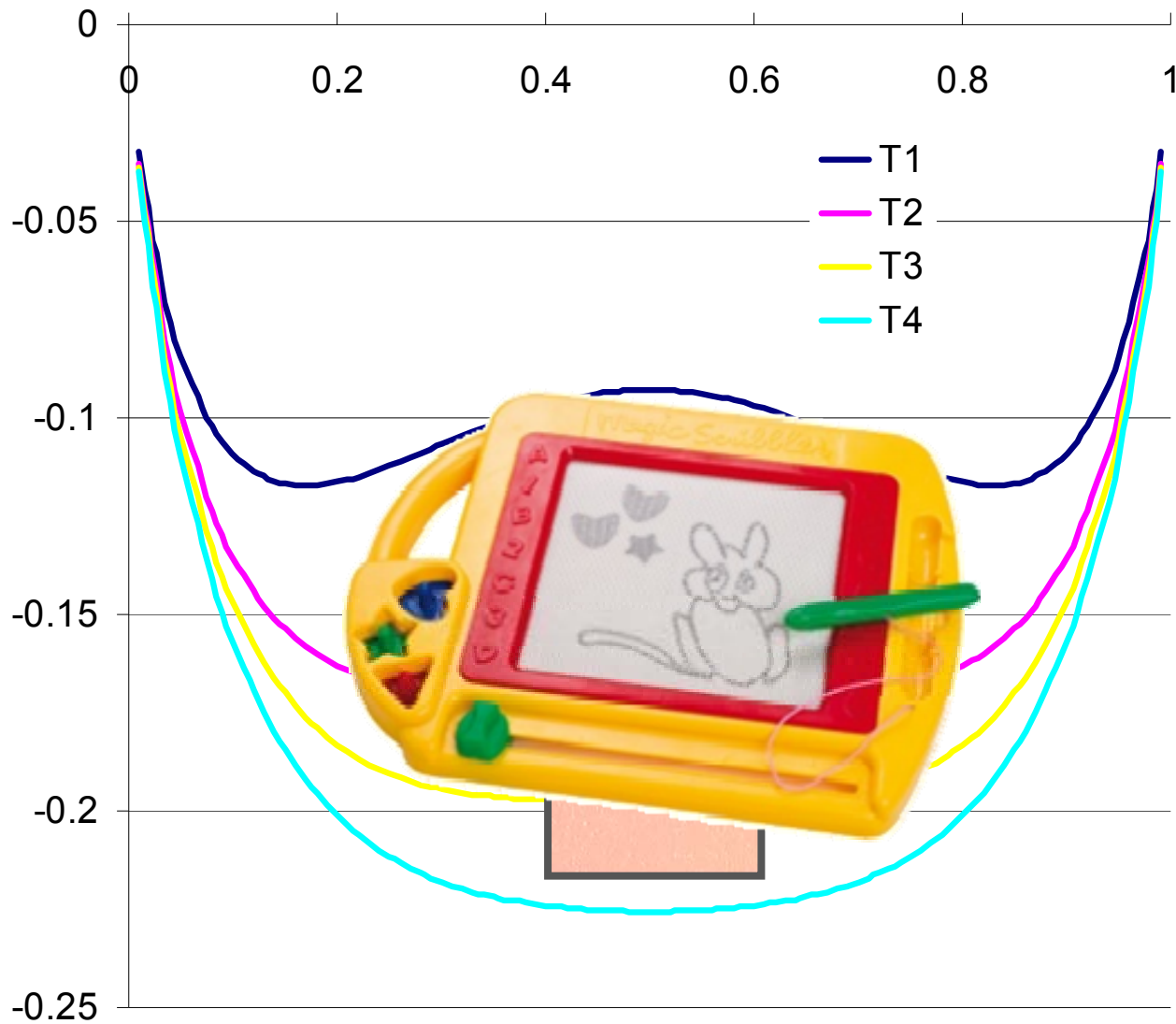

• Mixing theory

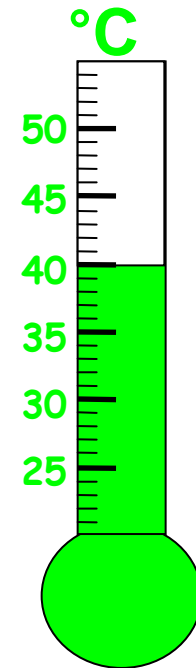
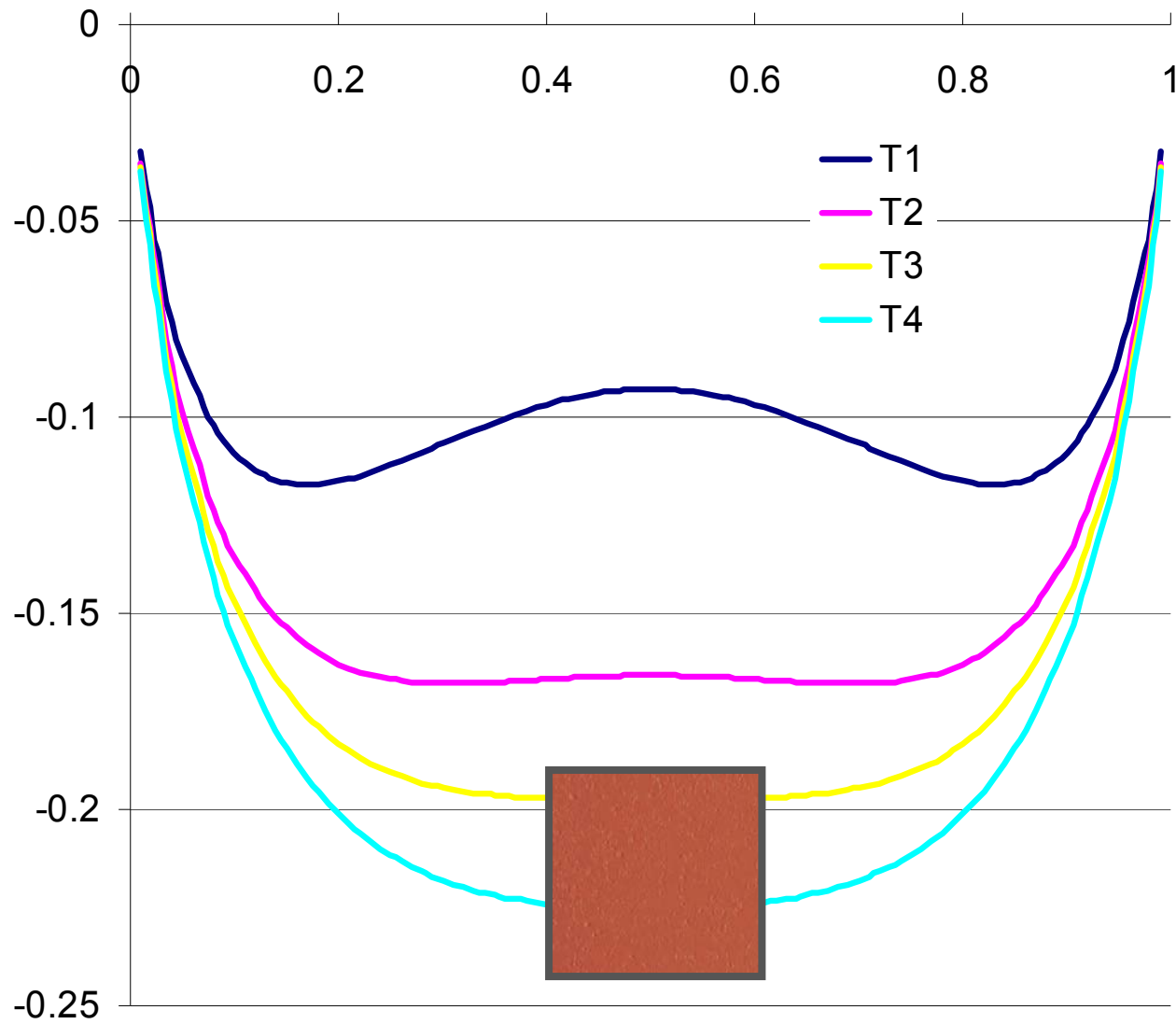

Mixing theory

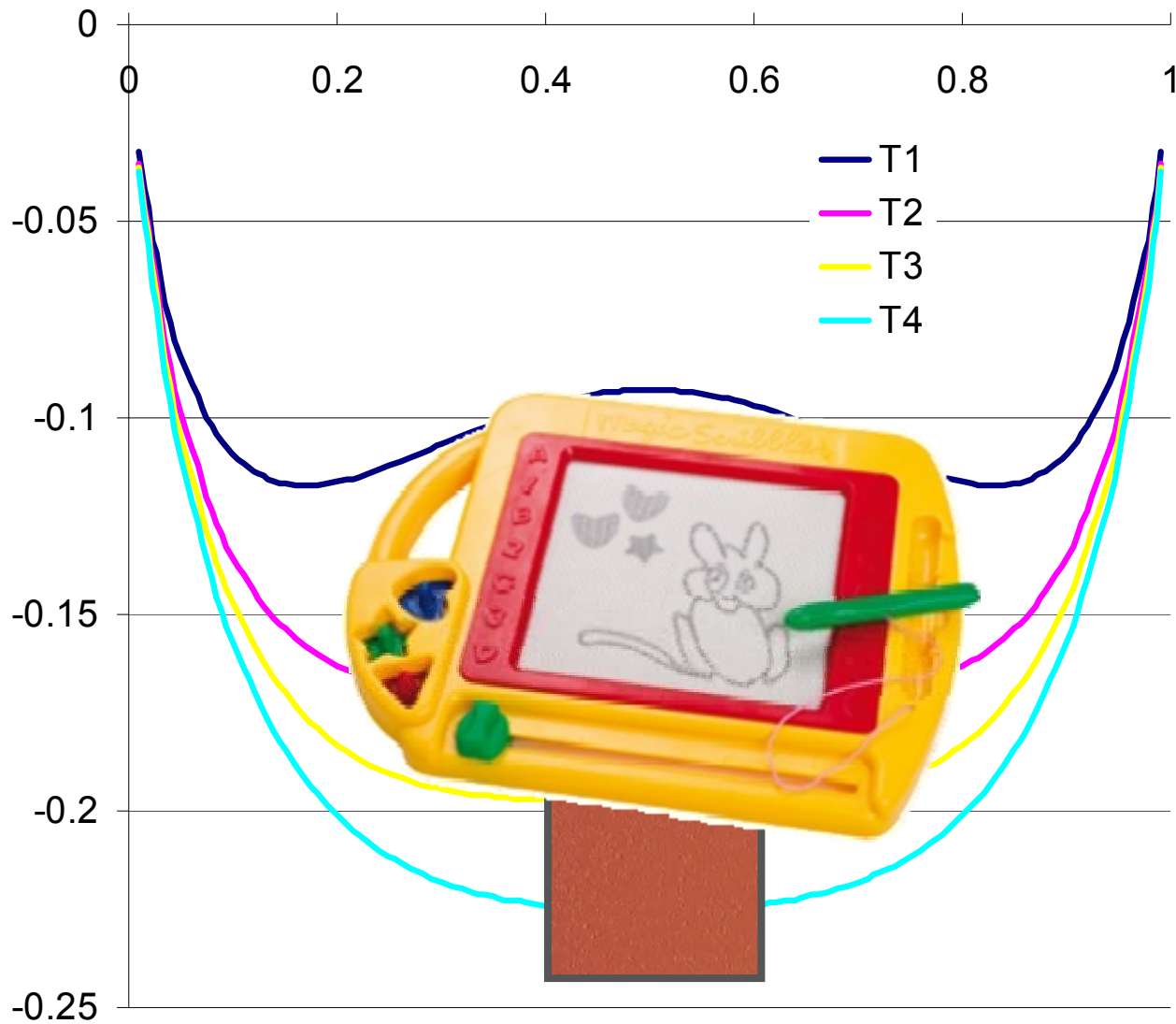

Mixing theory

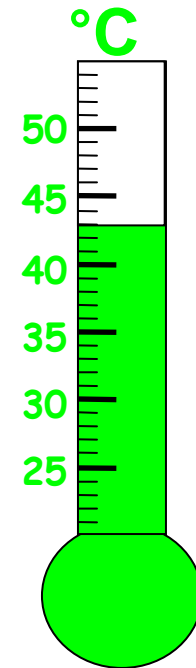
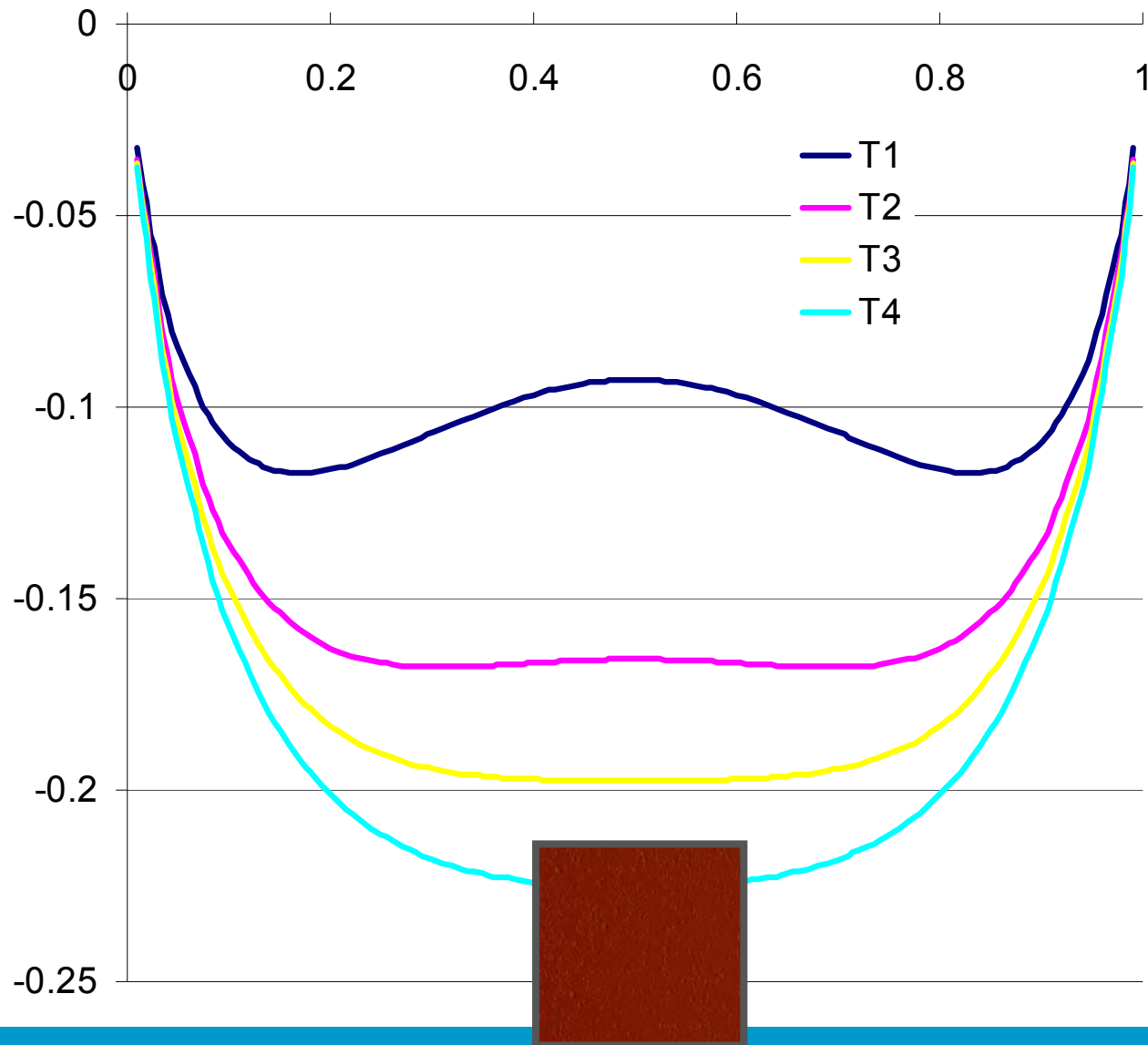

Mixing theory

Governing equation:

$$\rho_\alpha \frac{DC_\alpha}{Dt} - \text{div}(\rho_\alpha \underline{\underline{M}} \cdot \nabla \mu_\alpha) = 0$$

$$\nabla \mu_\alpha = \nabla \left(\frac{\delta \Psi_{FH}}{\delta C_\alpha} \right)$$

$$\underline{\underline{M}} = \sum_{i,j} M_{ij} \mathbf{e}_i \otimes \mathbf{e}_j$$

mobility tensor

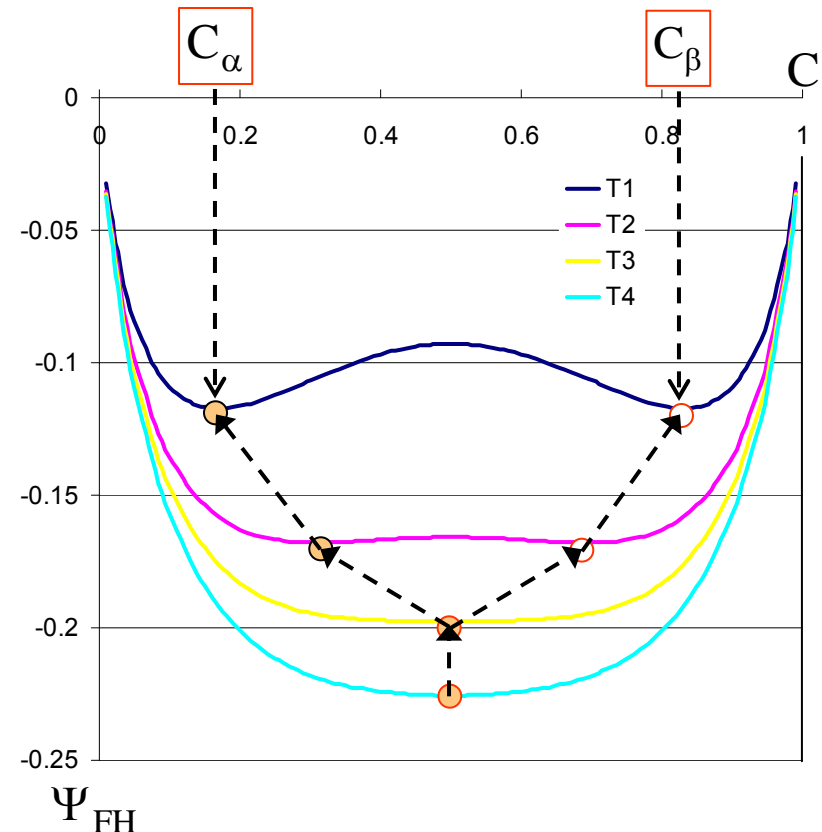
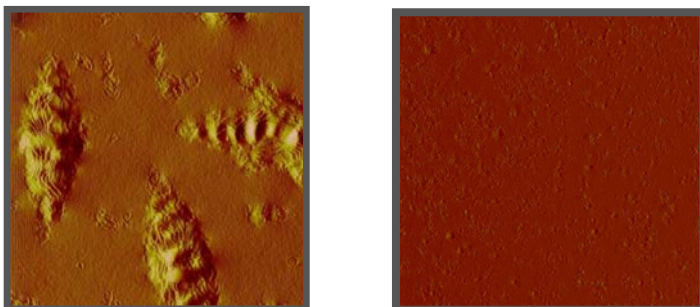

• Mixing theory

Governing equation:

$$\underline{\underline{M}} = \sum_{i,j} M_{ij} \mathbf{e}_i \otimes \mathbf{e}_j$$

$$\rho_\alpha \frac{DC_\alpha}{Dt} - \text{div}(\rho_\alpha \underline{\underline{M}} \cdot \nabla \mu_\alpha) = 0$$

$$\nabla \mu_\alpha = \nabla \left(\frac{\delta \Psi}{\delta C_\alpha} \right)$$

$$\Psi = \Psi_{\text{FH}} + \Psi_\gamma + \Psi_\varepsilon + \dots$$

surface

mechanical

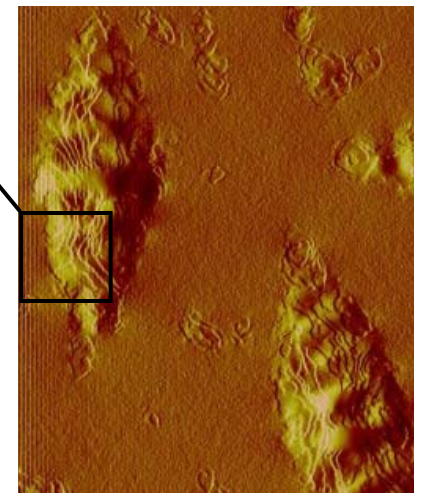
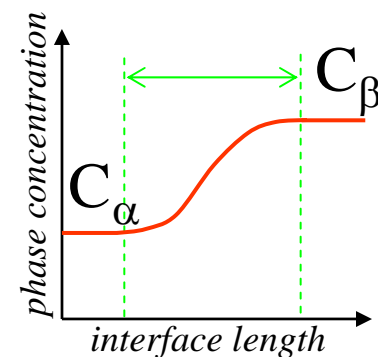
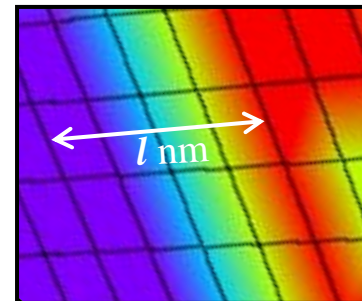

- **Mixing theory**

**Finite element
formulation:**

$$\int_{\mathbb{V}} w_i \rho_\alpha \frac{DC_\alpha}{Dt} dV + \int_{\mathbb{V}} \nabla w_i \rho_\alpha \underset{\approx}{M} \left(\frac{\partial^2 \Psi}{\partial C_\alpha^2} + \kappa \right) \nabla C_\alpha dV - \int_{\mathbb{V}} \nabla w_i \rho_\alpha \underset{\approx}{M} \kappa \nabla \bar{C}_\alpha dV = 0$$

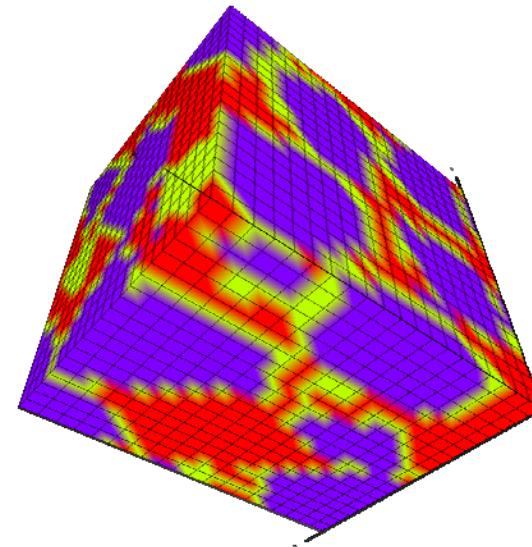
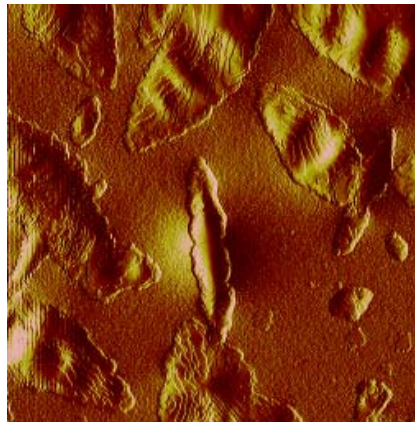

• Mixing theory

INPUT PARAMETER	Value
Gas constant R	8.314472 J/K · mol
Temperature T	273.14 + T(°C)
Molecular volume V_α	e.g. 636 ml/mol
Solubility of δ_α and δ_β of two phases to compute the interaction parameter $X = \frac{V_\alpha}{RT} (\delta_\beta - \delta_\alpha)^2$	e.g. $\delta_\alpha = 14$ and $\delta = 17$
M_{ij}	e.g. $M_{ij}\delta_{ij}$ and $M_{11} = M_{22} = M_{33}$
λ from $\bar{c} = c + \lambda^2 \nabla \cdot \nabla c$	From calibration
κ_2 from which $\kappa = -\frac{\kappa_2}{\lambda^2}$	From calibration

...asphalt under the Atomic Force Microscope

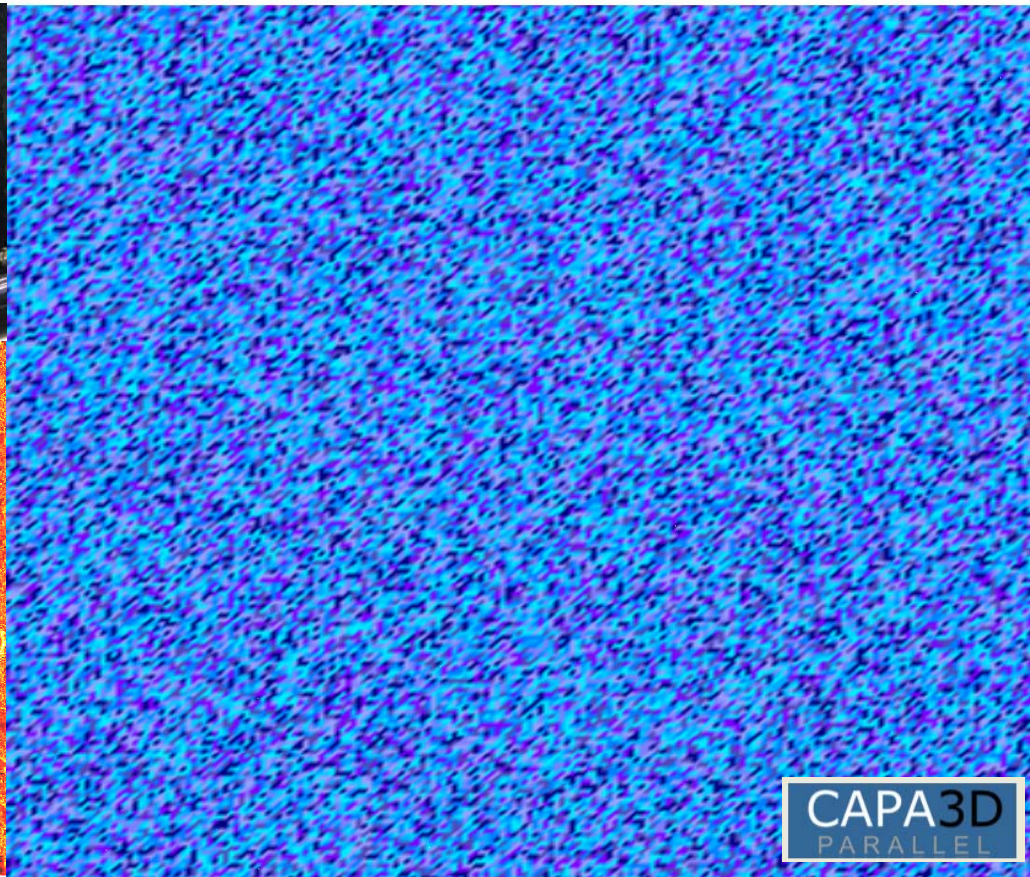
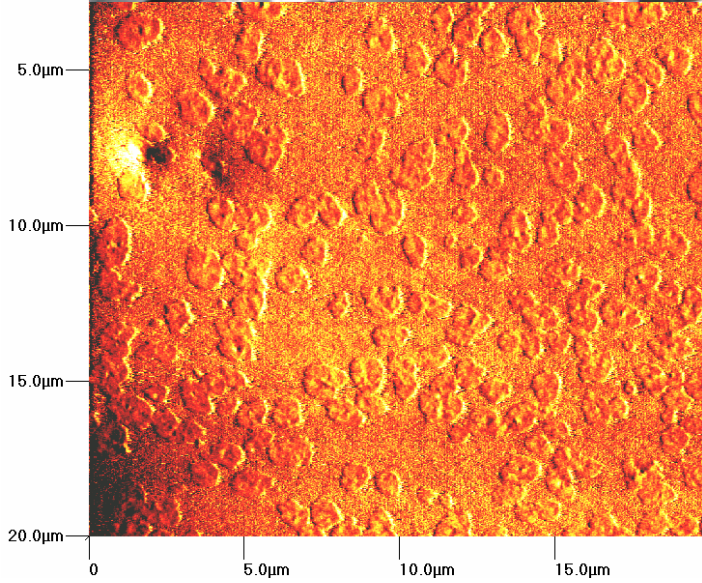
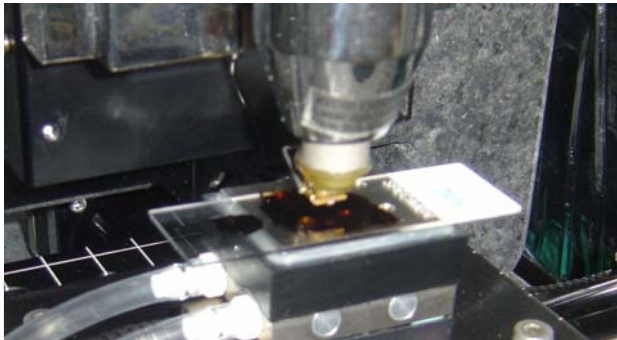
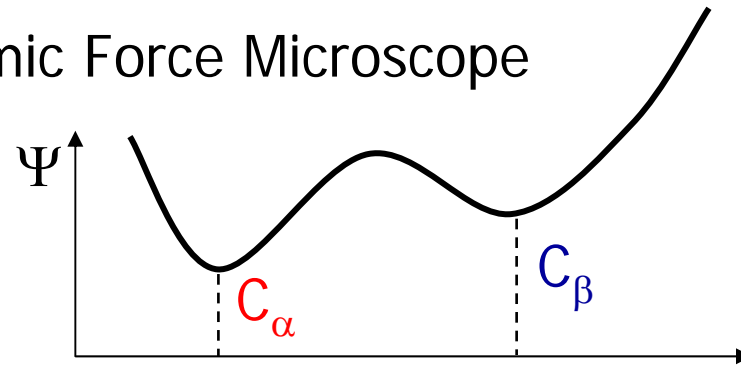
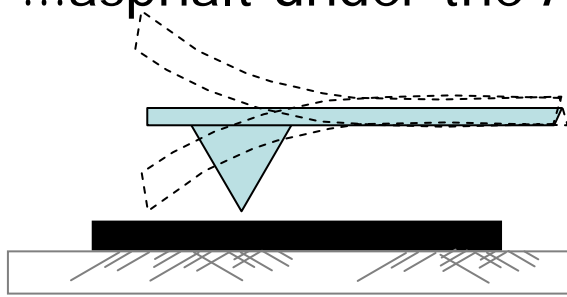

...asphalt under the Atomic Force Microscope

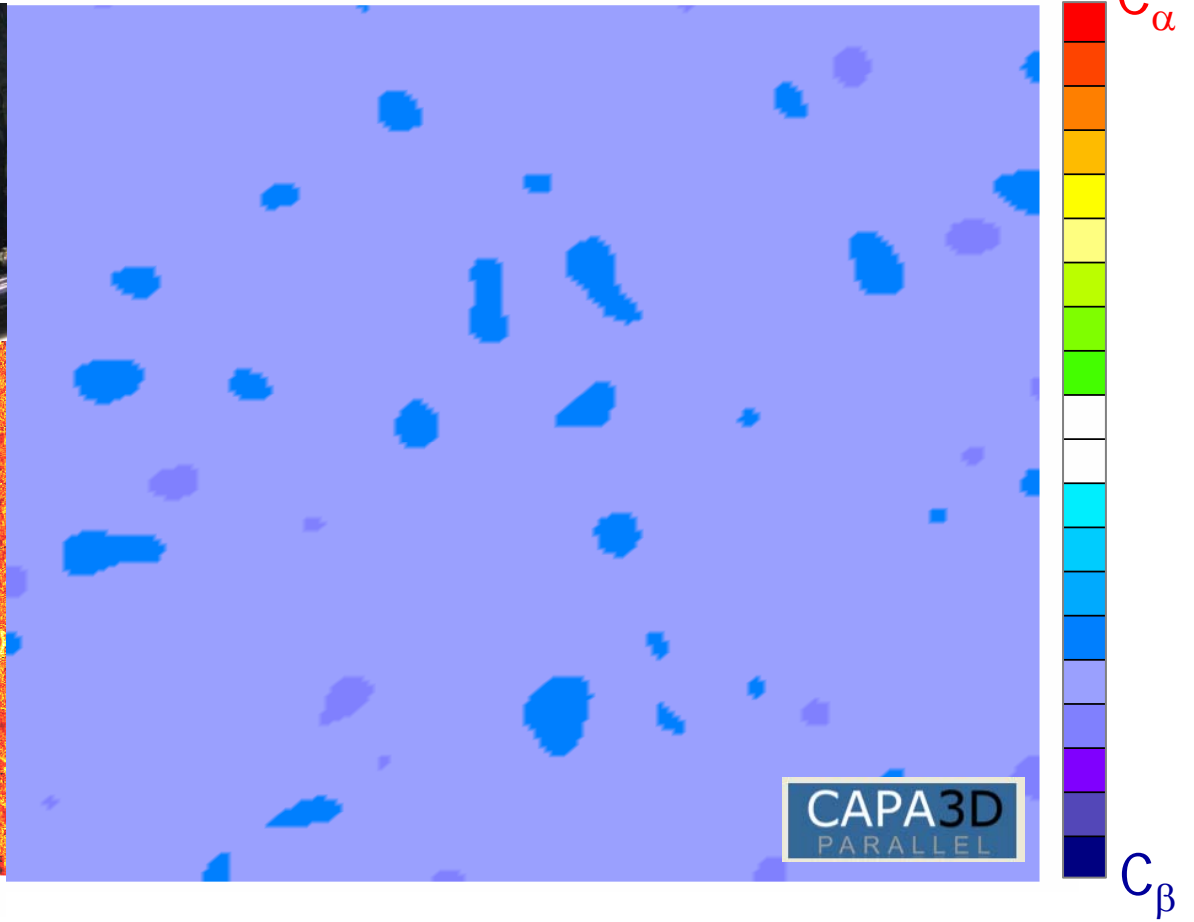
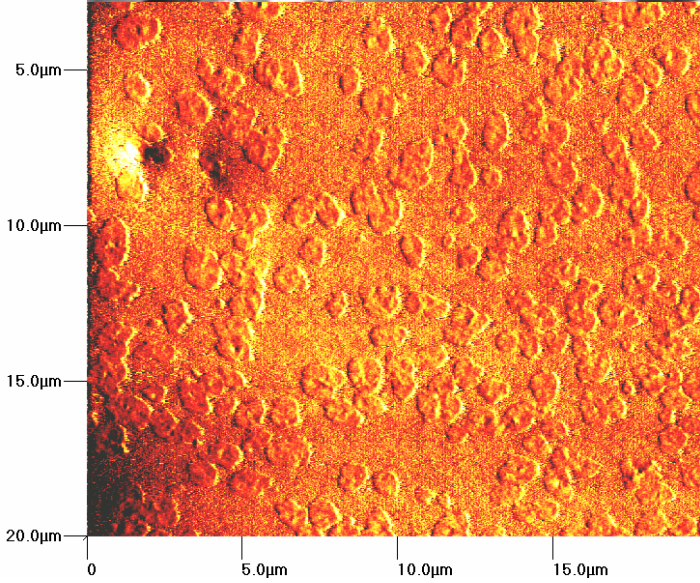
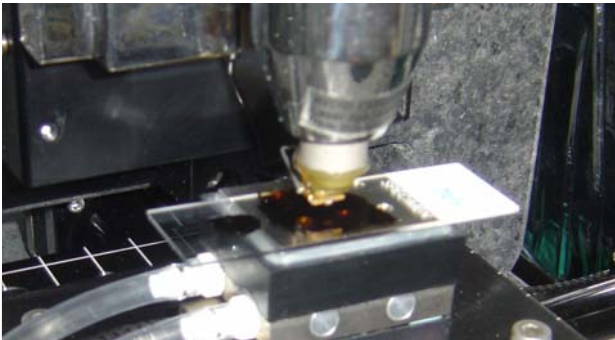
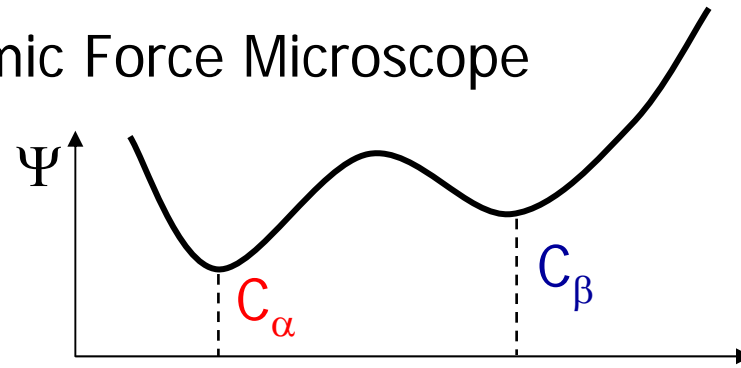
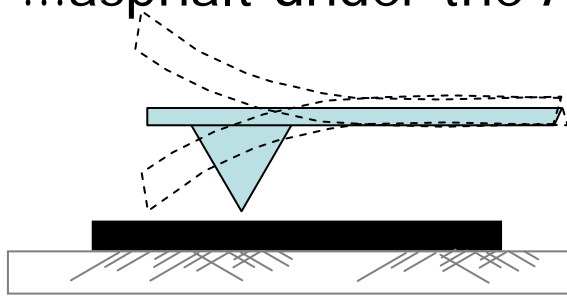

...asphalt under the Atomic Force Microscope

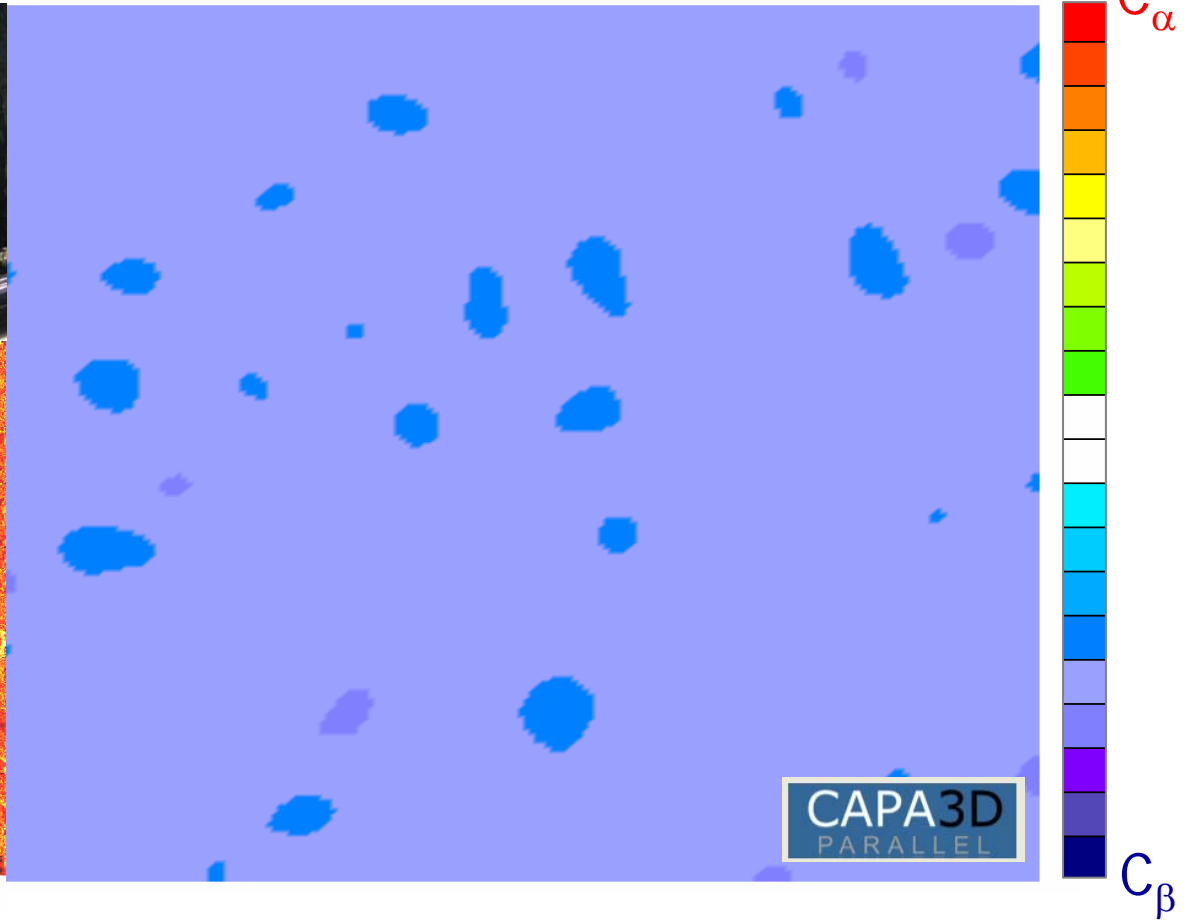
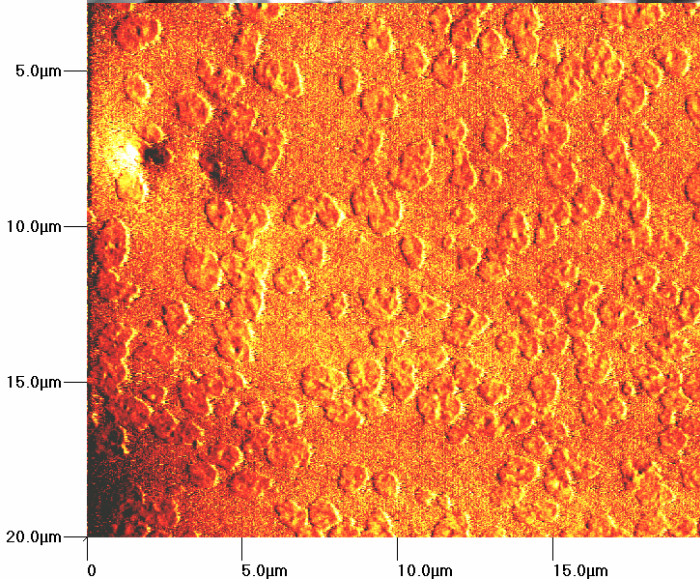
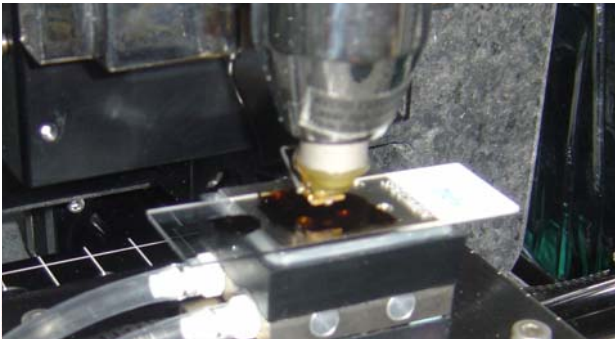
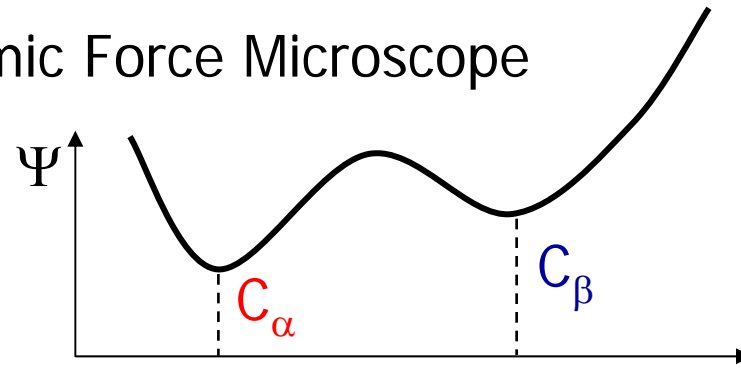
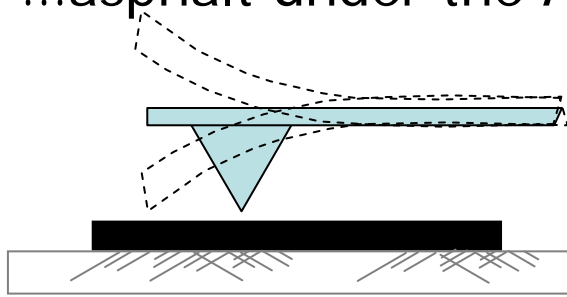

...asphalt under the Atomic Force Microscope

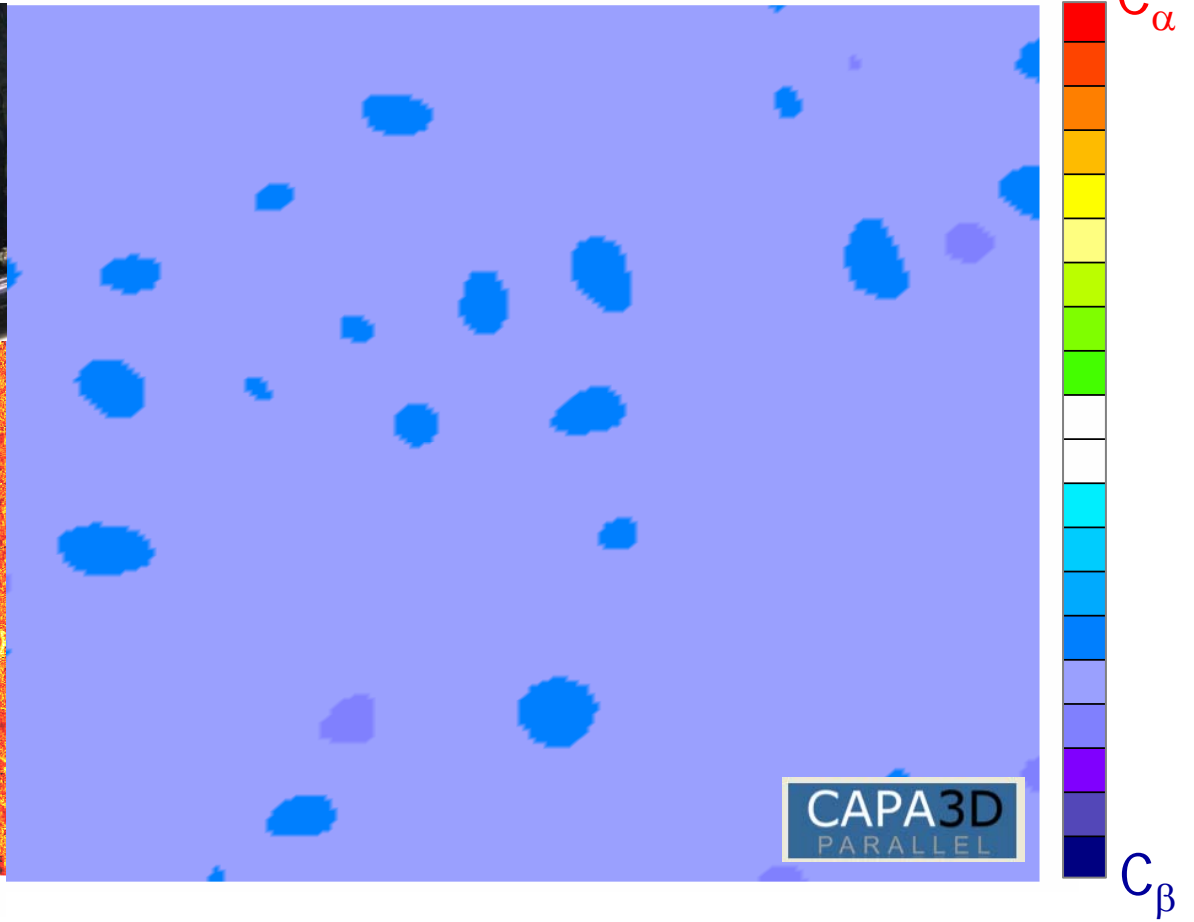
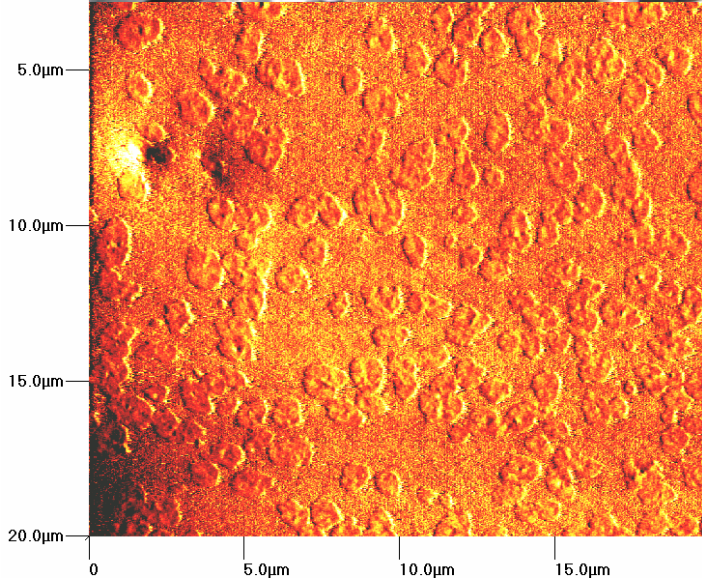
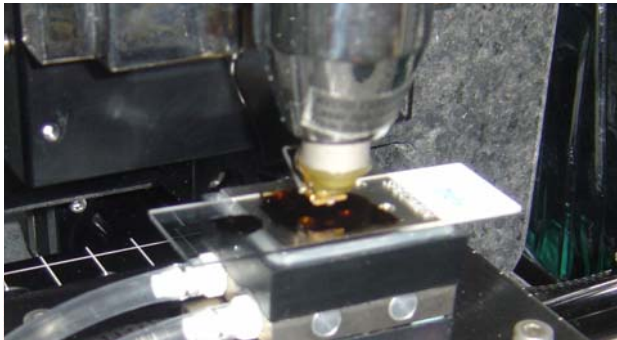
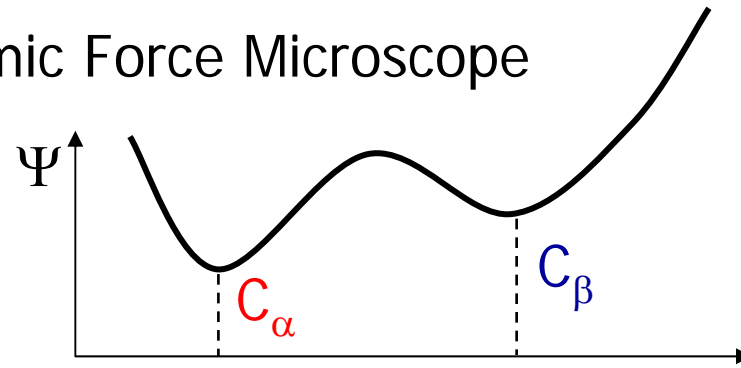
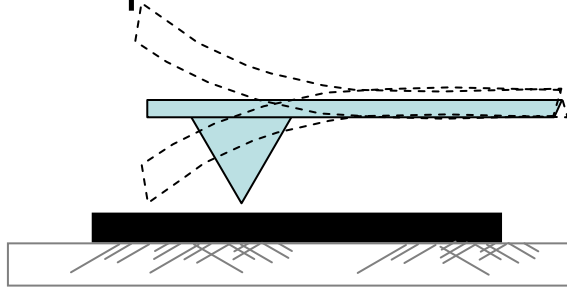

...asphalt under the Atomic Force Microscope

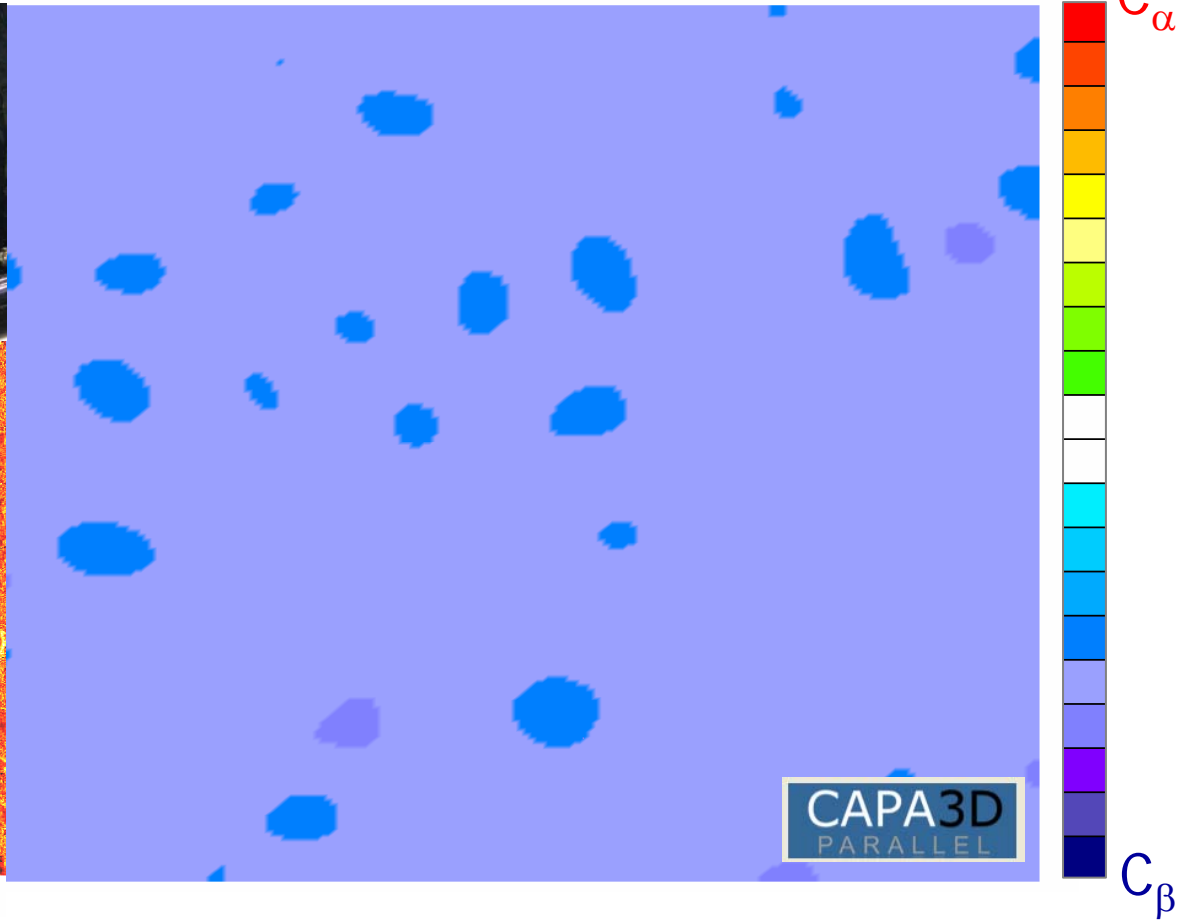
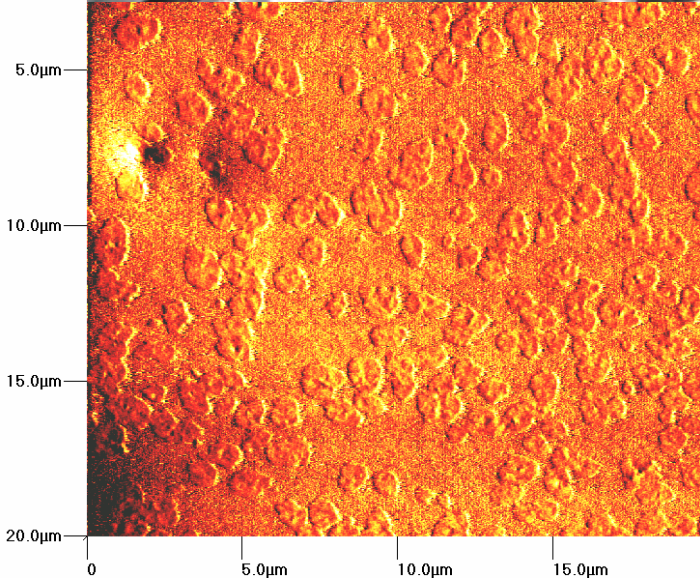
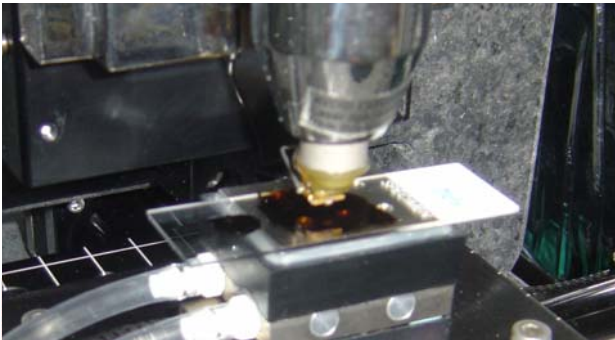
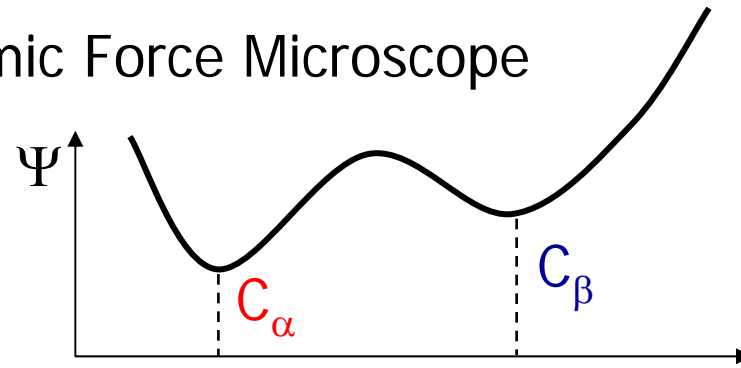
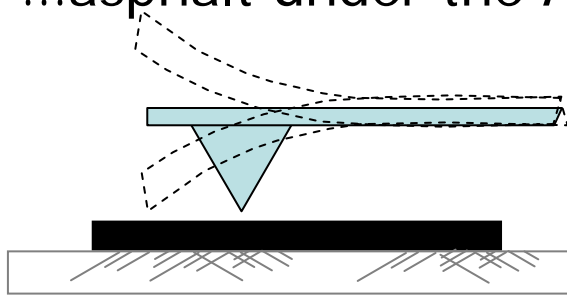

...asphalt under the Atomic Force Microscope

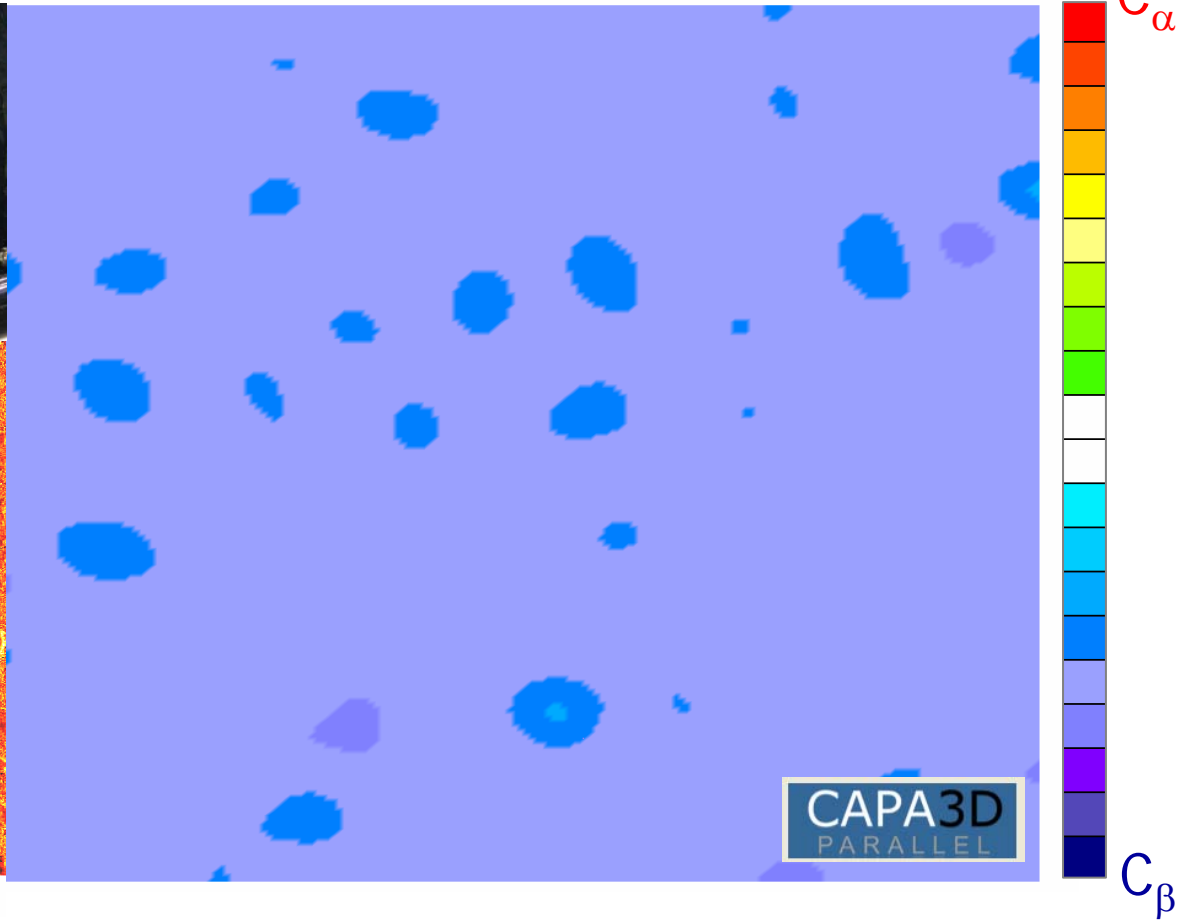
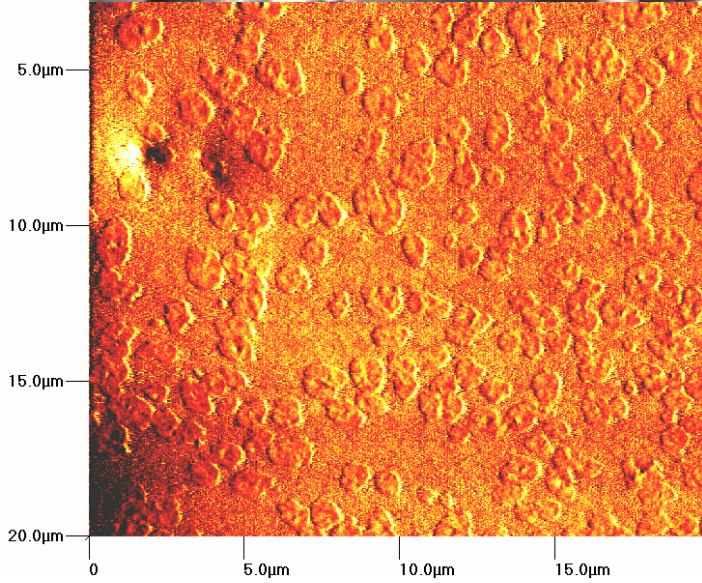
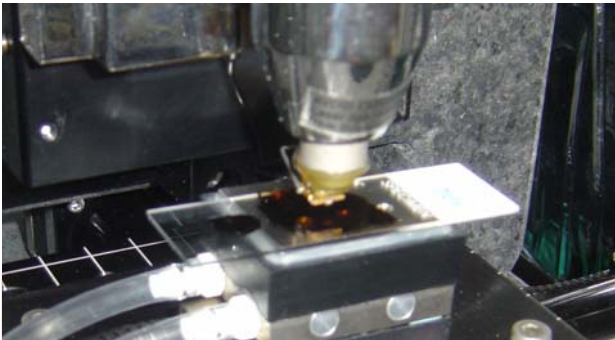
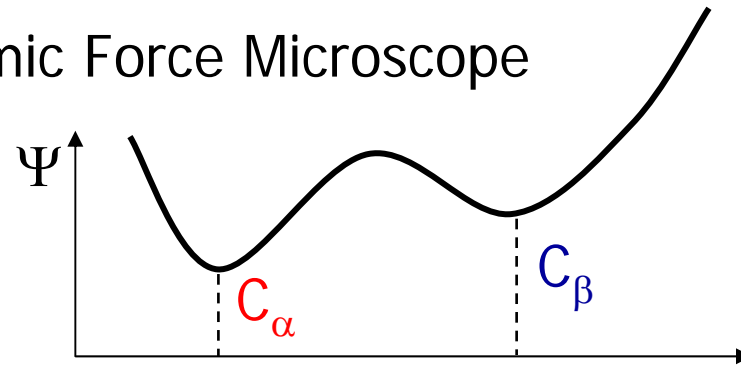
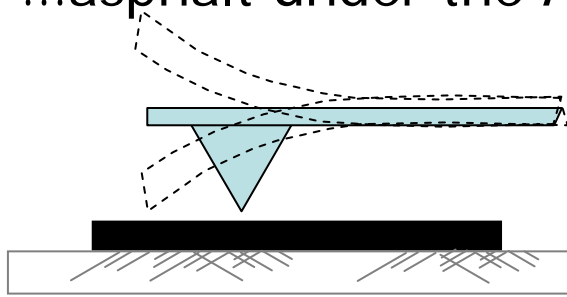

...asphalt under the Atomic Force Microscope

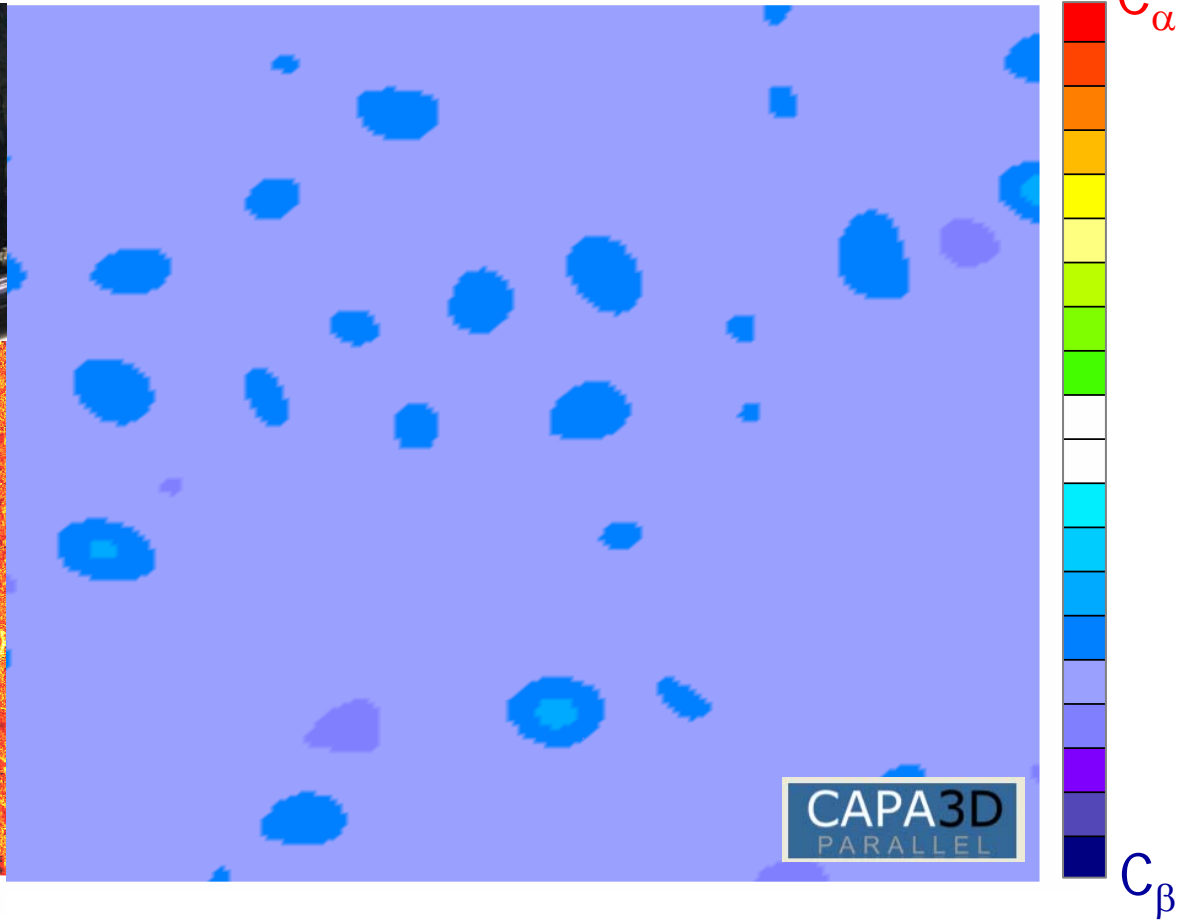
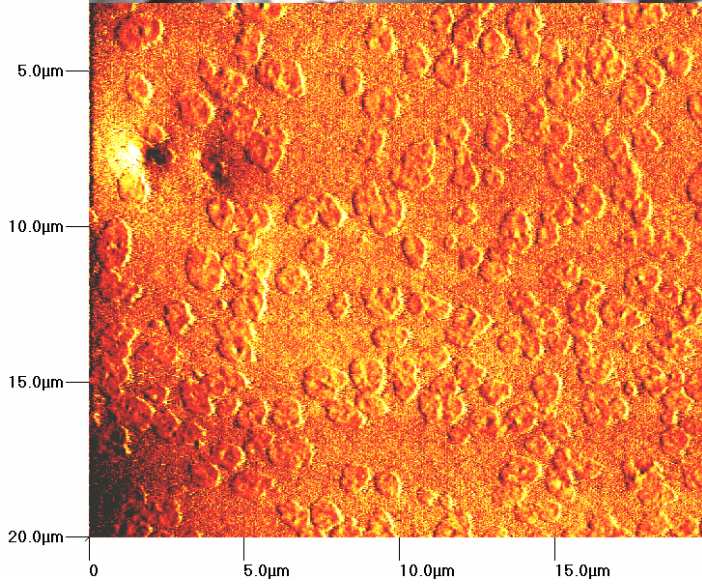
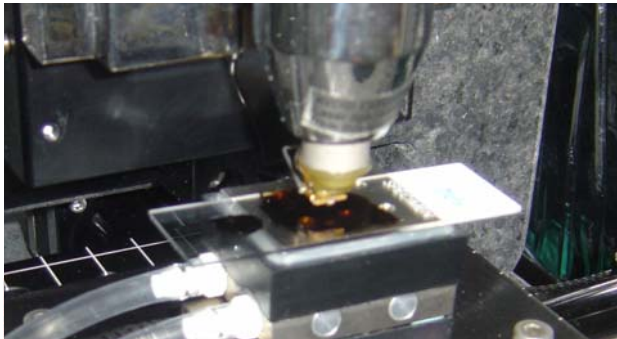
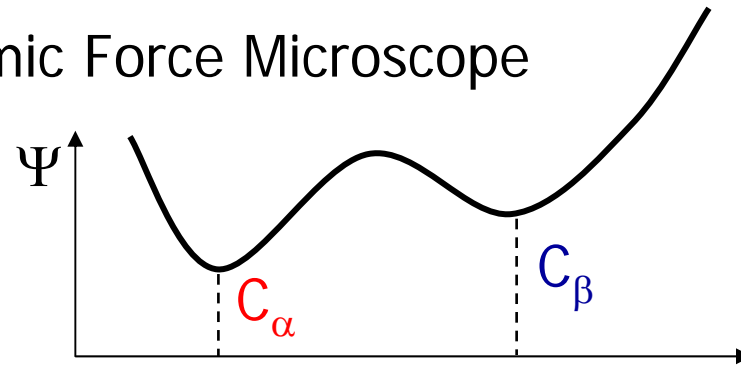
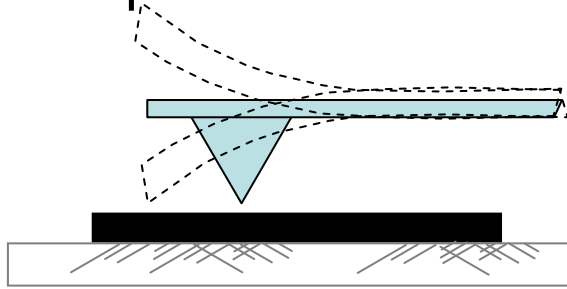

...asphalt under the Atomic Force Microscope

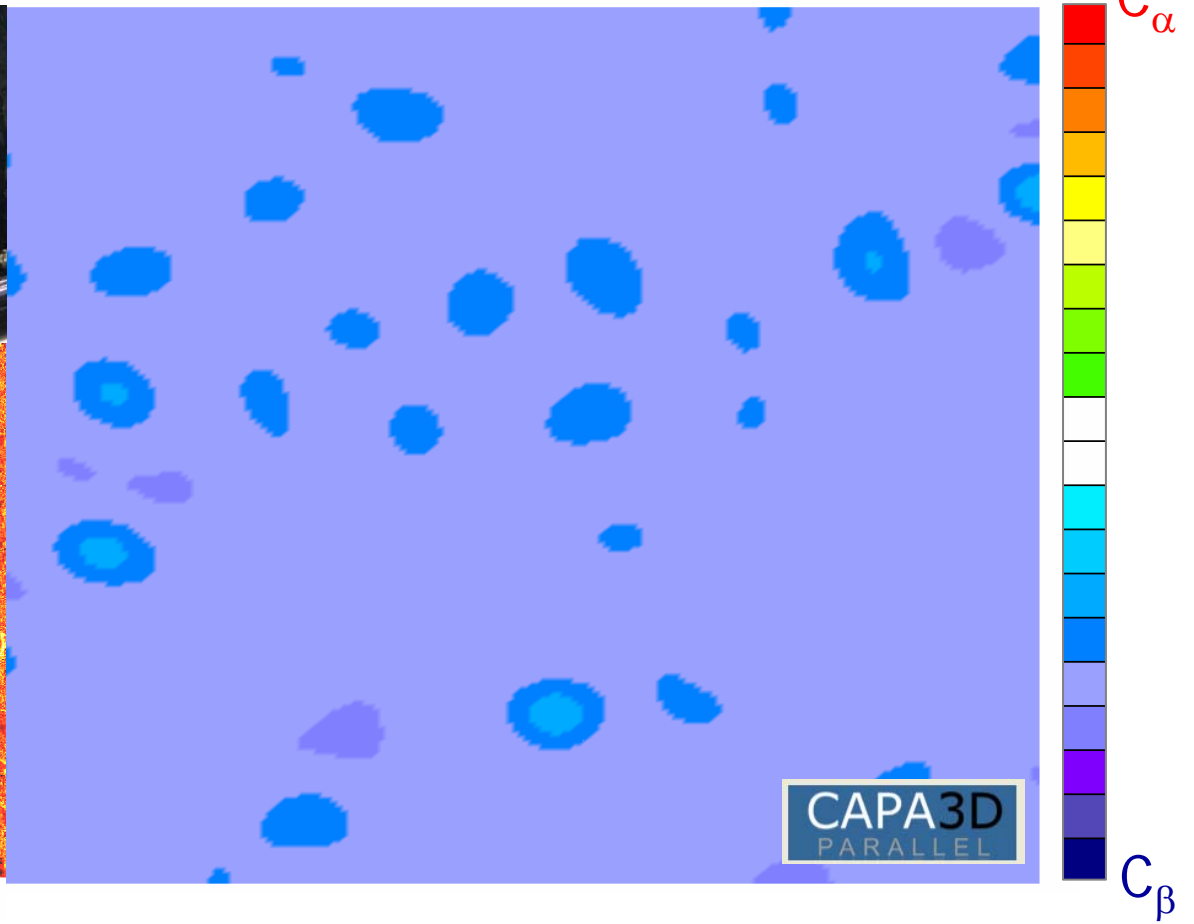
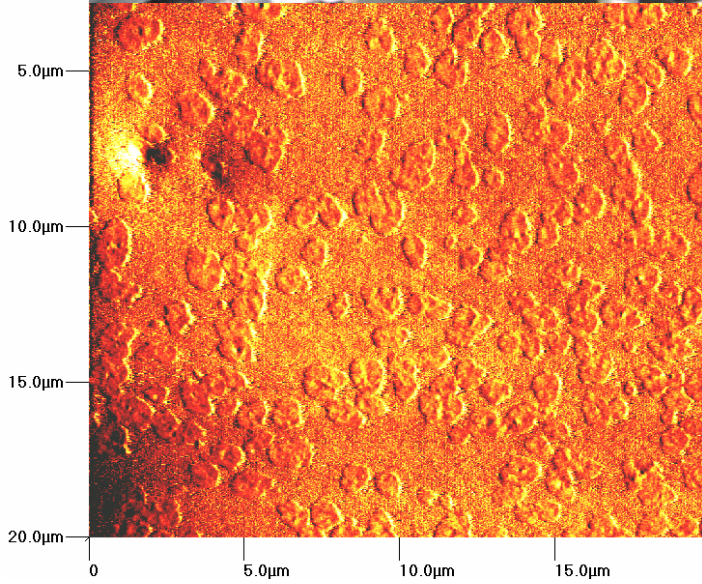
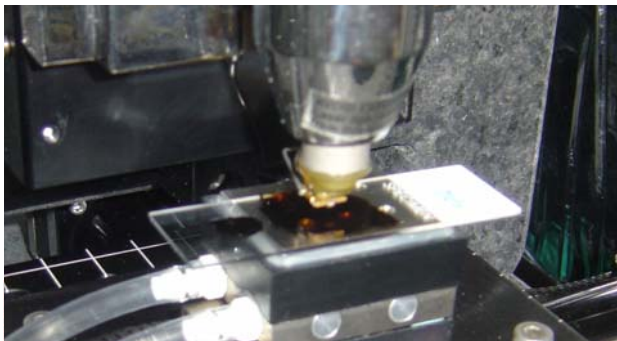
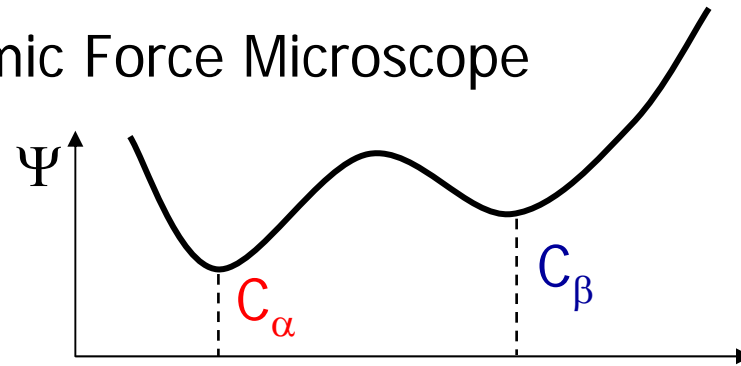
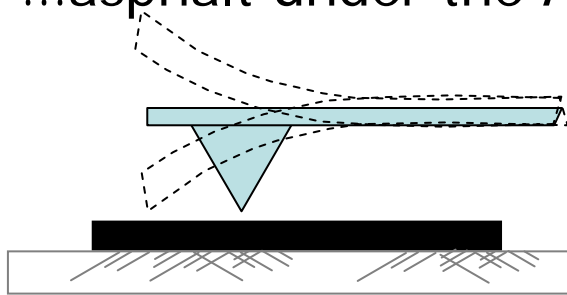

...asphalt under the Atomic Force Microscope

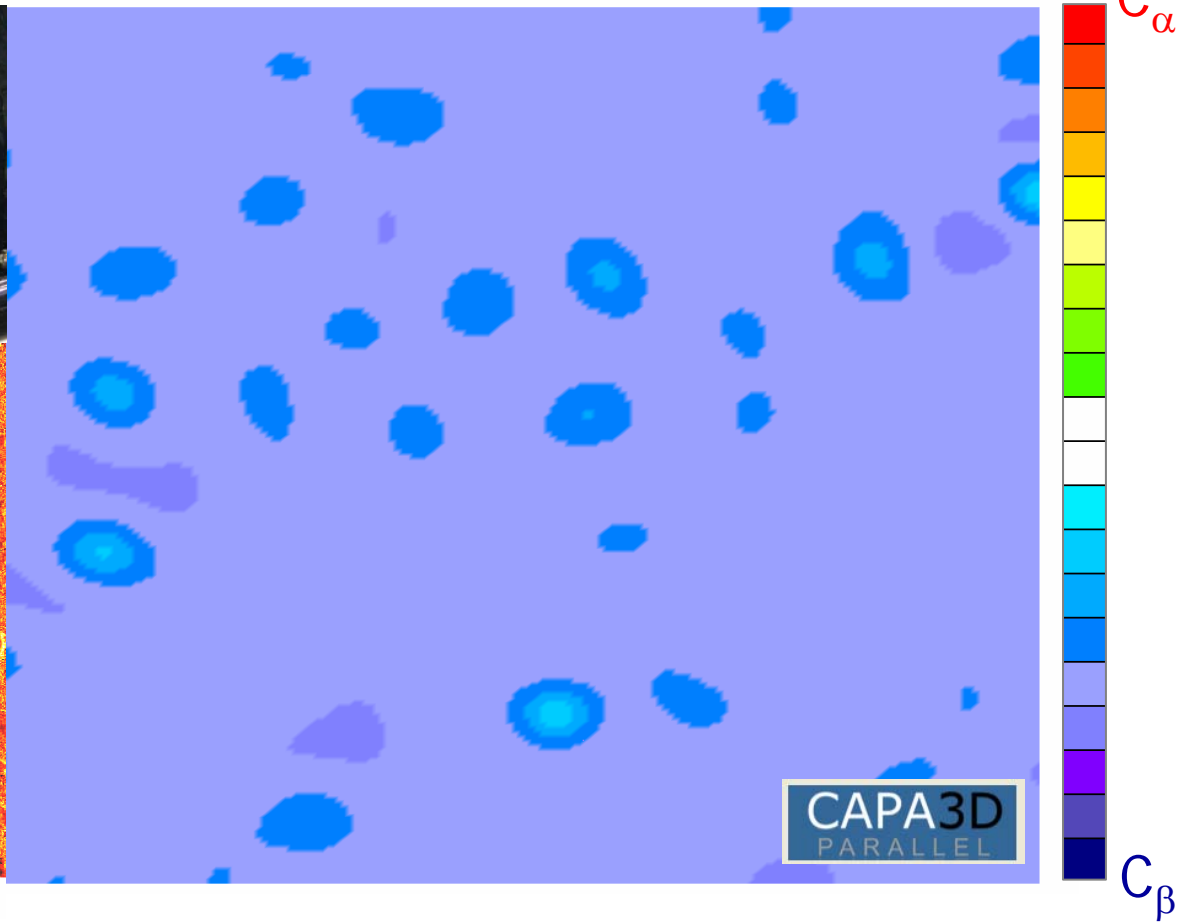
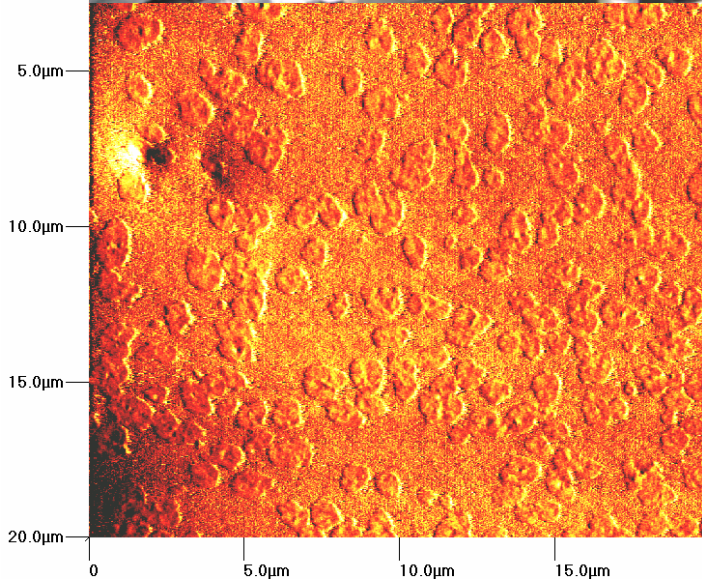
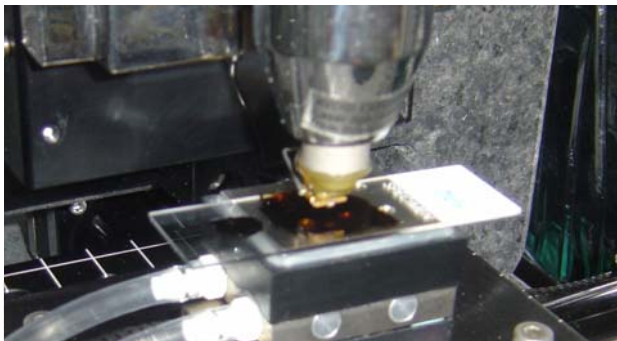
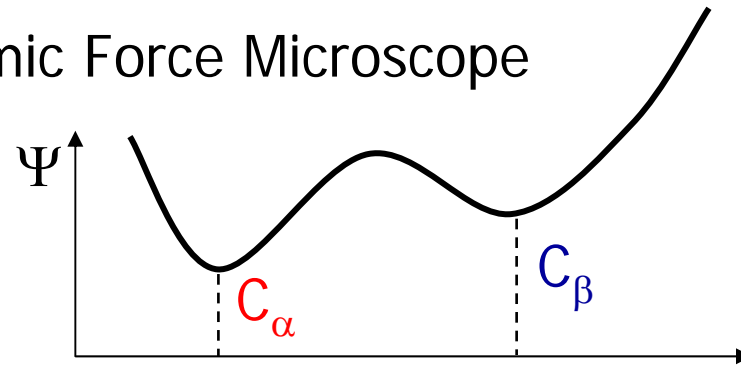
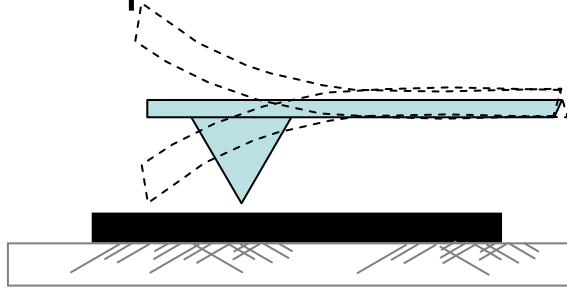

...asphalt under the Atomic Force Microscope

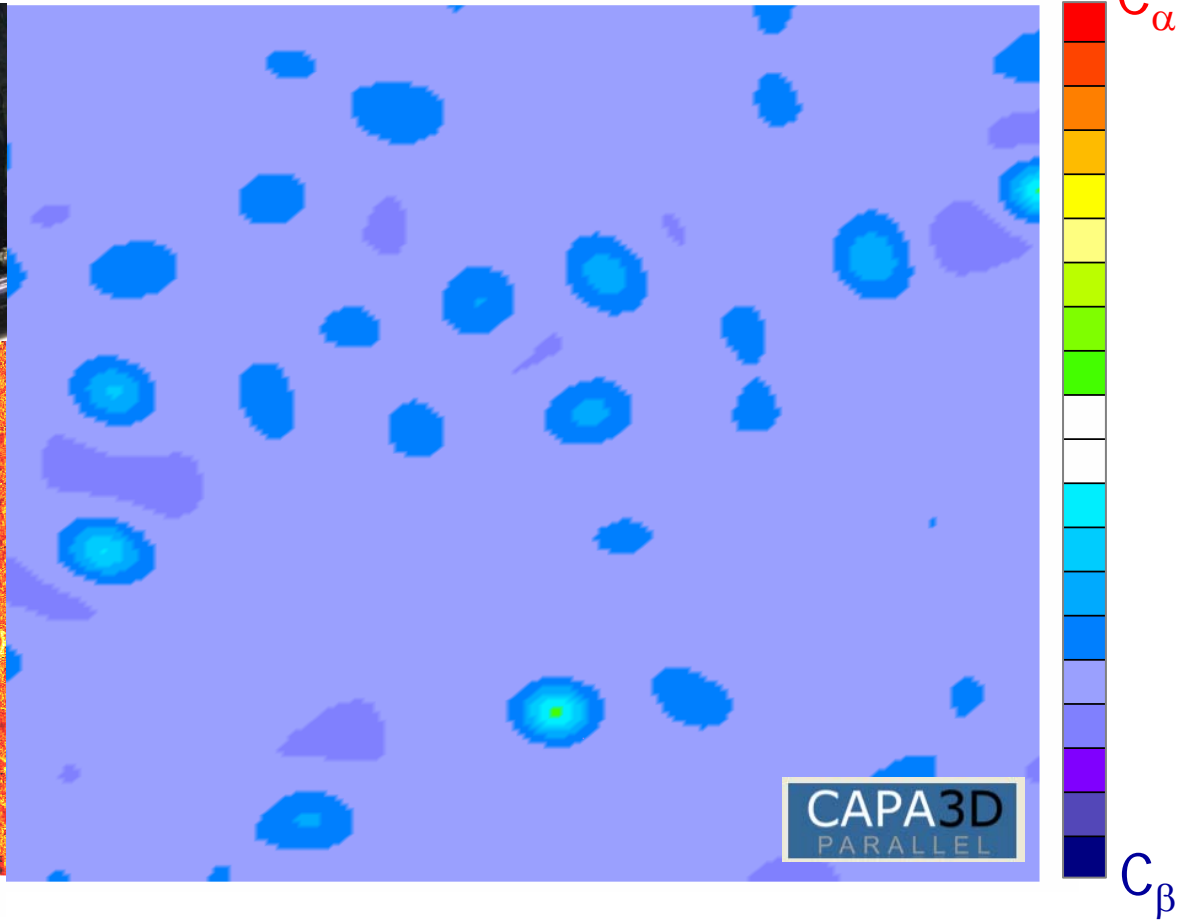
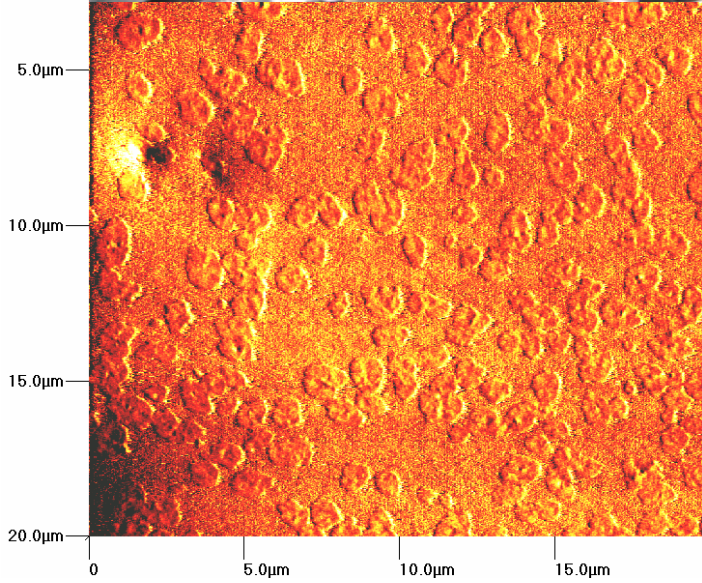
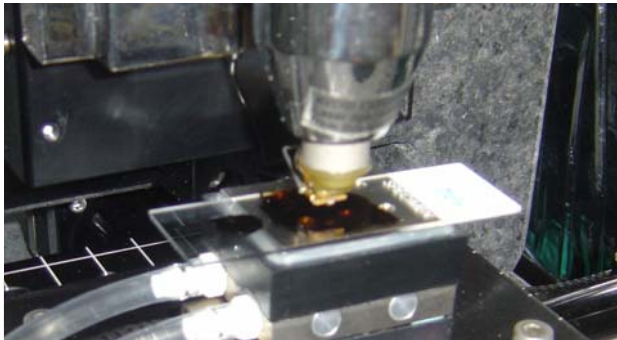
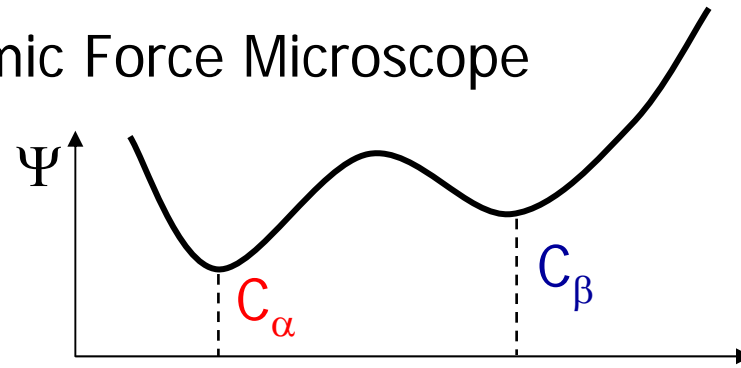
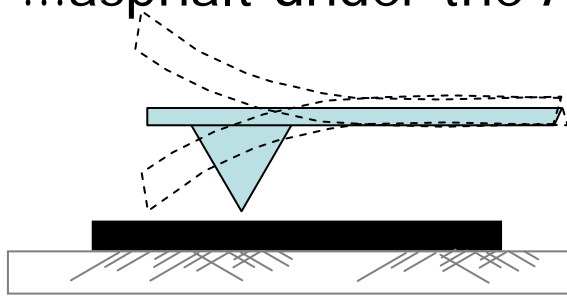

...asphalt under the Atomic Force Microscope

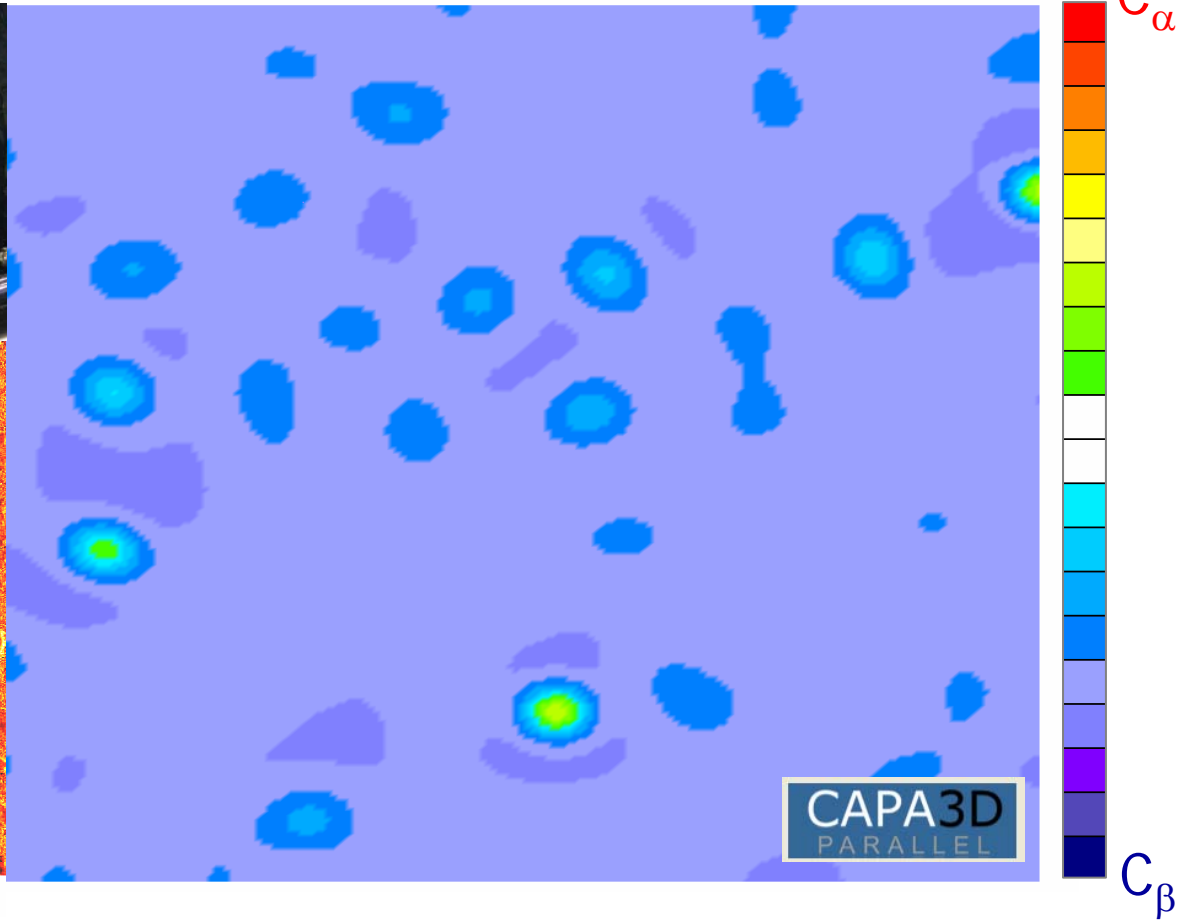
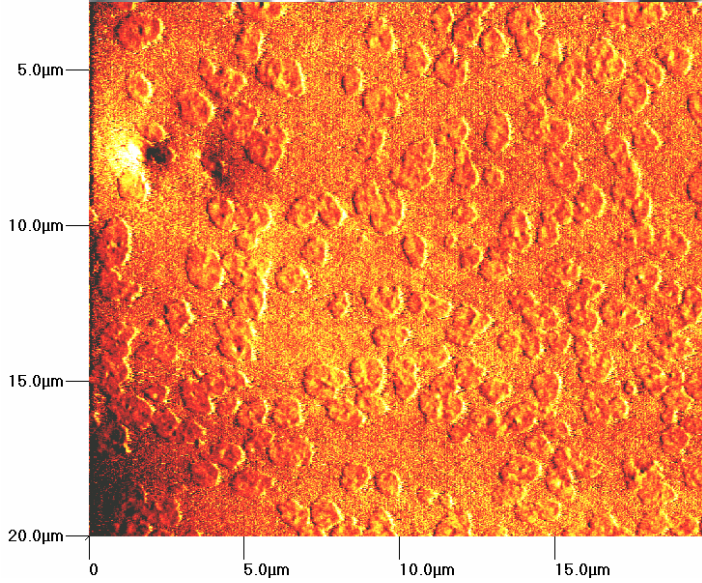
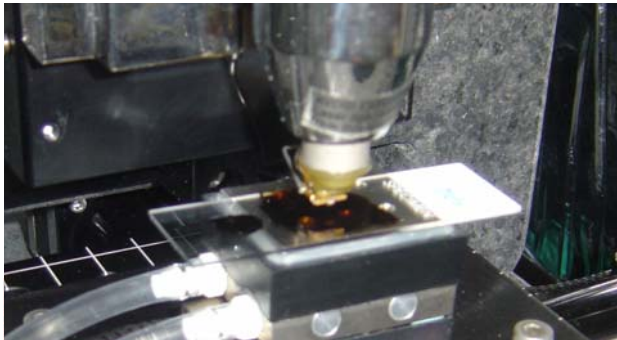
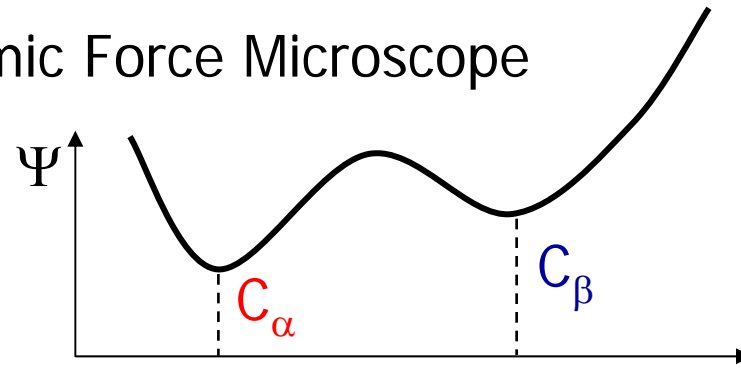
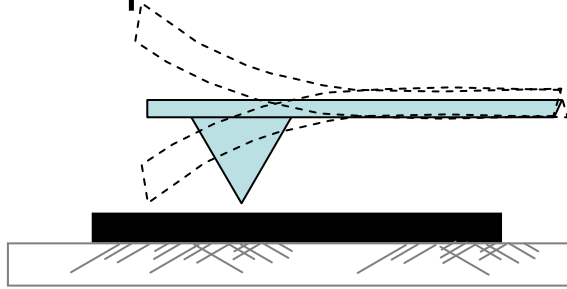

...asphalt under the Atomic Force Microscope

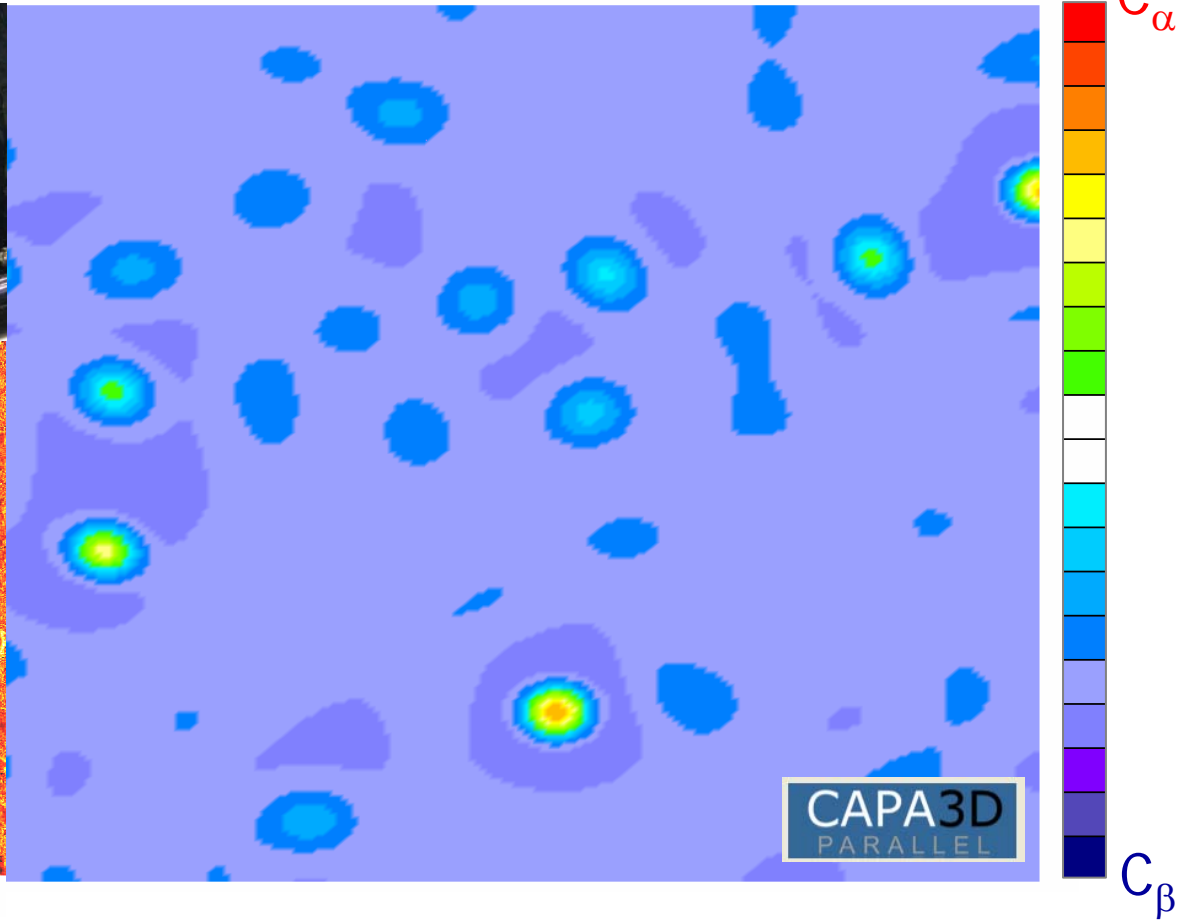
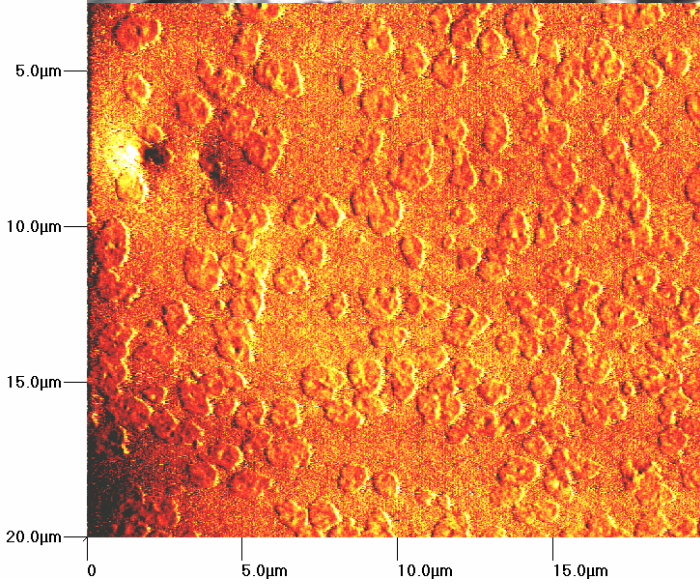
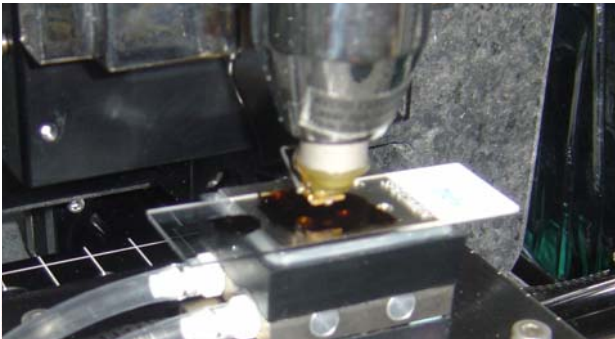
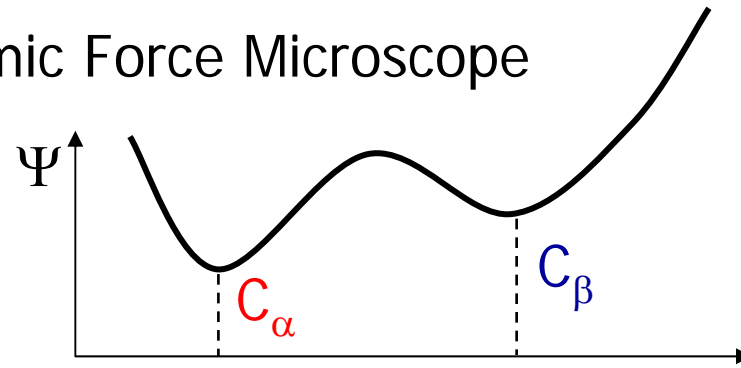
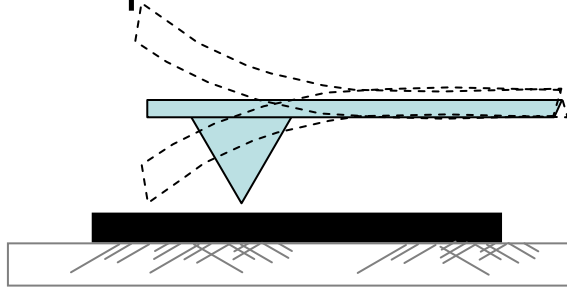

...asphalt under the Atomic Force Microscope

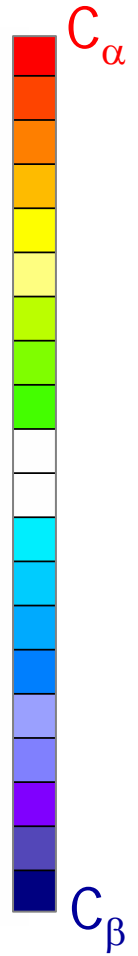
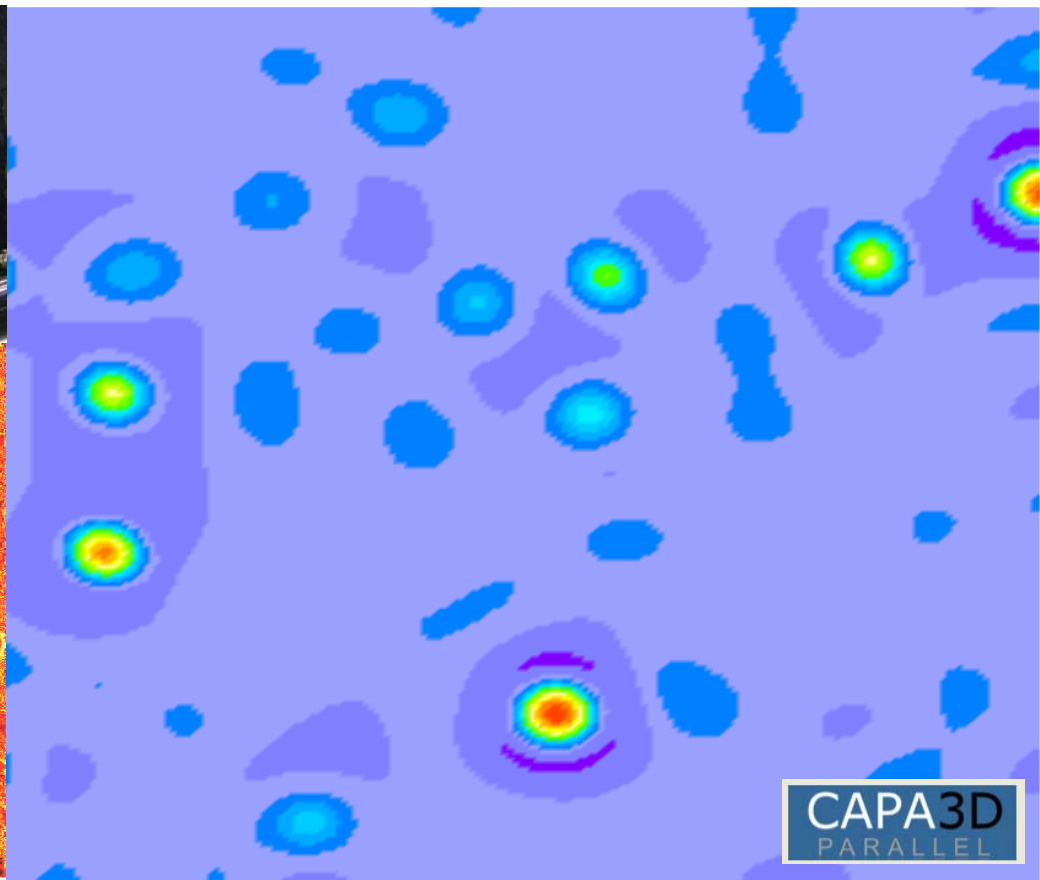
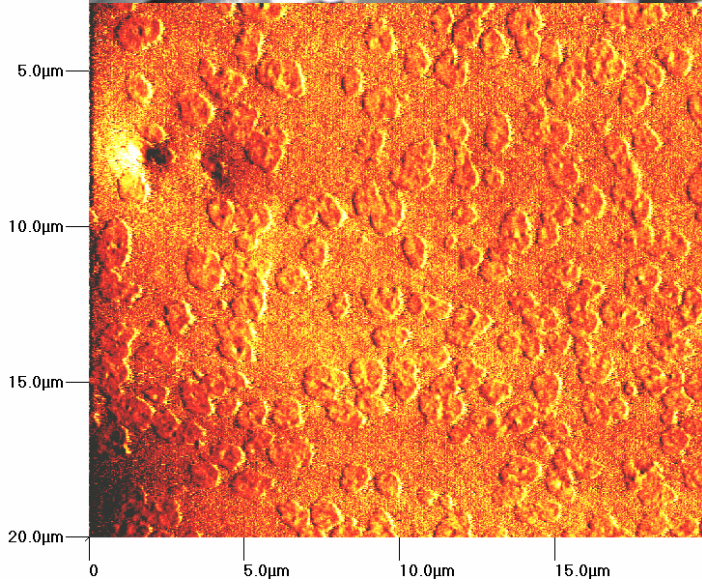
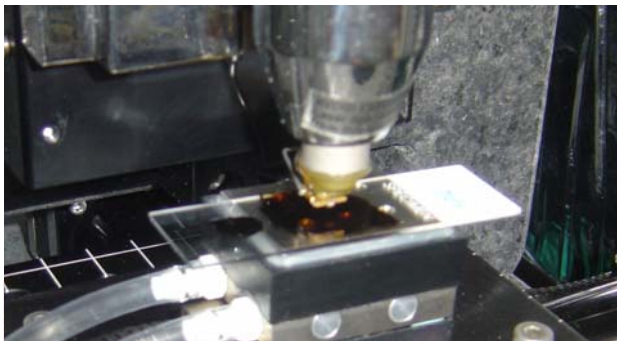
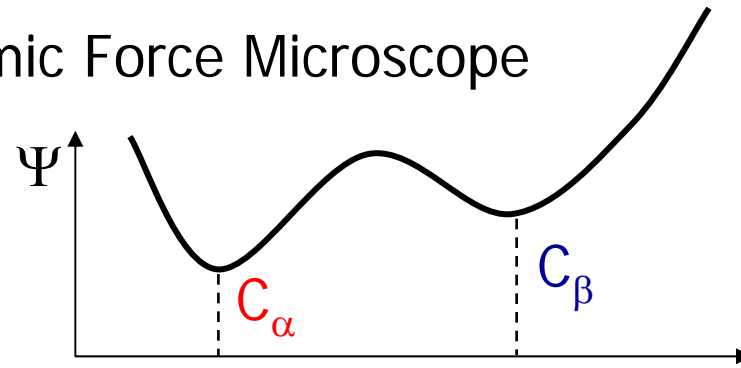
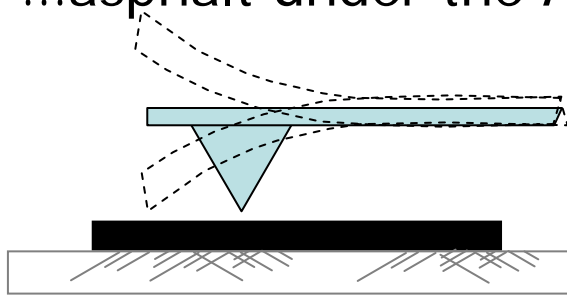

CAPA3D
PARALLEL

...asphalt under the Atomic Force Microscope

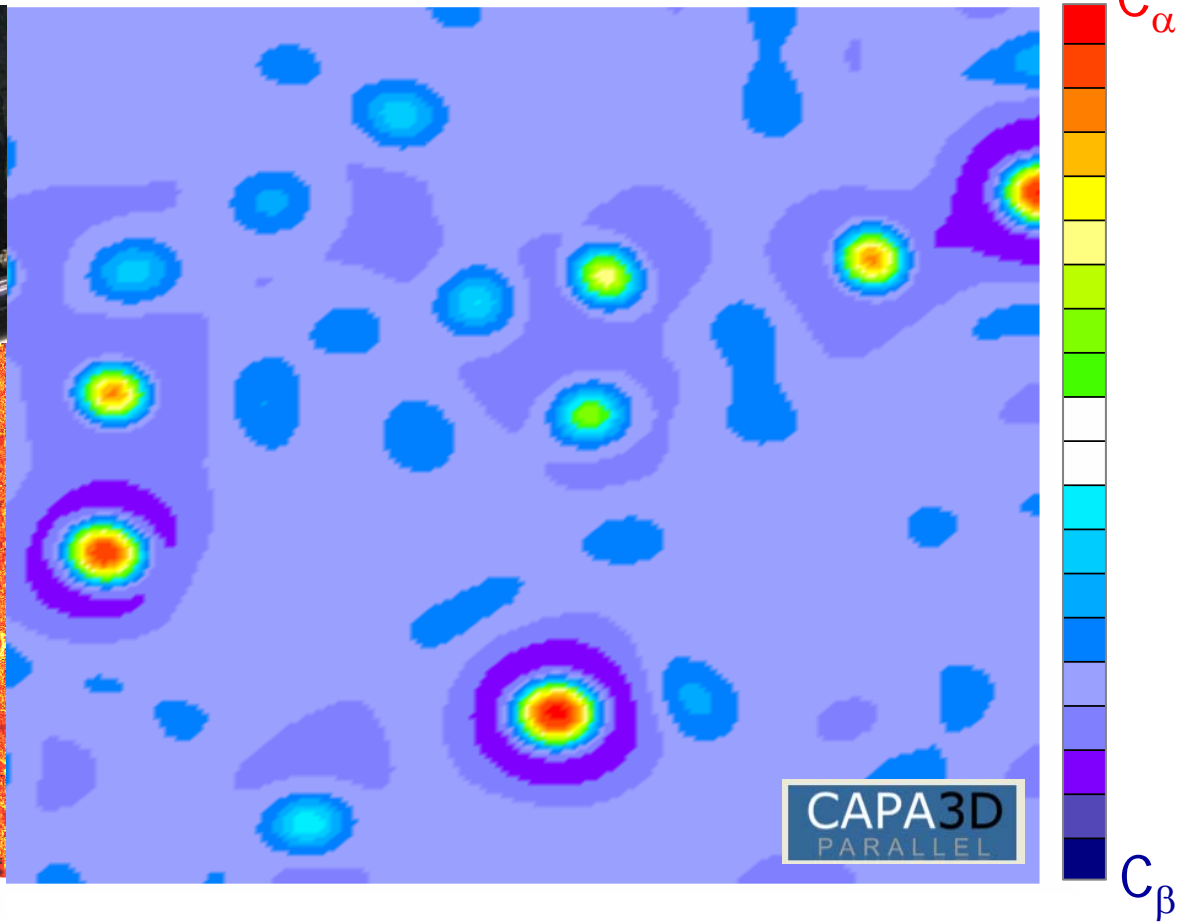
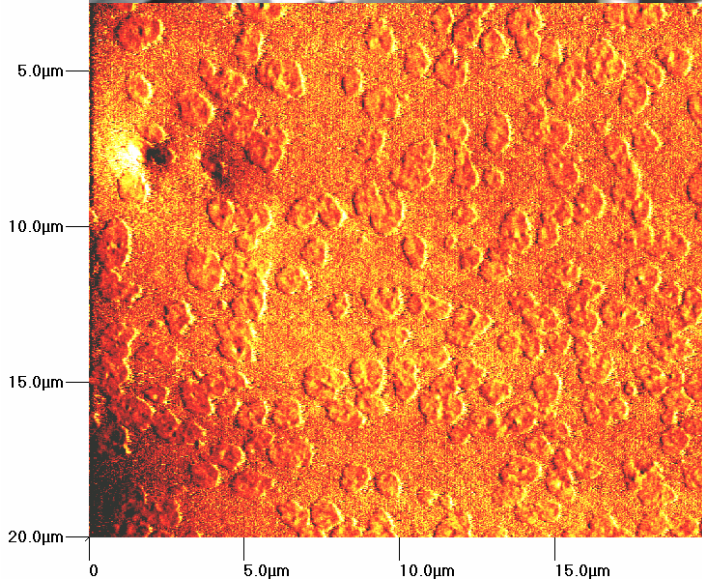
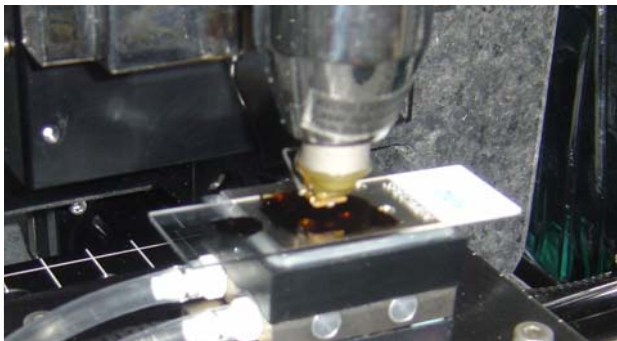
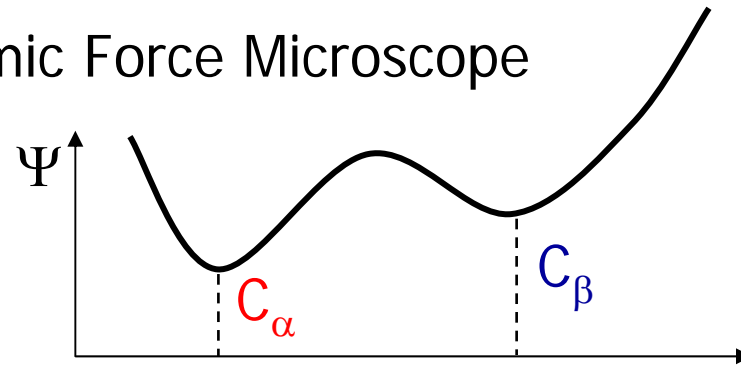
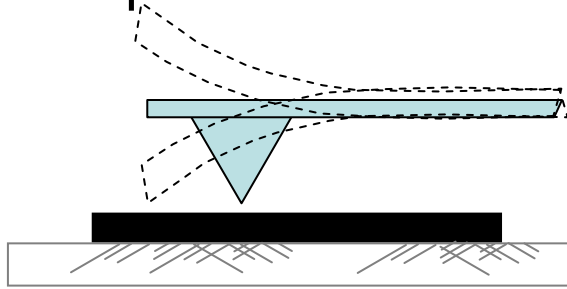

...asphalt under the Atomic Force Microscope

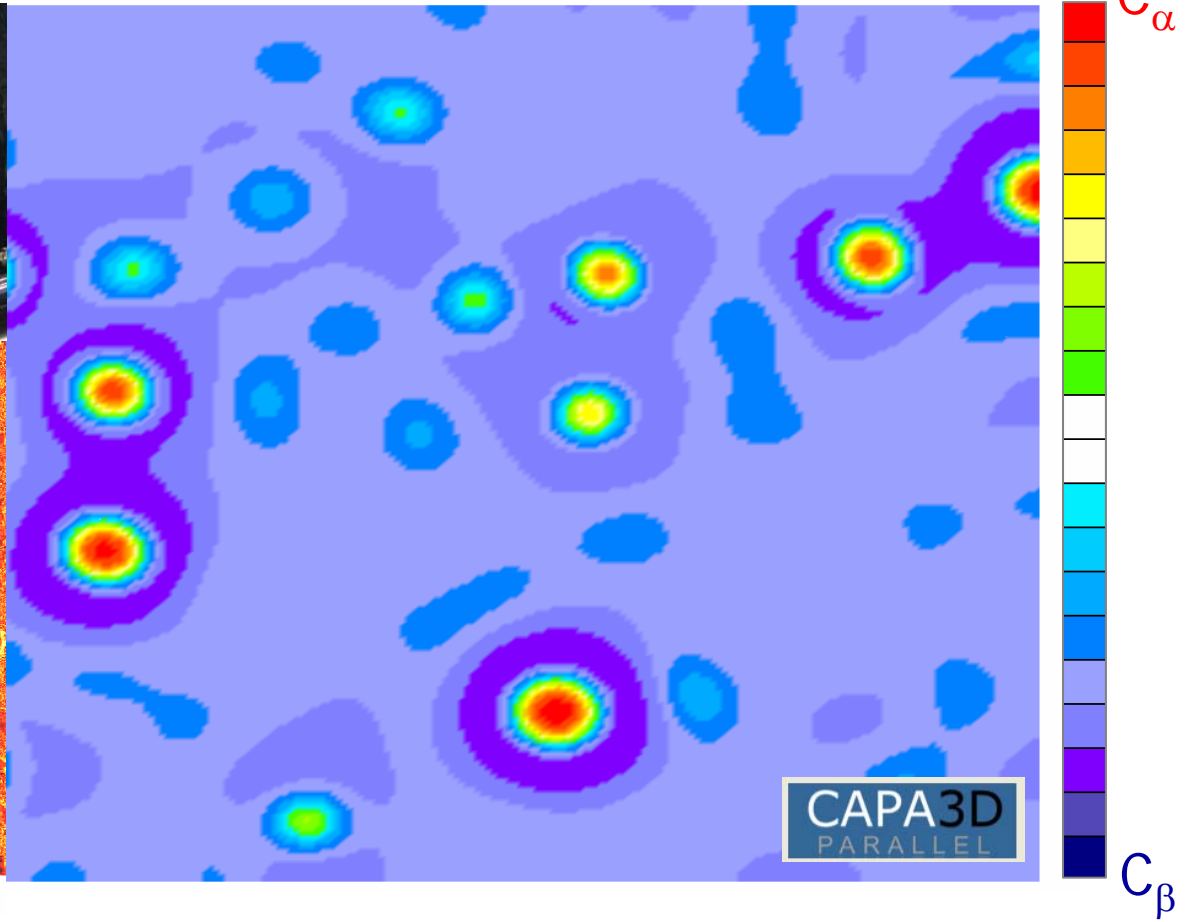
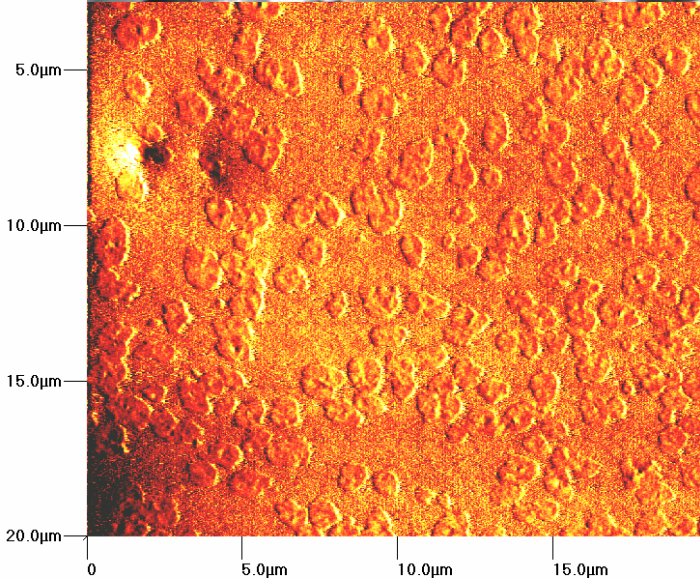
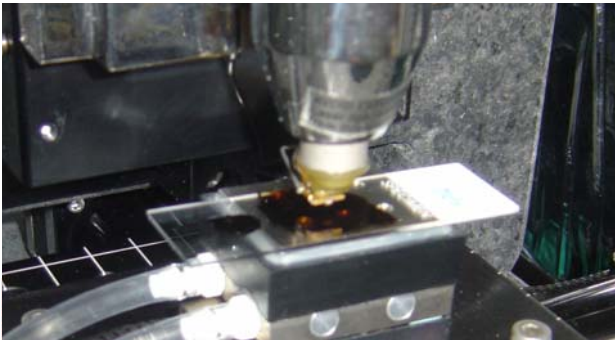
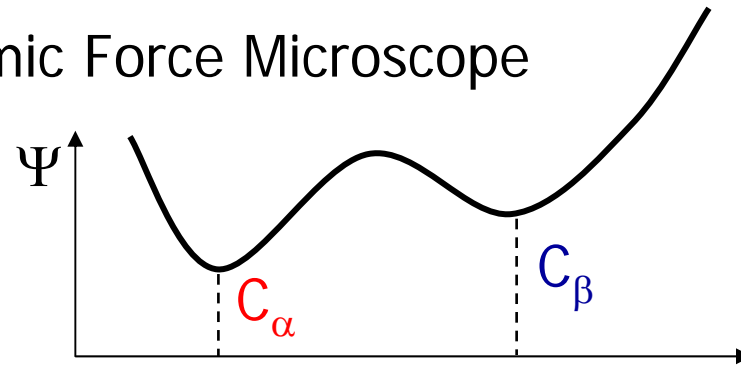
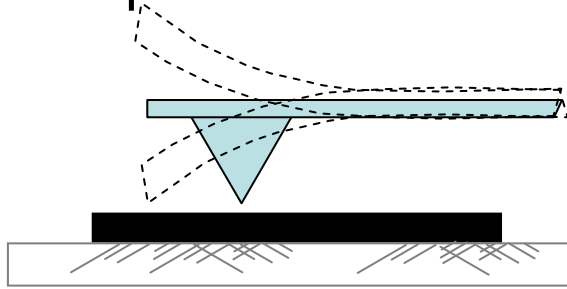

...asphalt under the Atomic Force Microscope

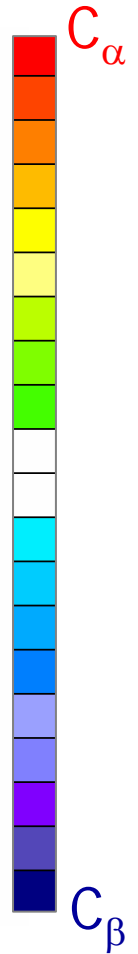
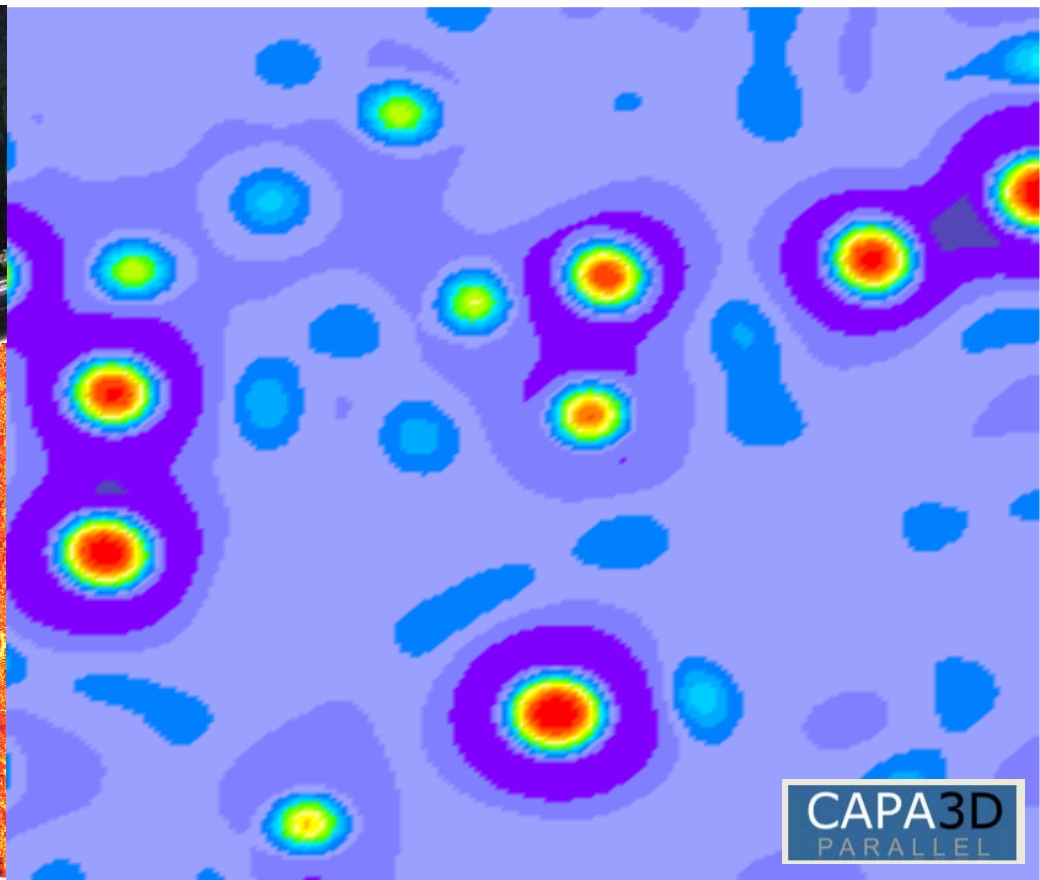
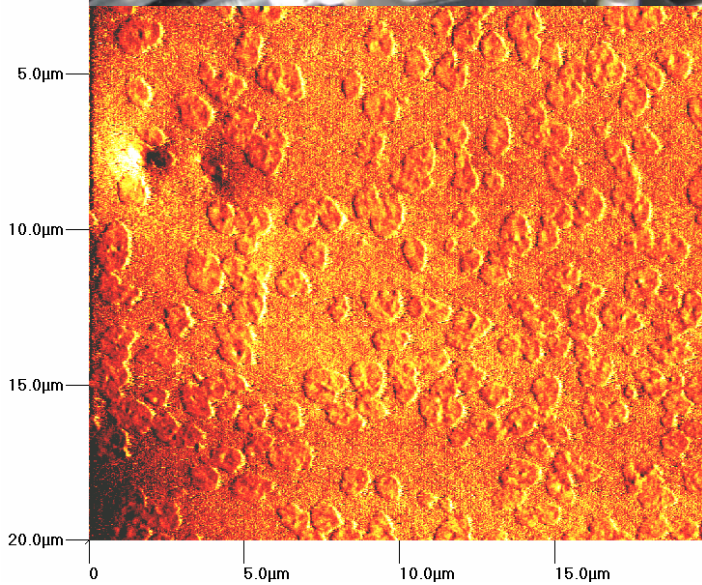
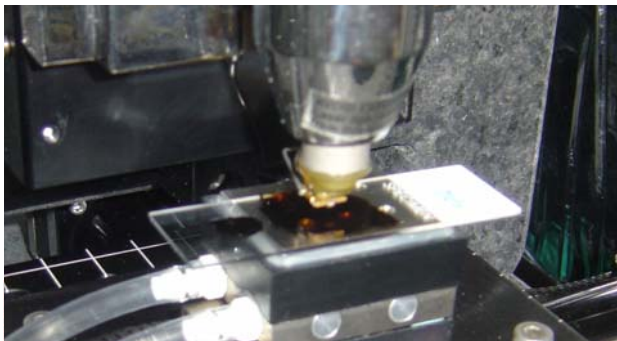
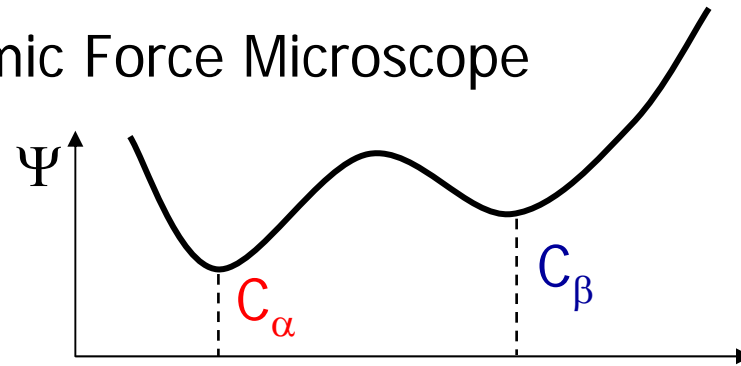
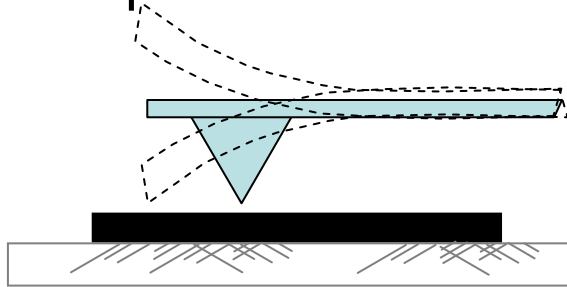

...asphalt under the Atomic Force Microscope

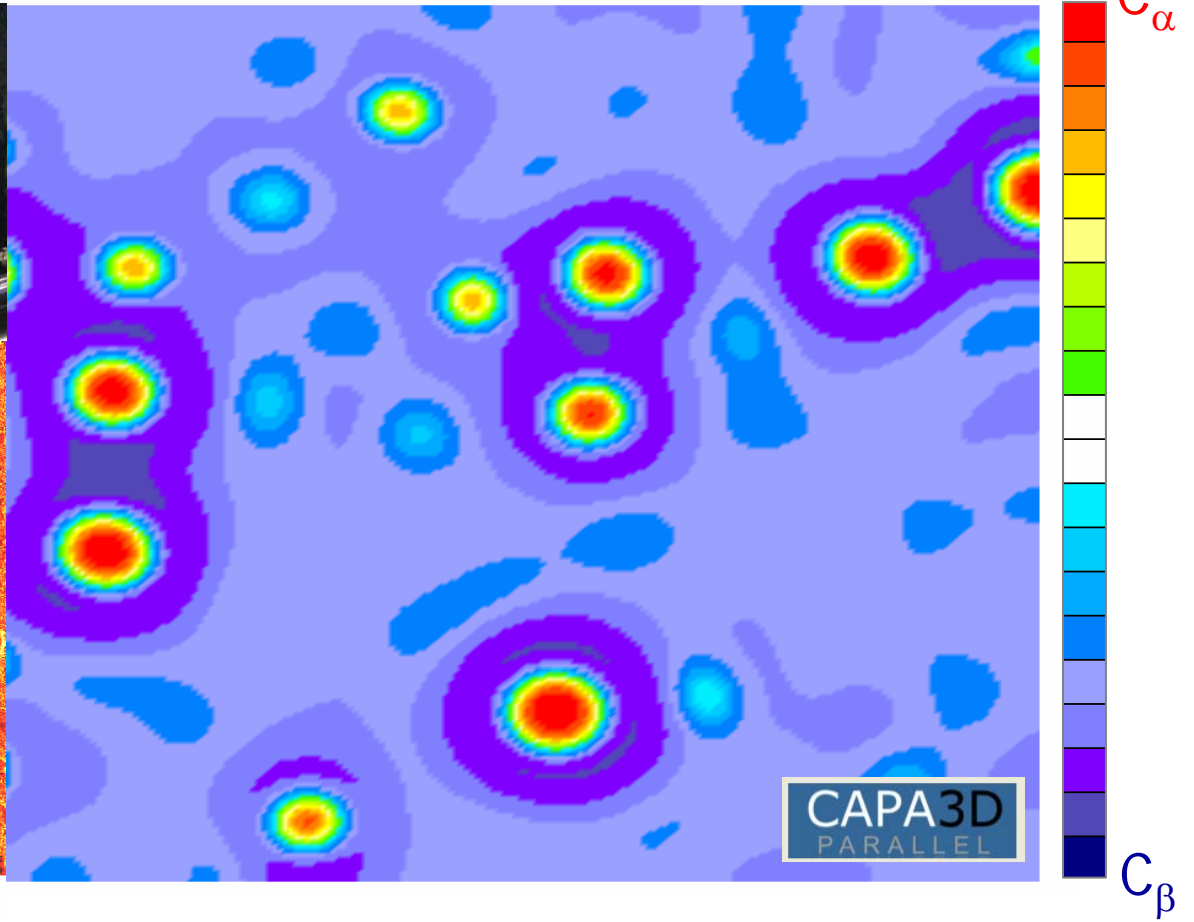
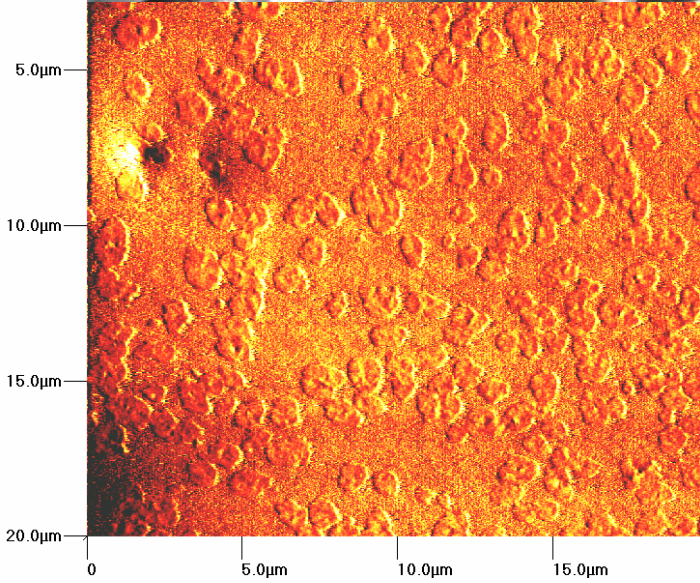
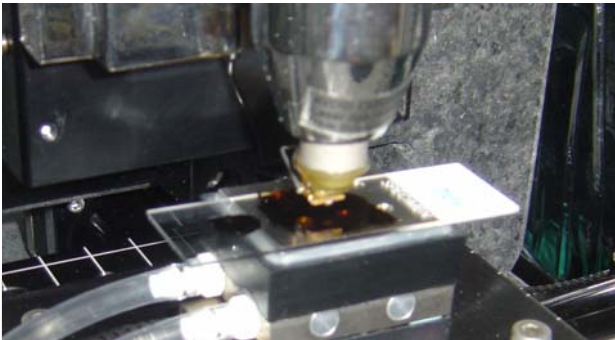
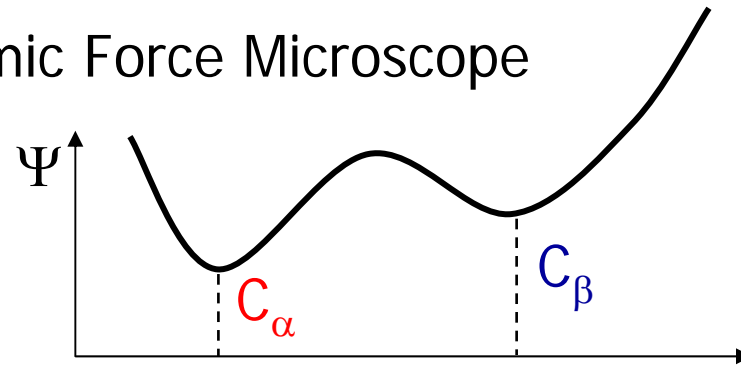
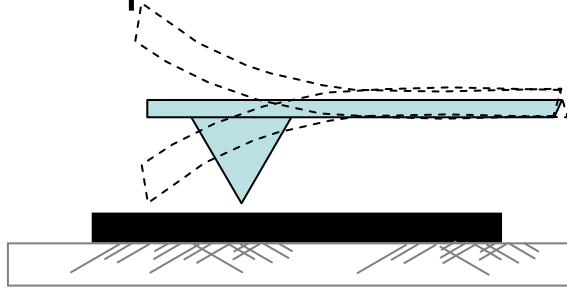

...asphalt under the Atomic Force Microscope

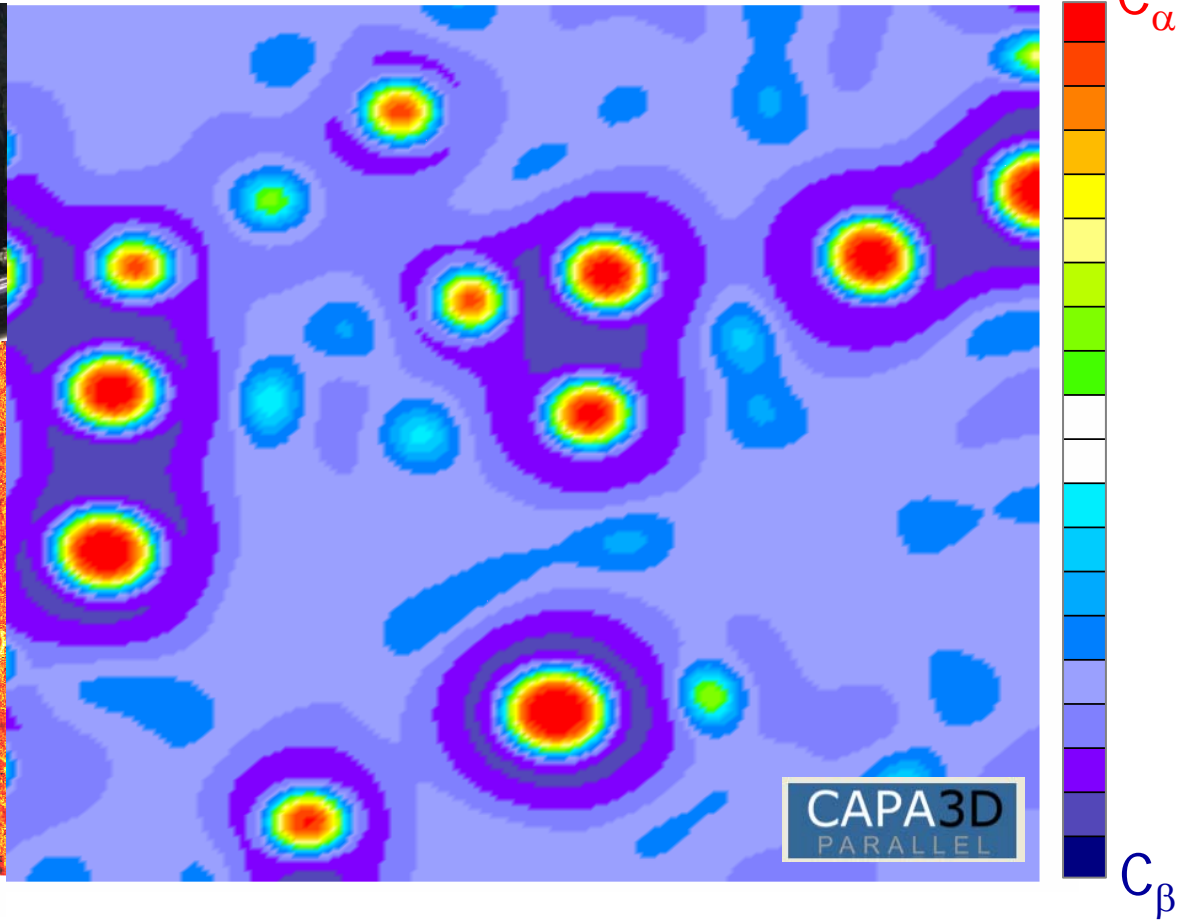
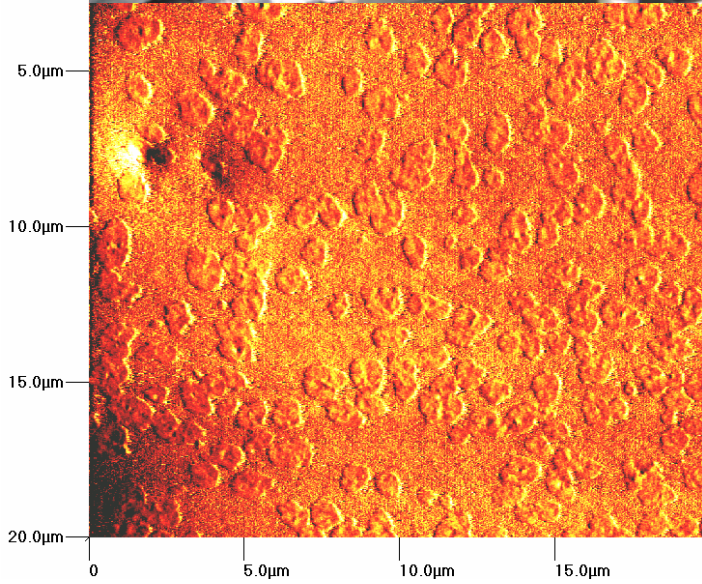
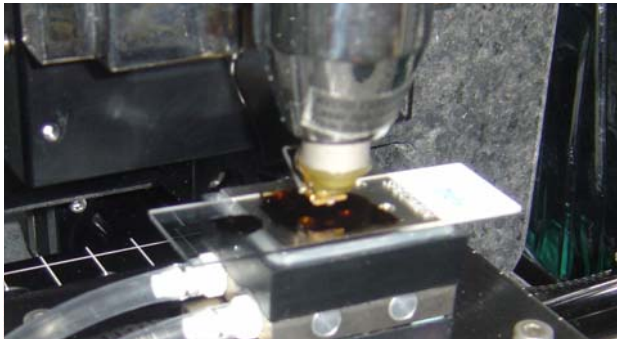
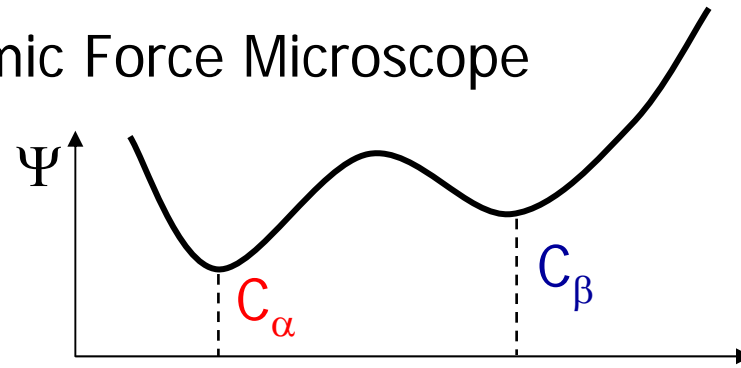
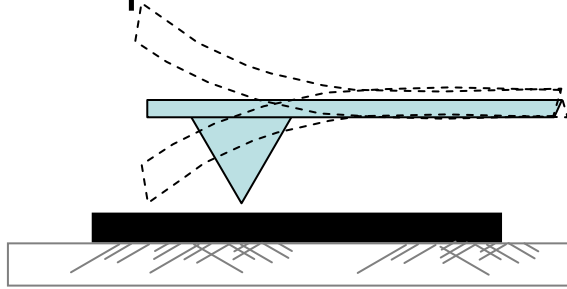

...asphalt under the Atomic Force Microscope

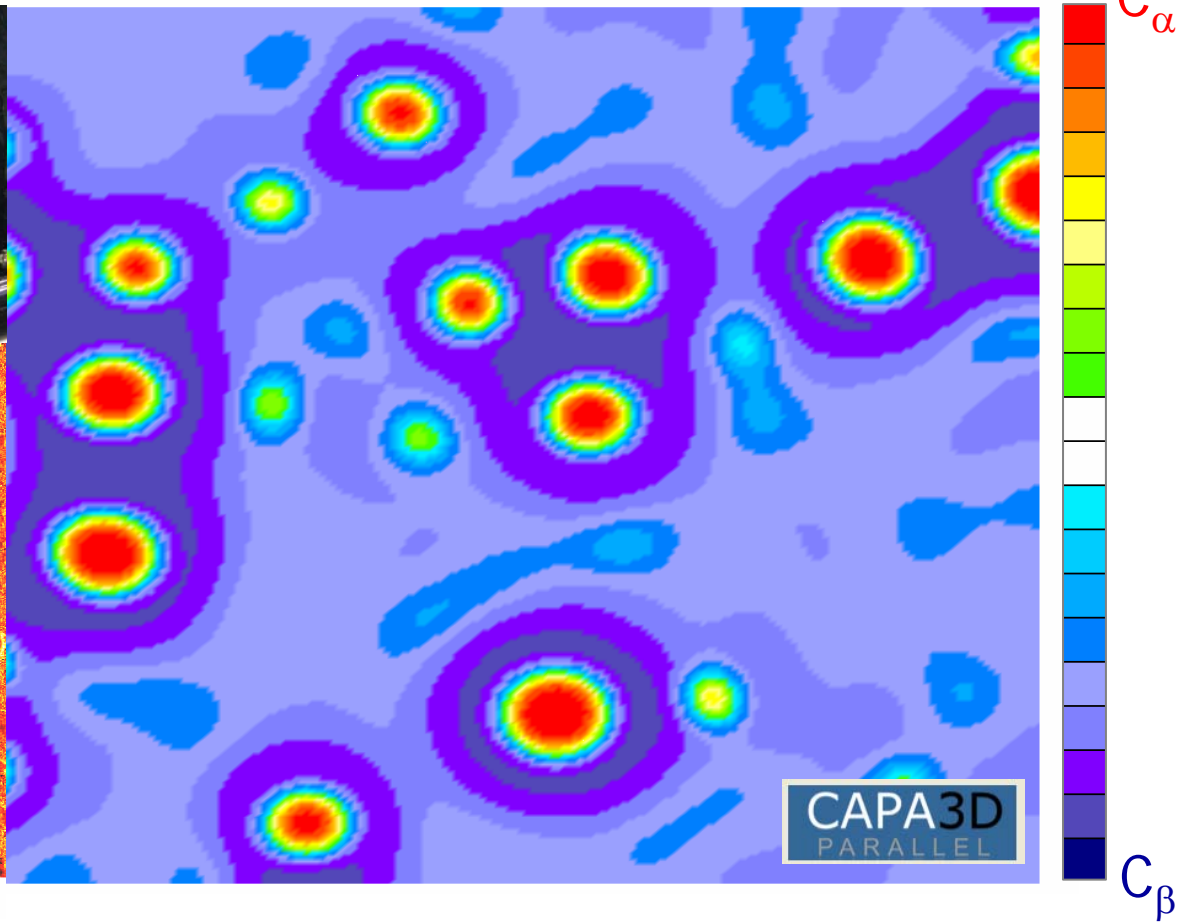
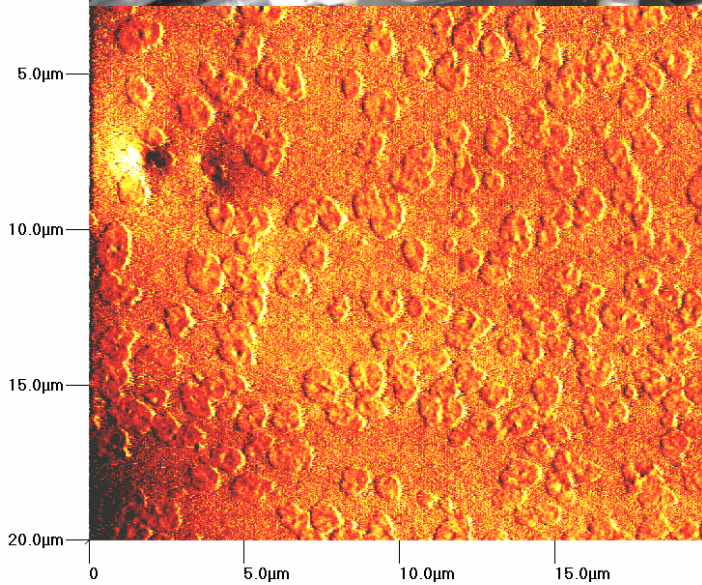
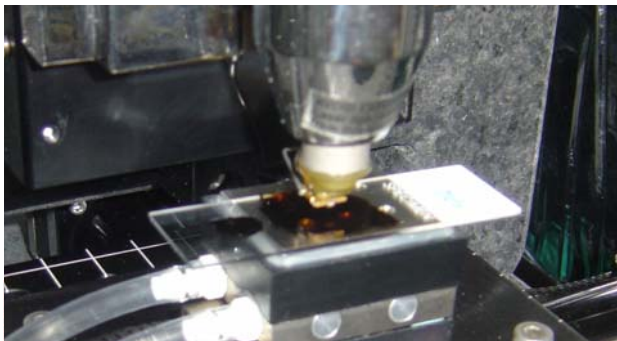
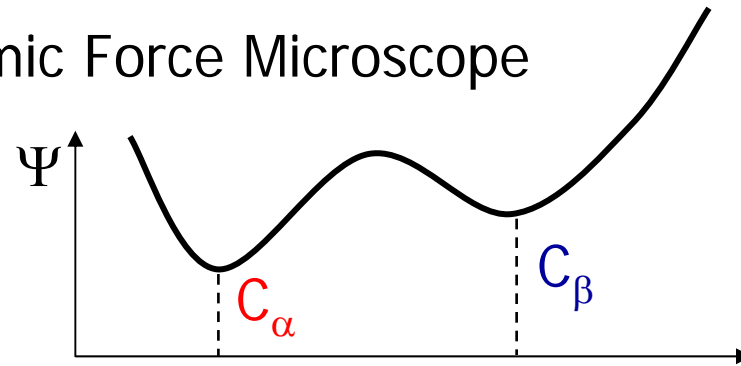
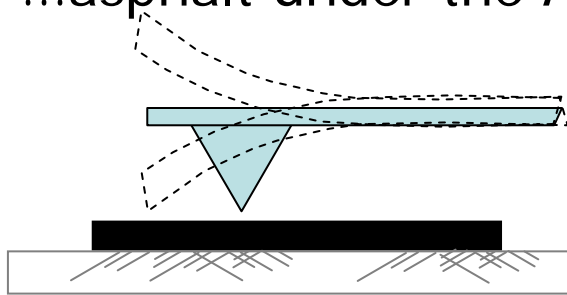

...asphalt under the Atomic Force Microscope

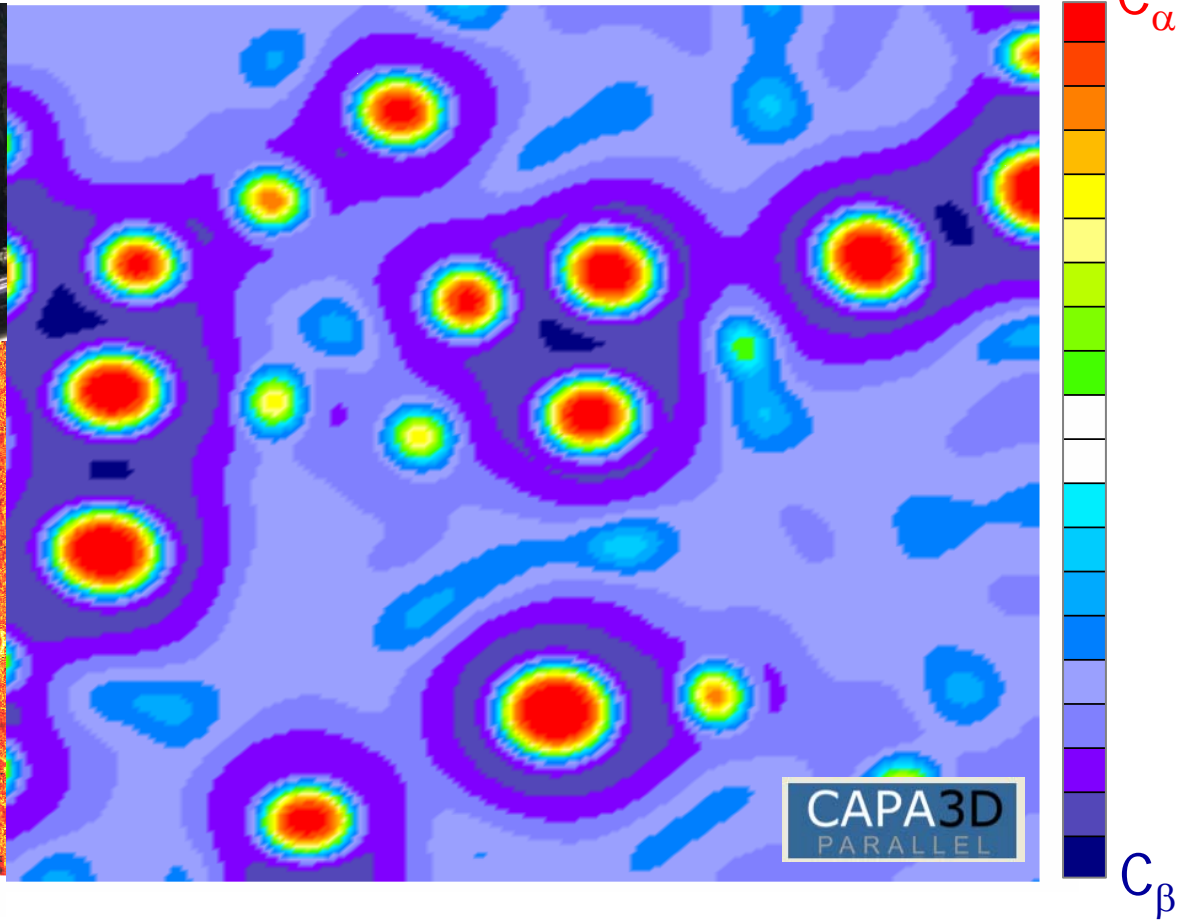
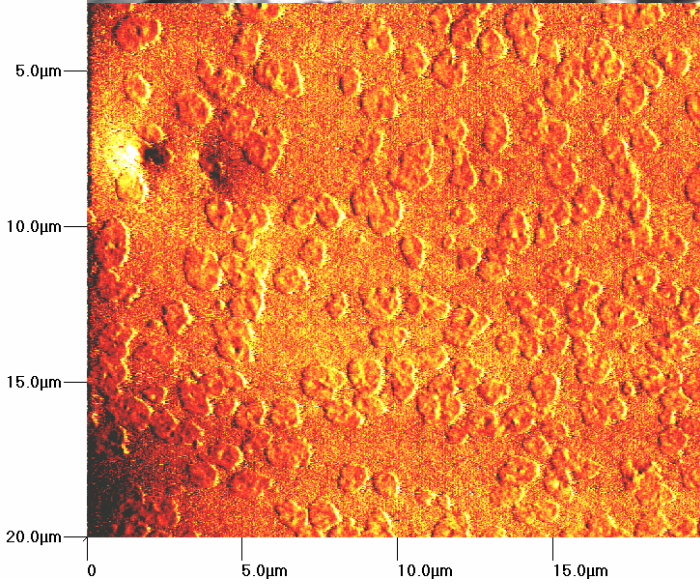
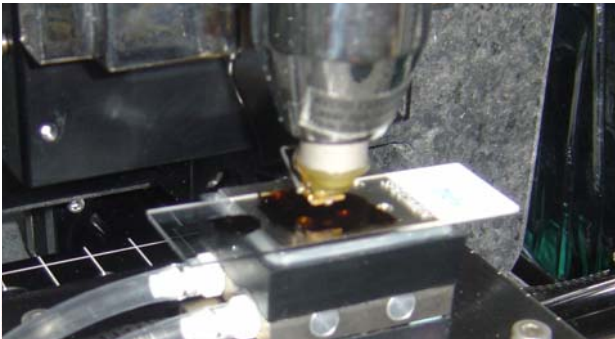
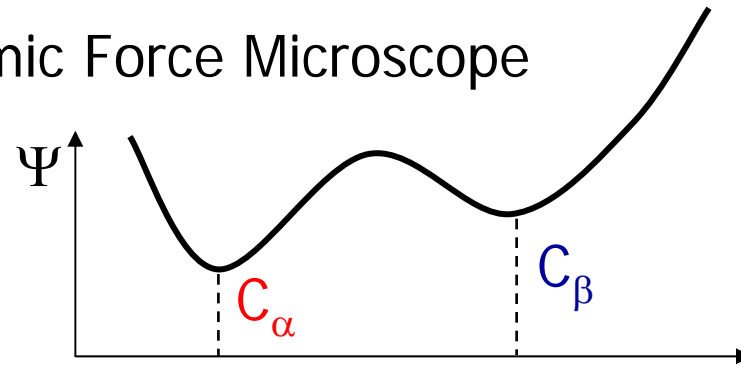
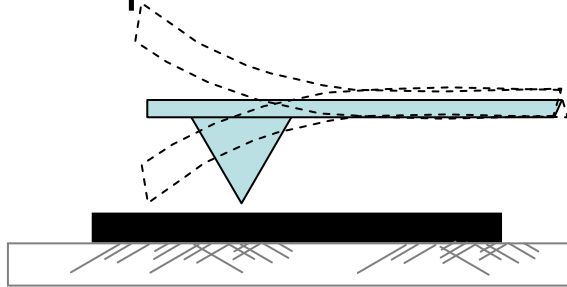

...asphalt under the Atomic Force Microscope

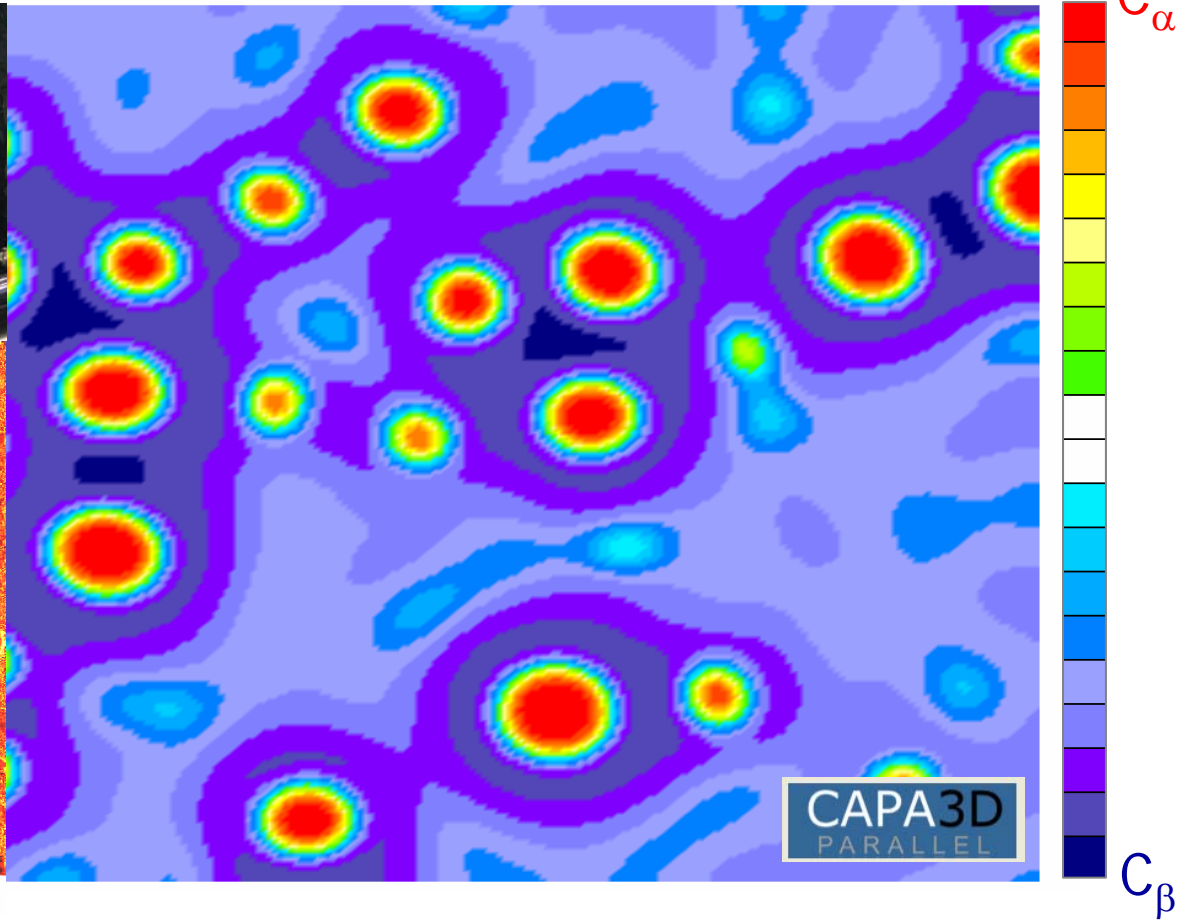
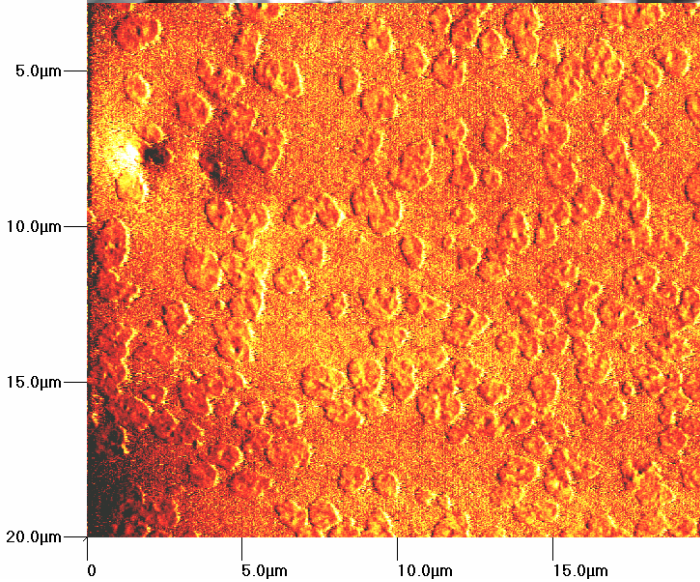
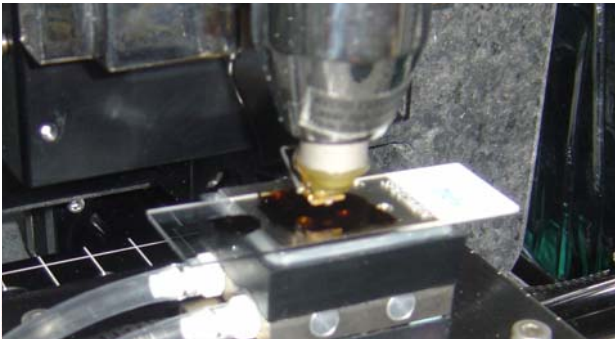
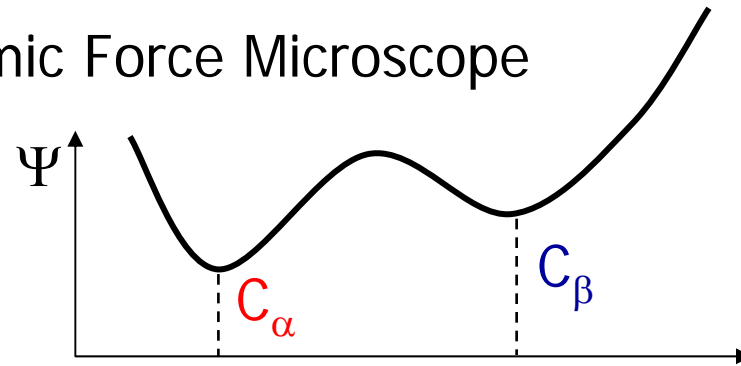
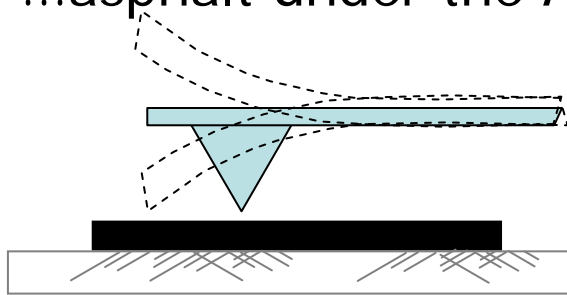

...asphalt under the Atomic Force Microscope

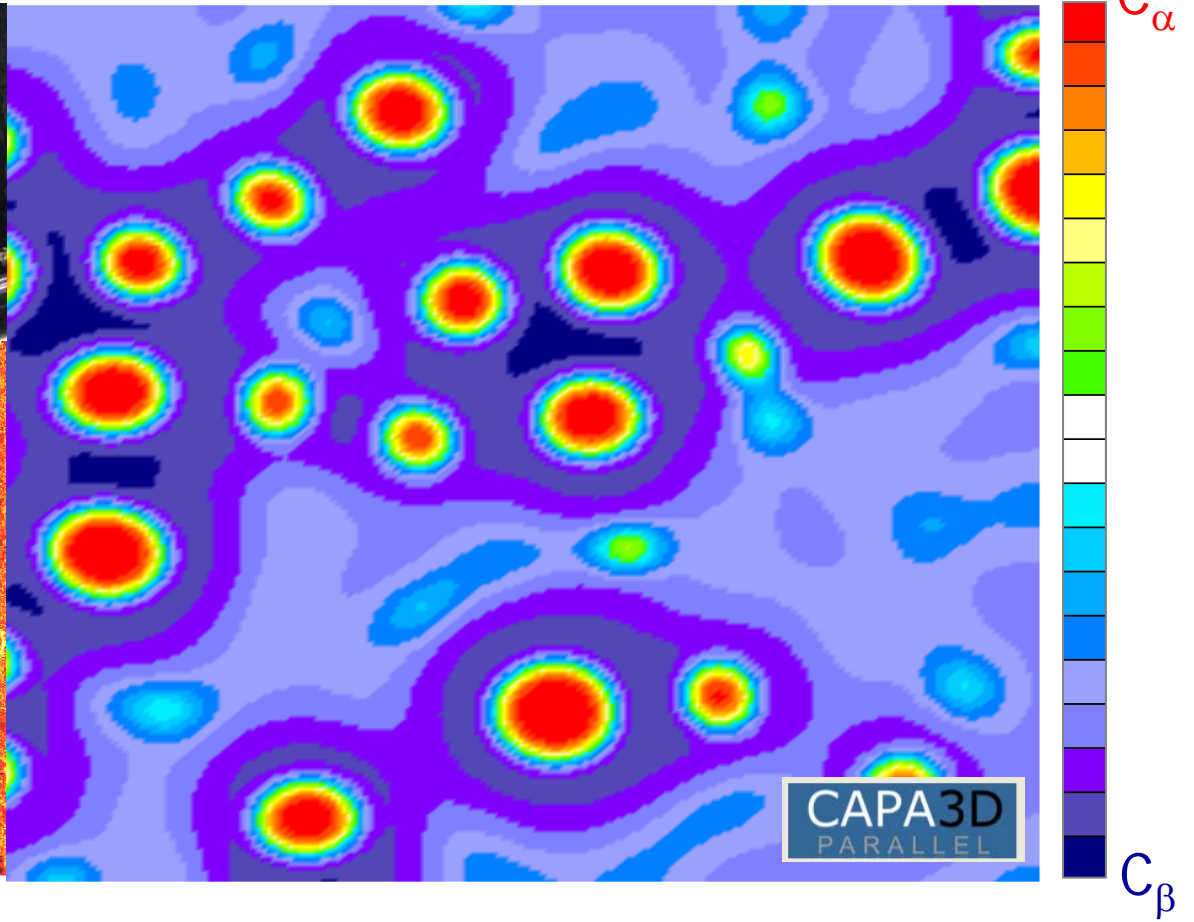
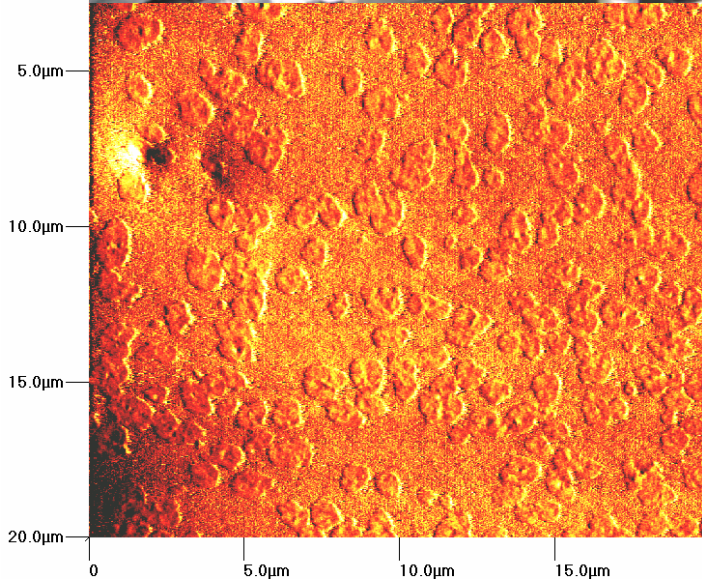
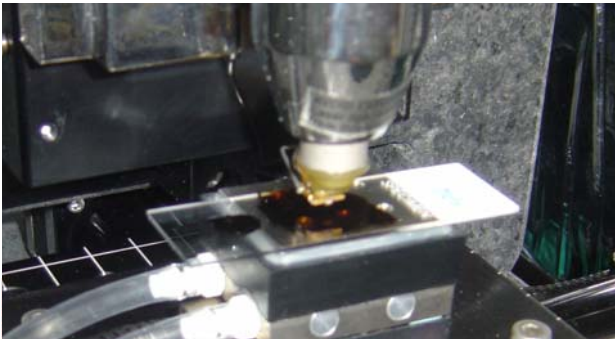
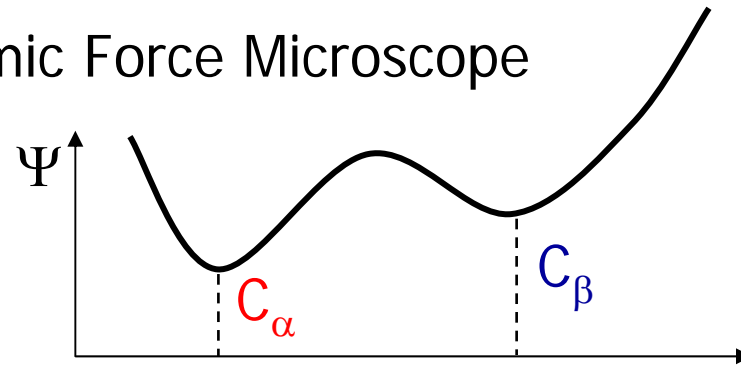
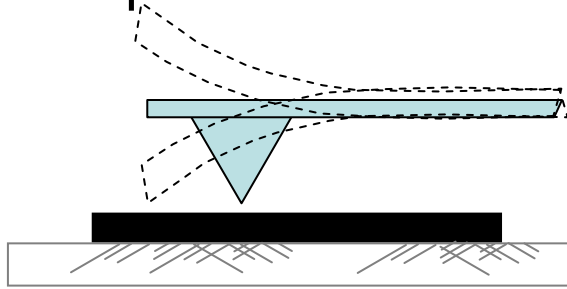

...asphalt under the Atomic Force Microscope

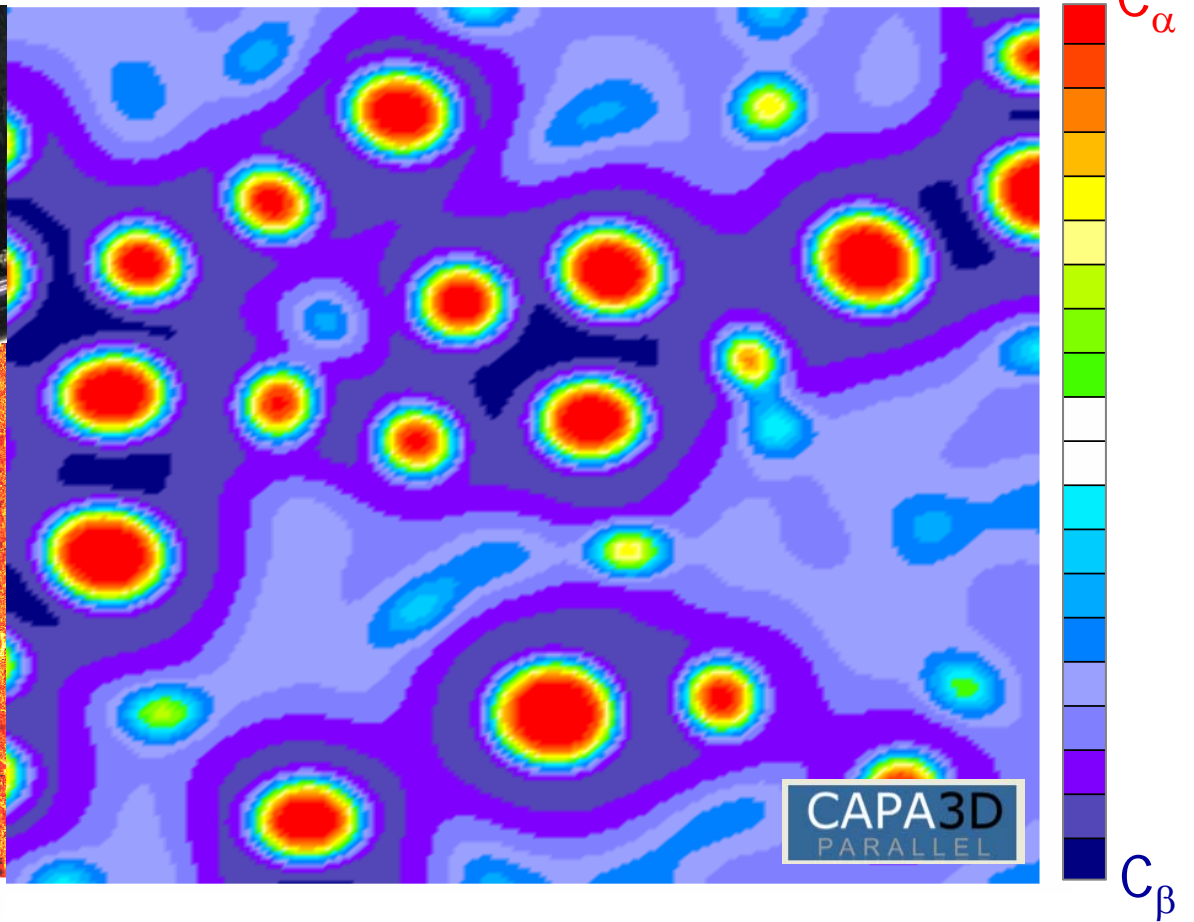
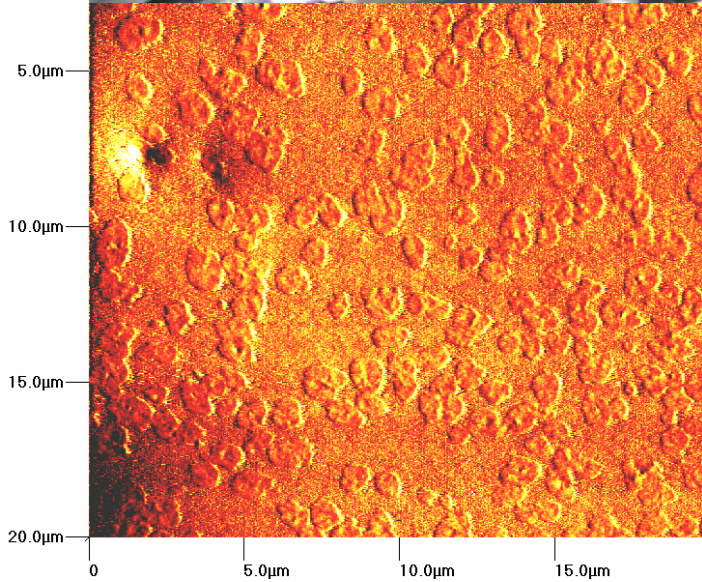
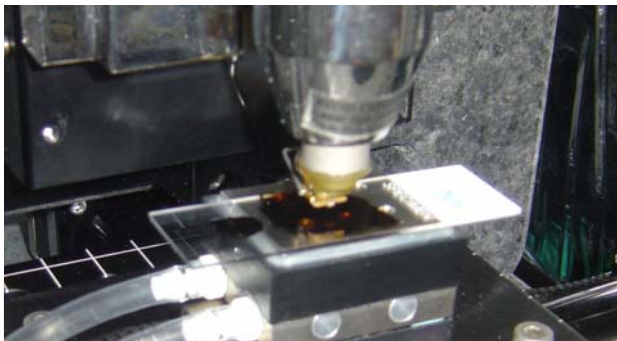
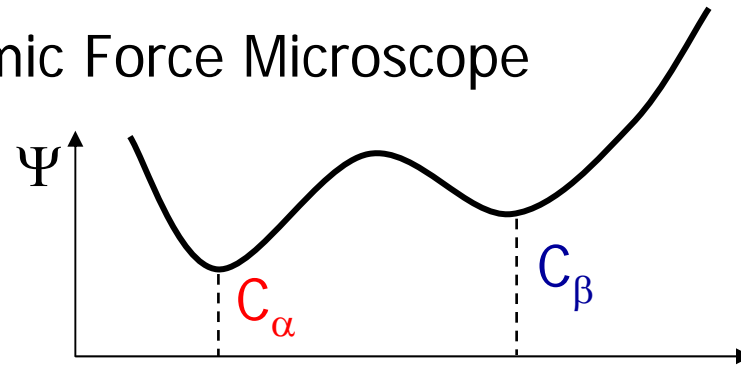
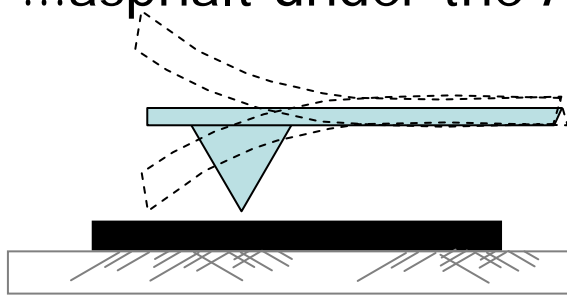

...asphalt under the Atomic Force Microscope

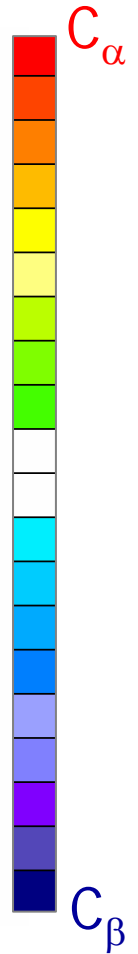
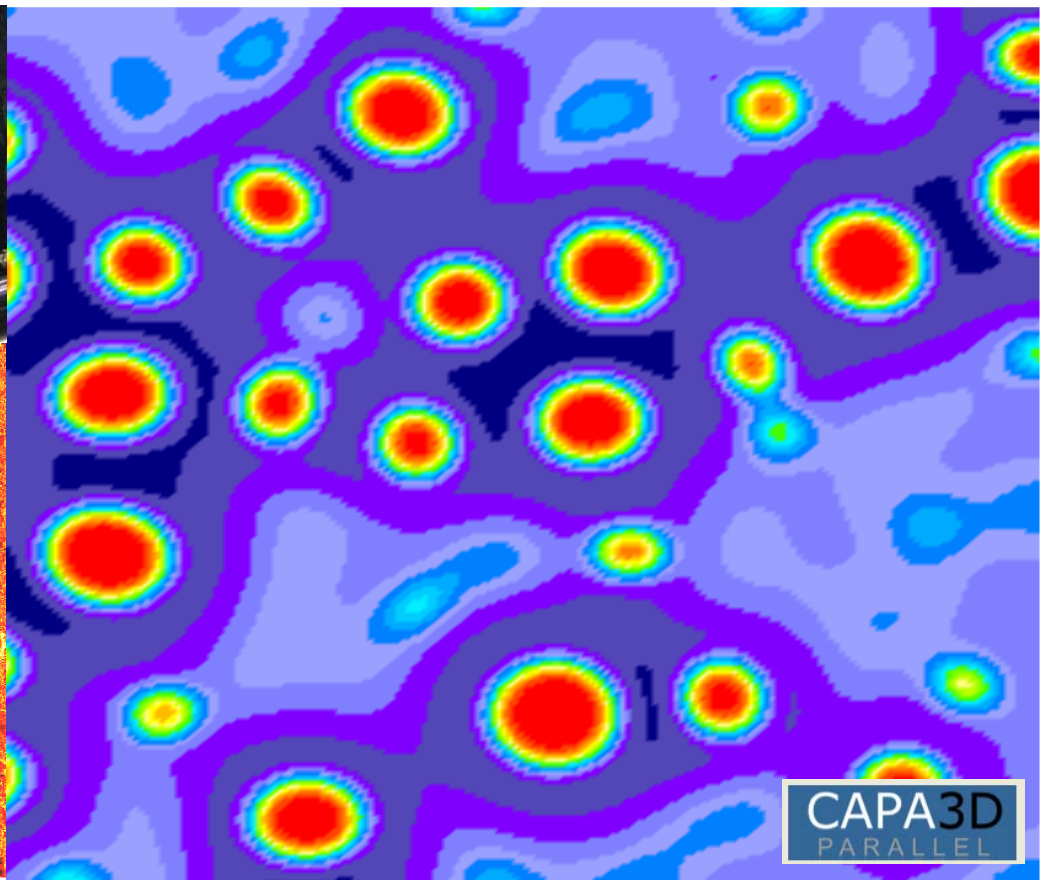
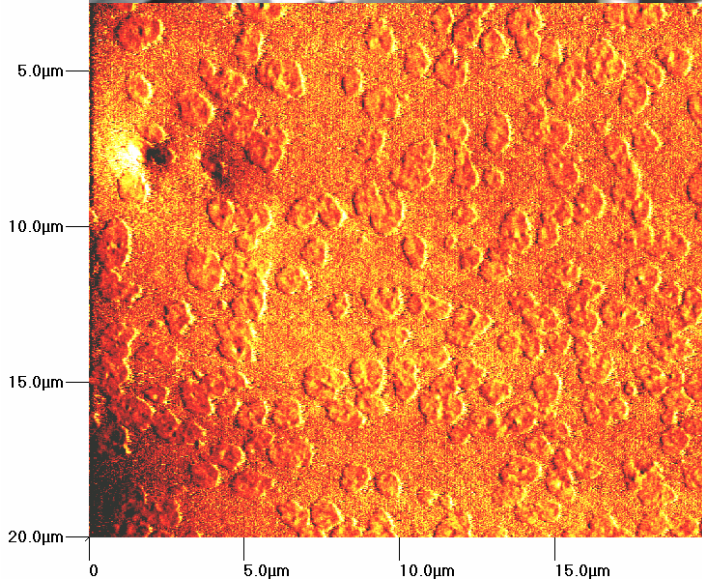
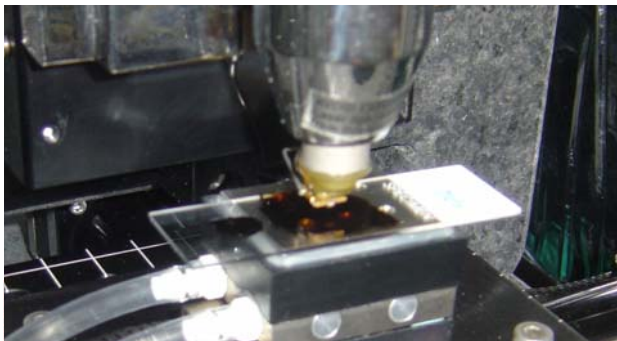
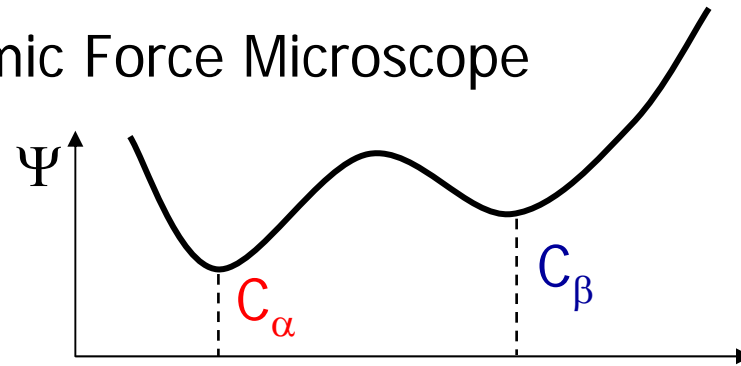
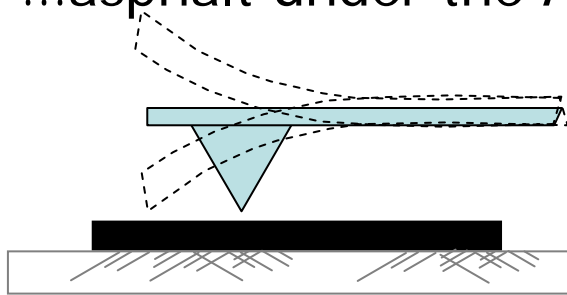

...asphalt under the Atomic Force Microscope

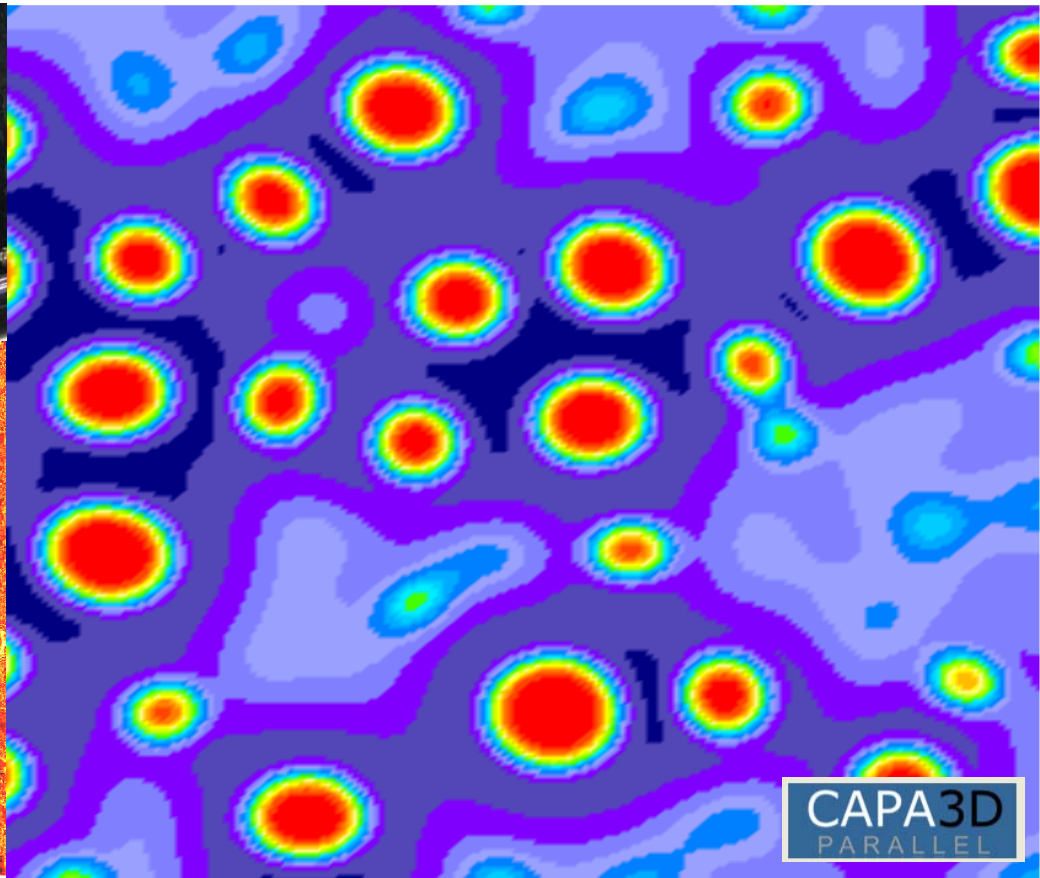
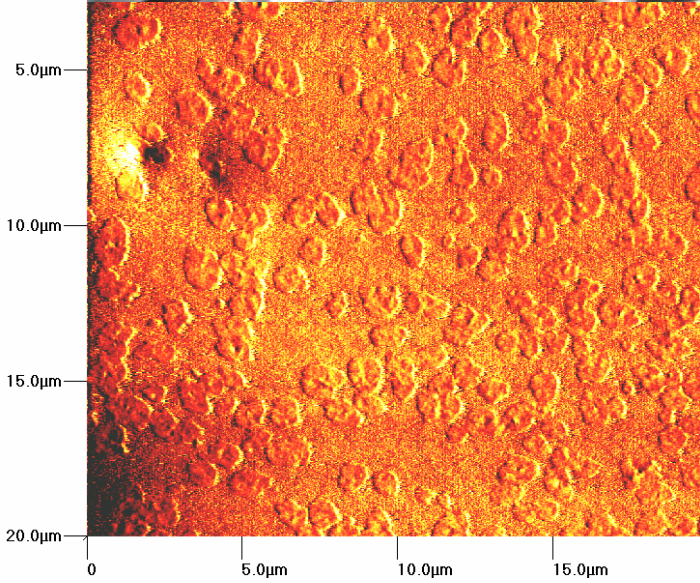
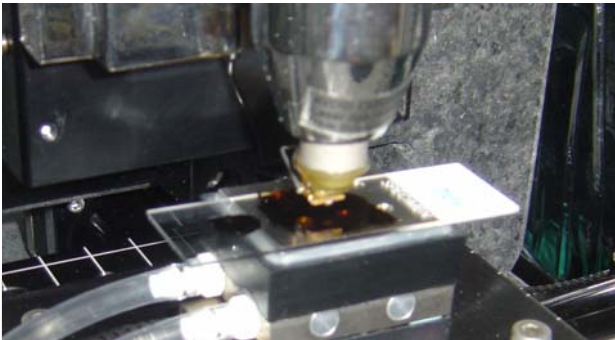
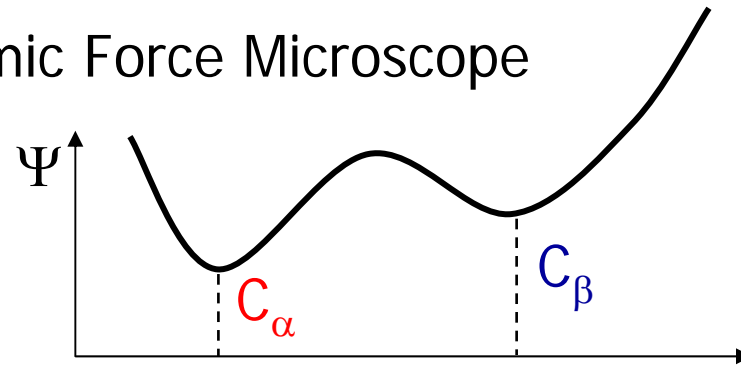
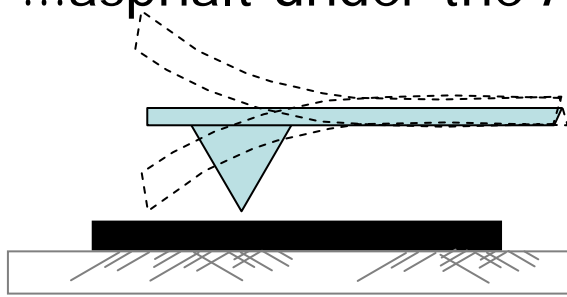

CAPA3D
PARALLEL

...asphalt under the Atomic Force Microscope

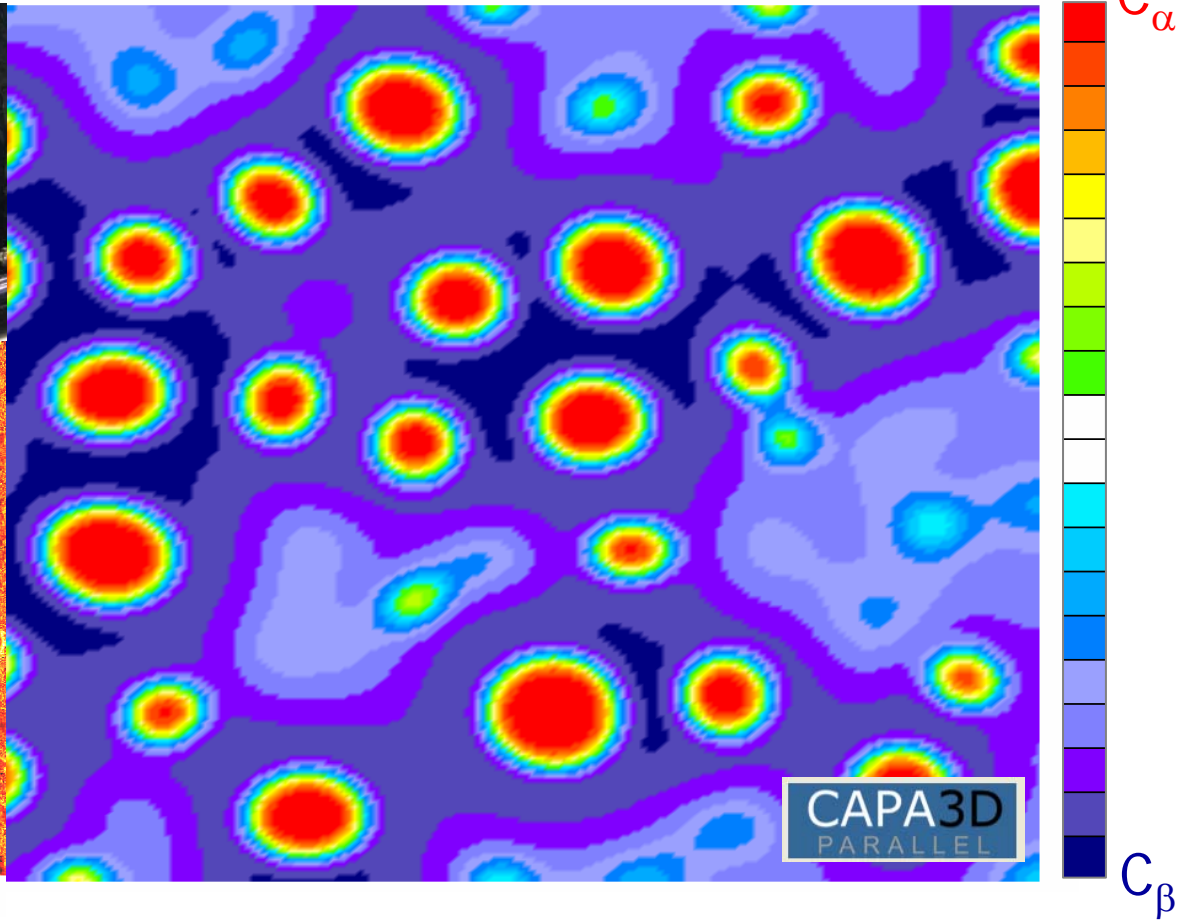
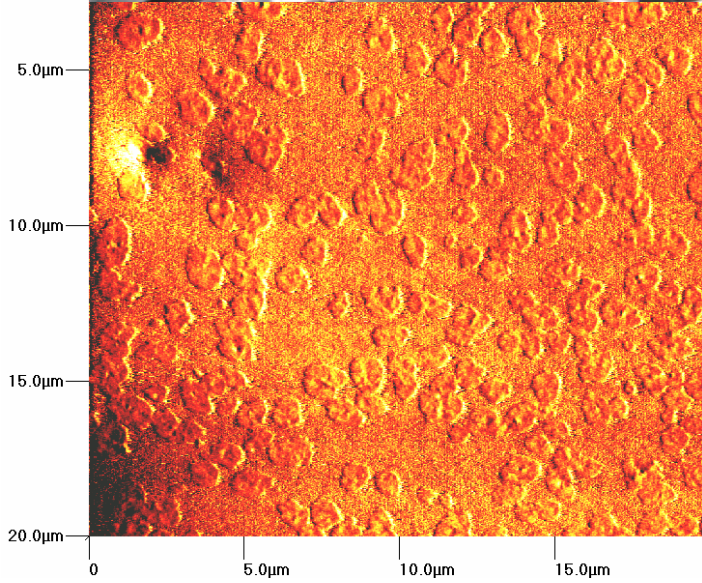
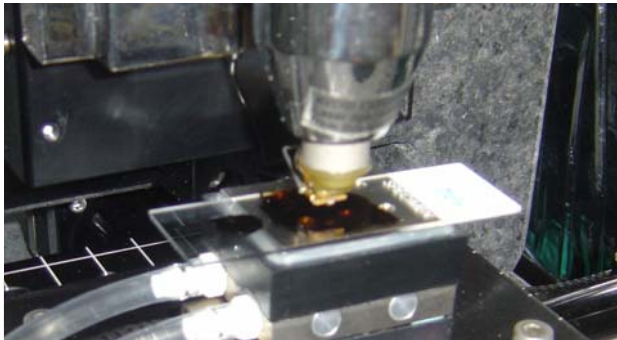
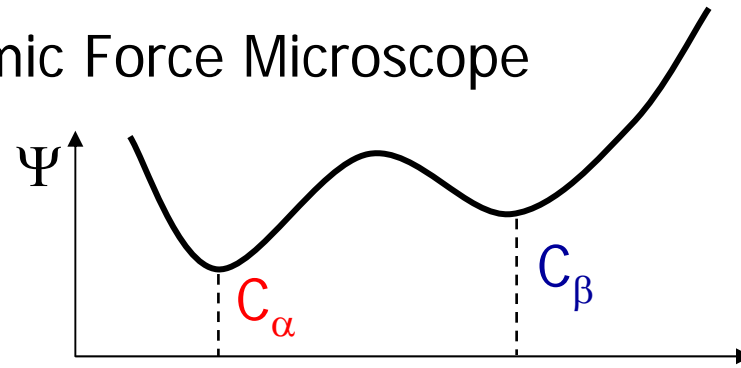
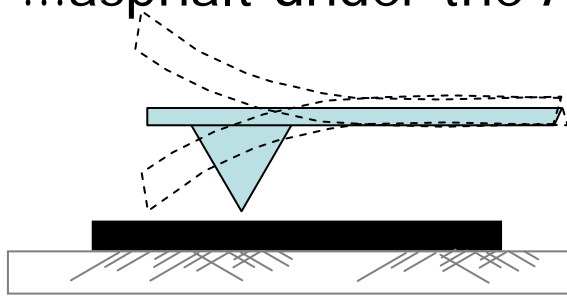

...asphalt under the Atomic Force Microscope

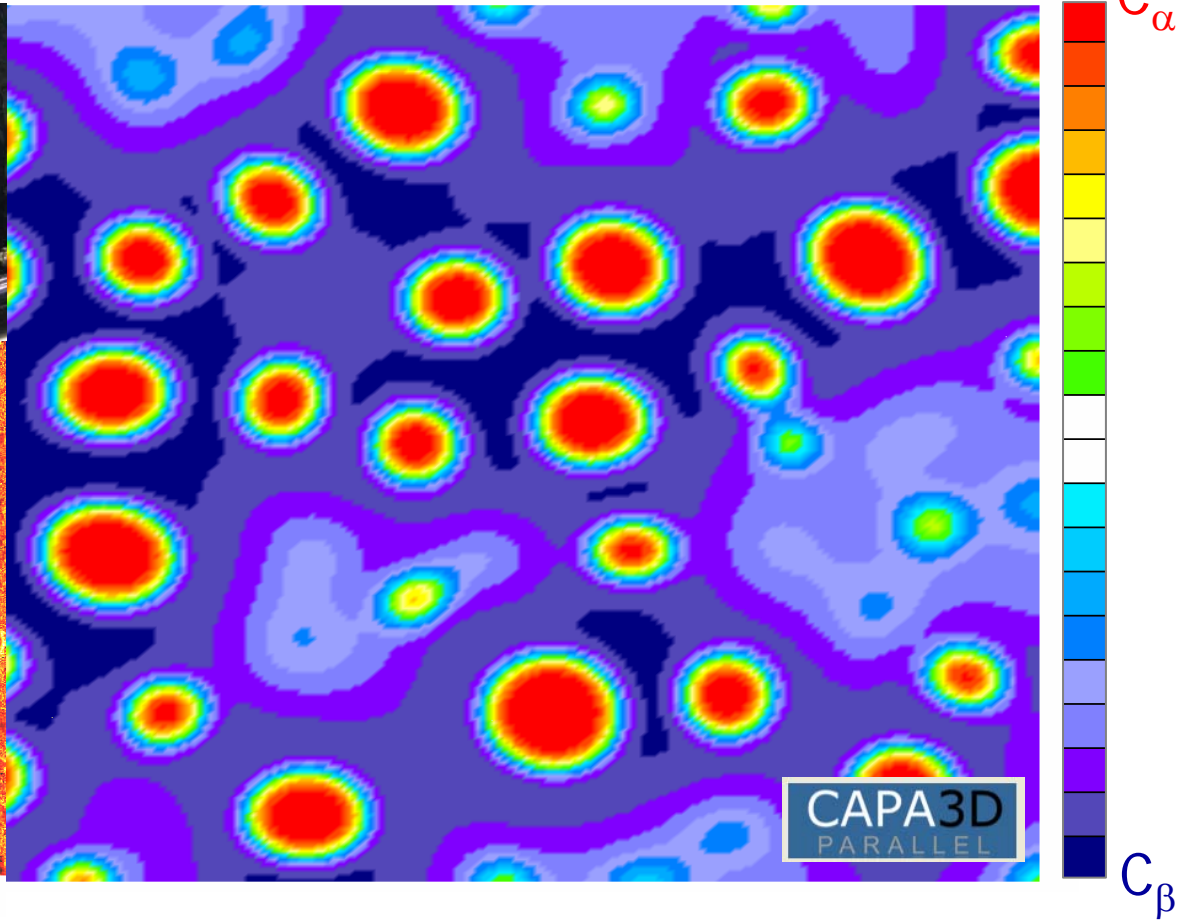
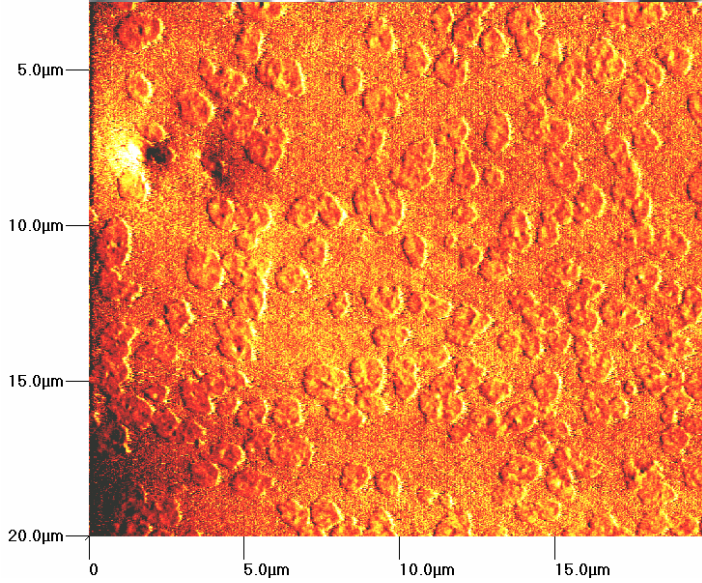
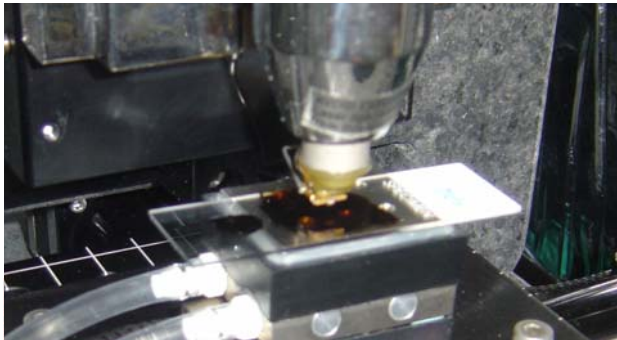
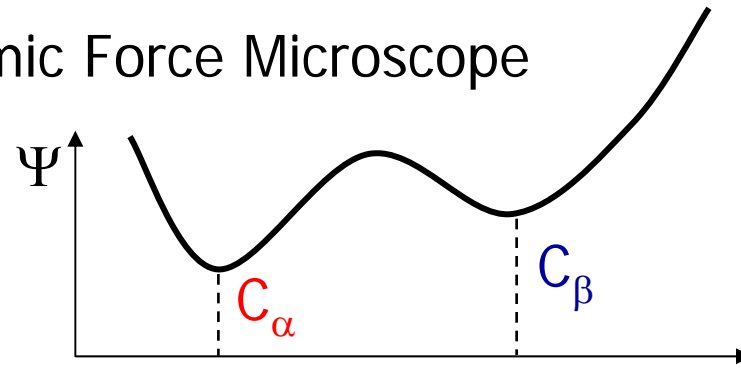
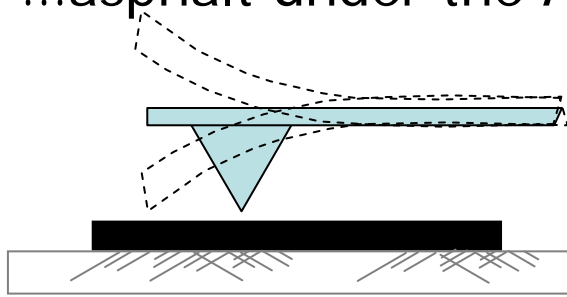

...asphalt under the Atomic Force Microscope

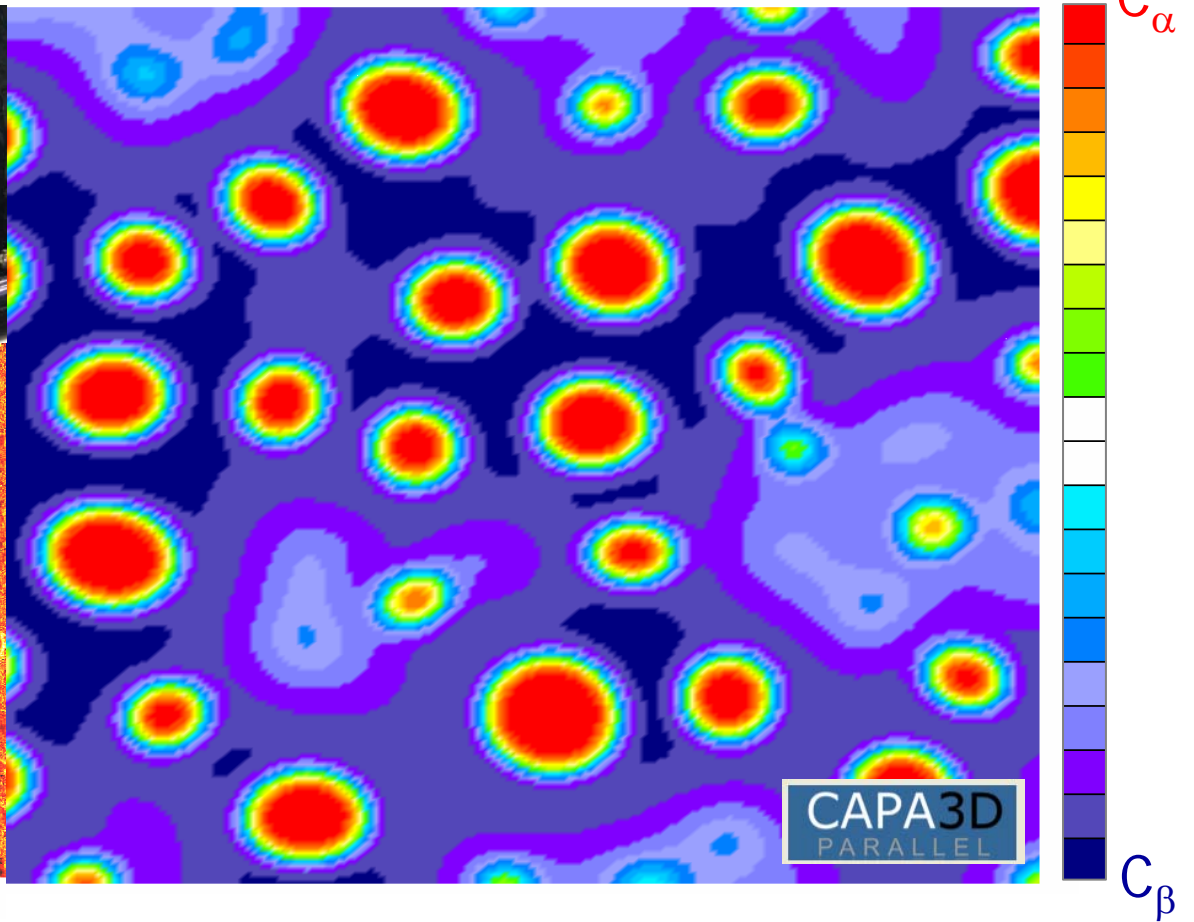
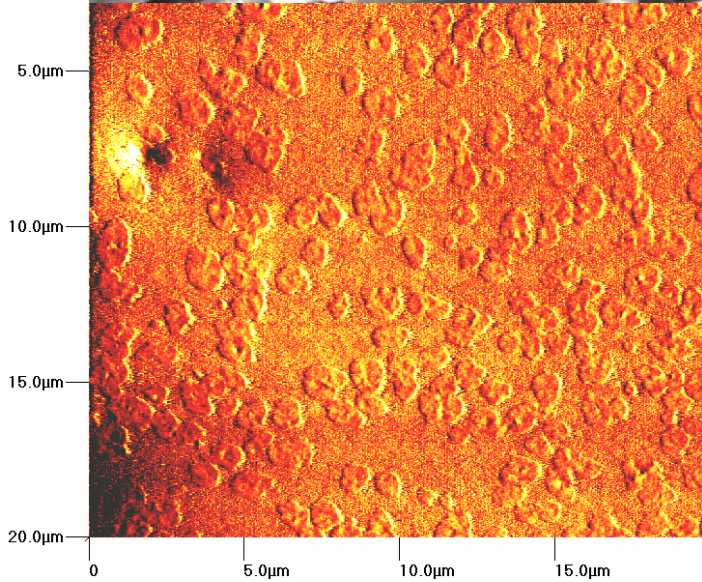
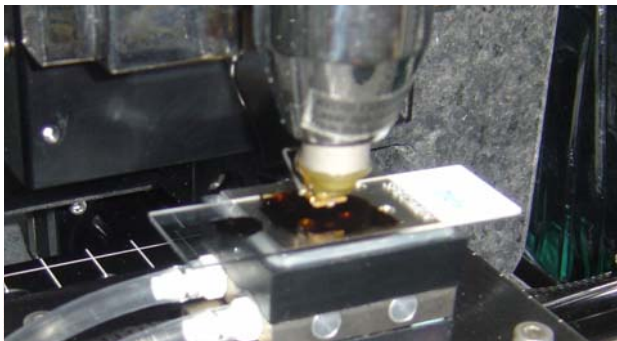
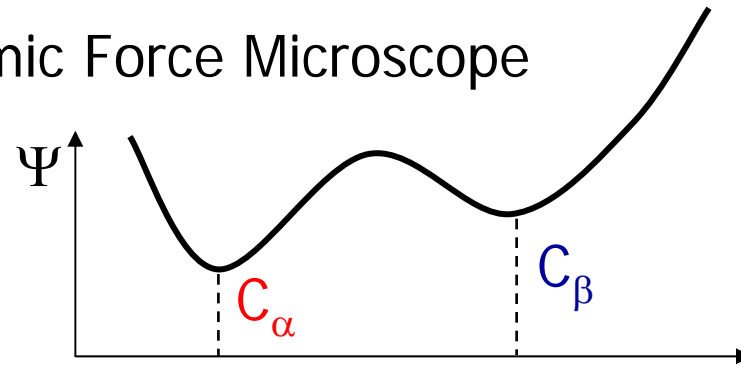
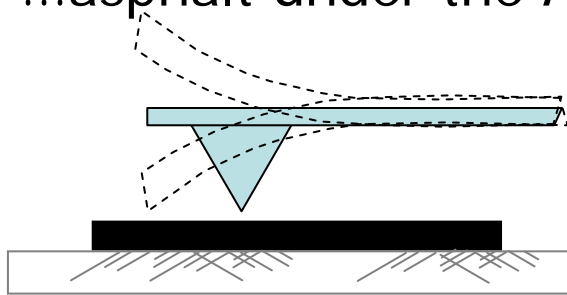

...asphalt under the Atomic Force Microscope

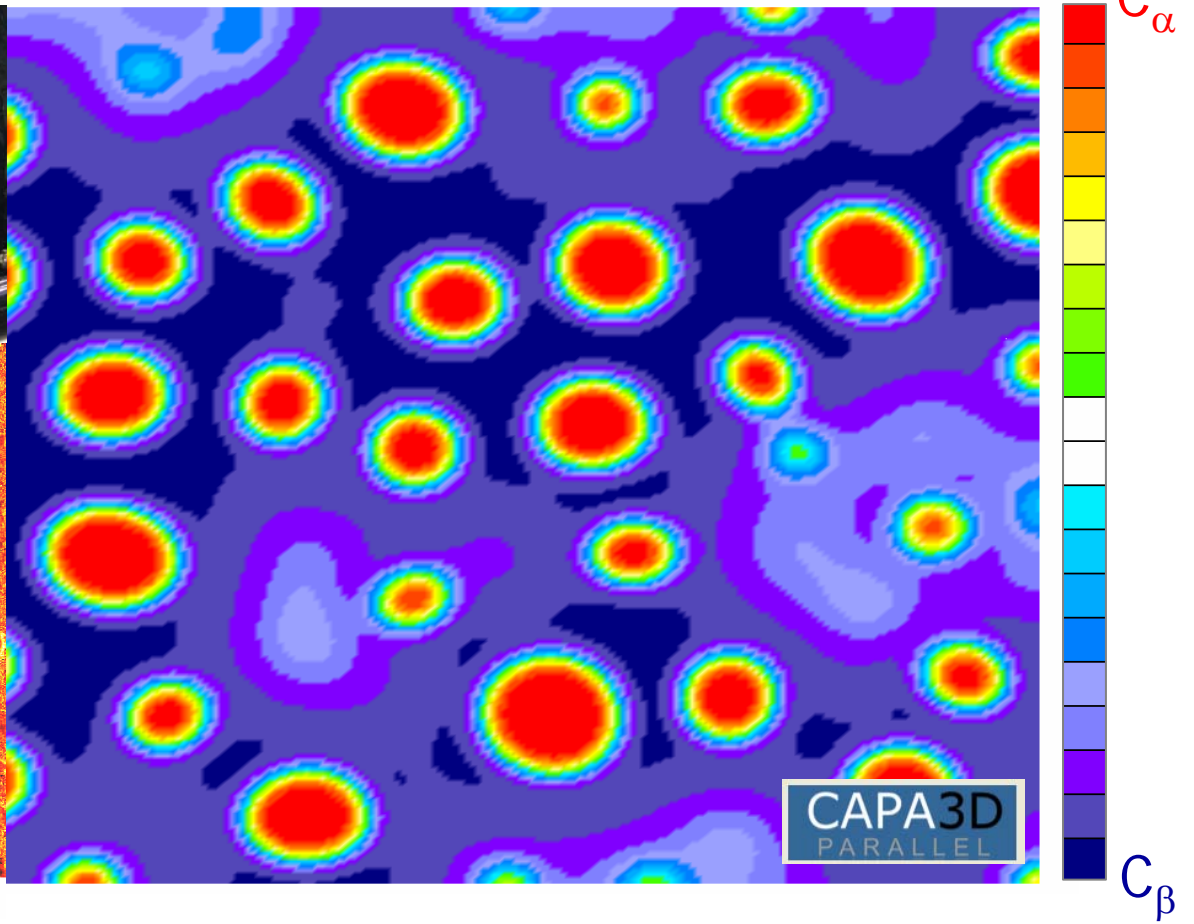
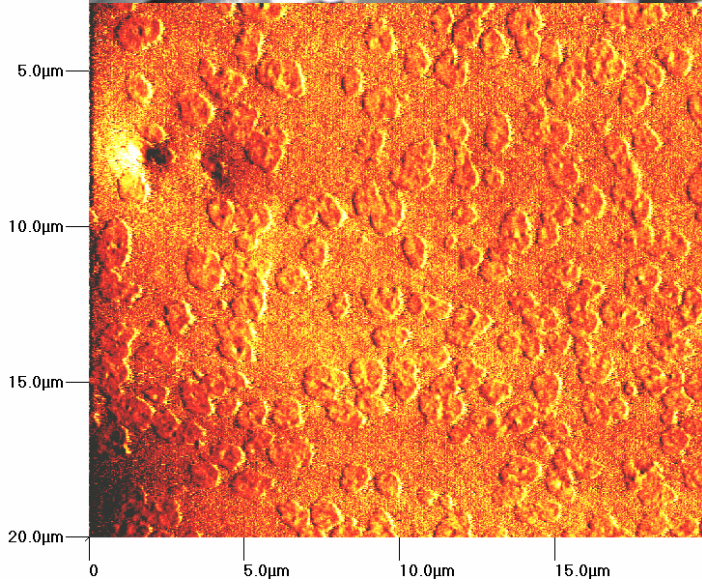
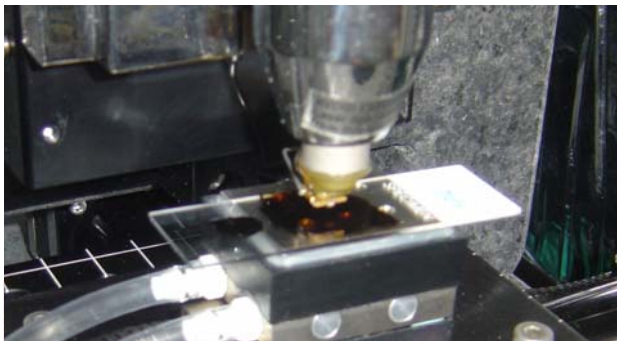
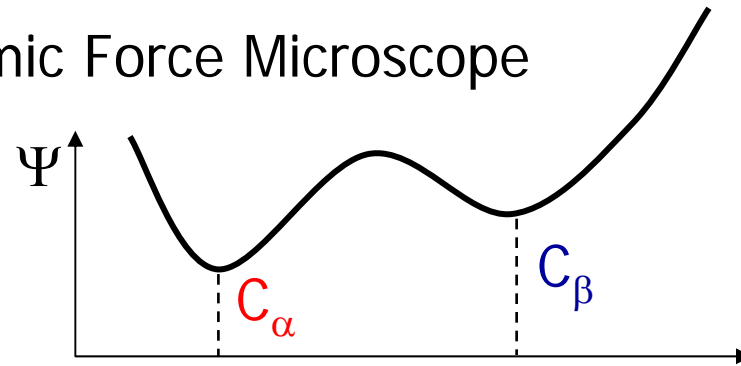
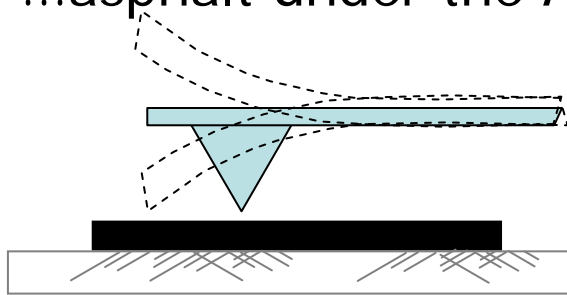

...asphalt under the Atomic Force Microscope

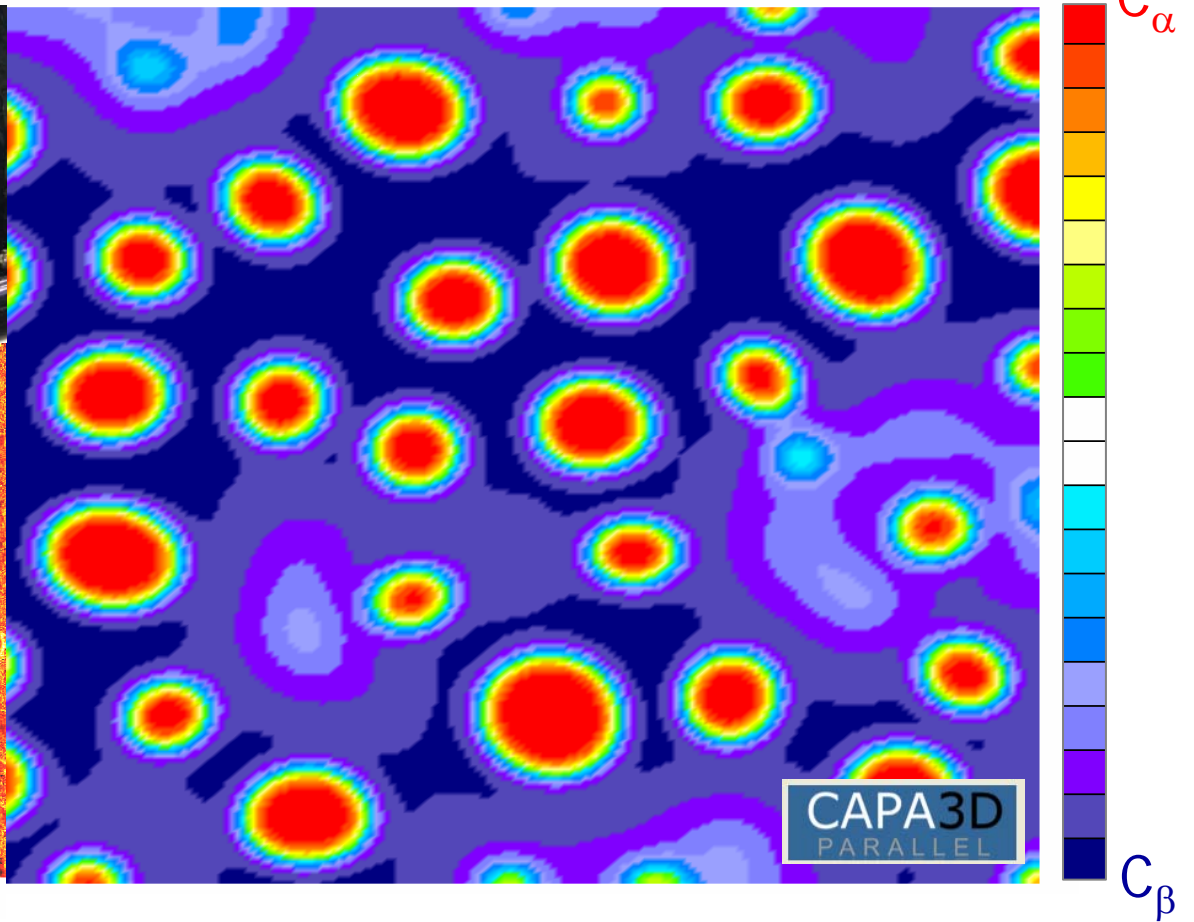
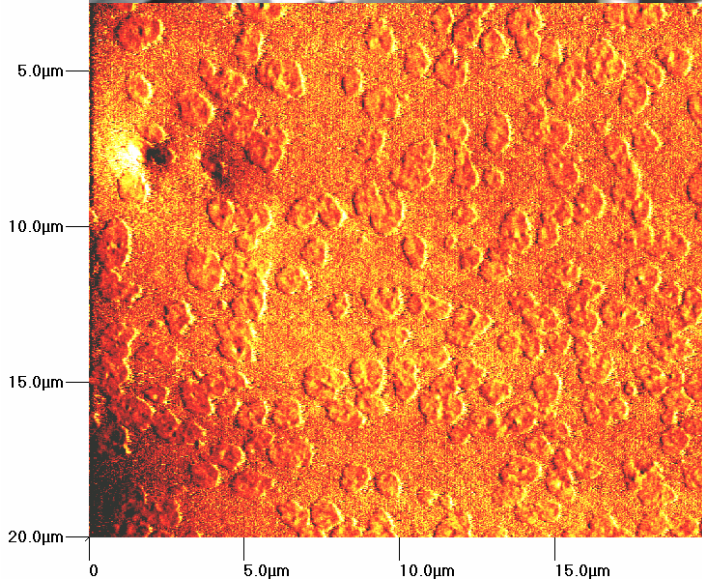
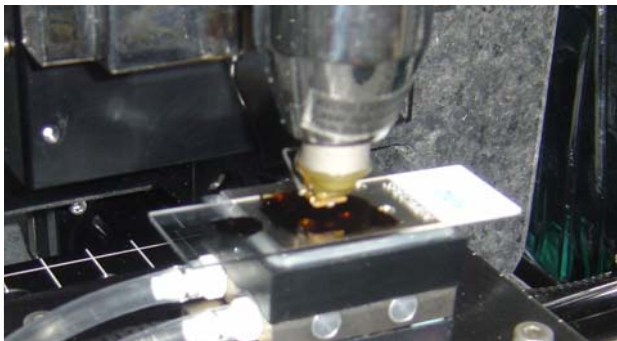
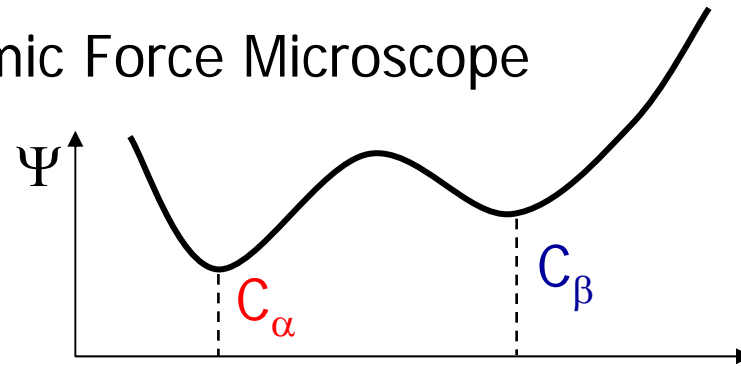
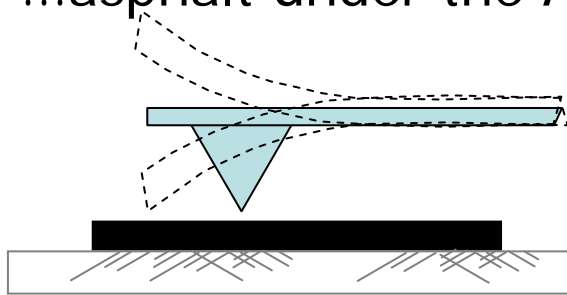

...asphalt under the Atomic Force Microscope

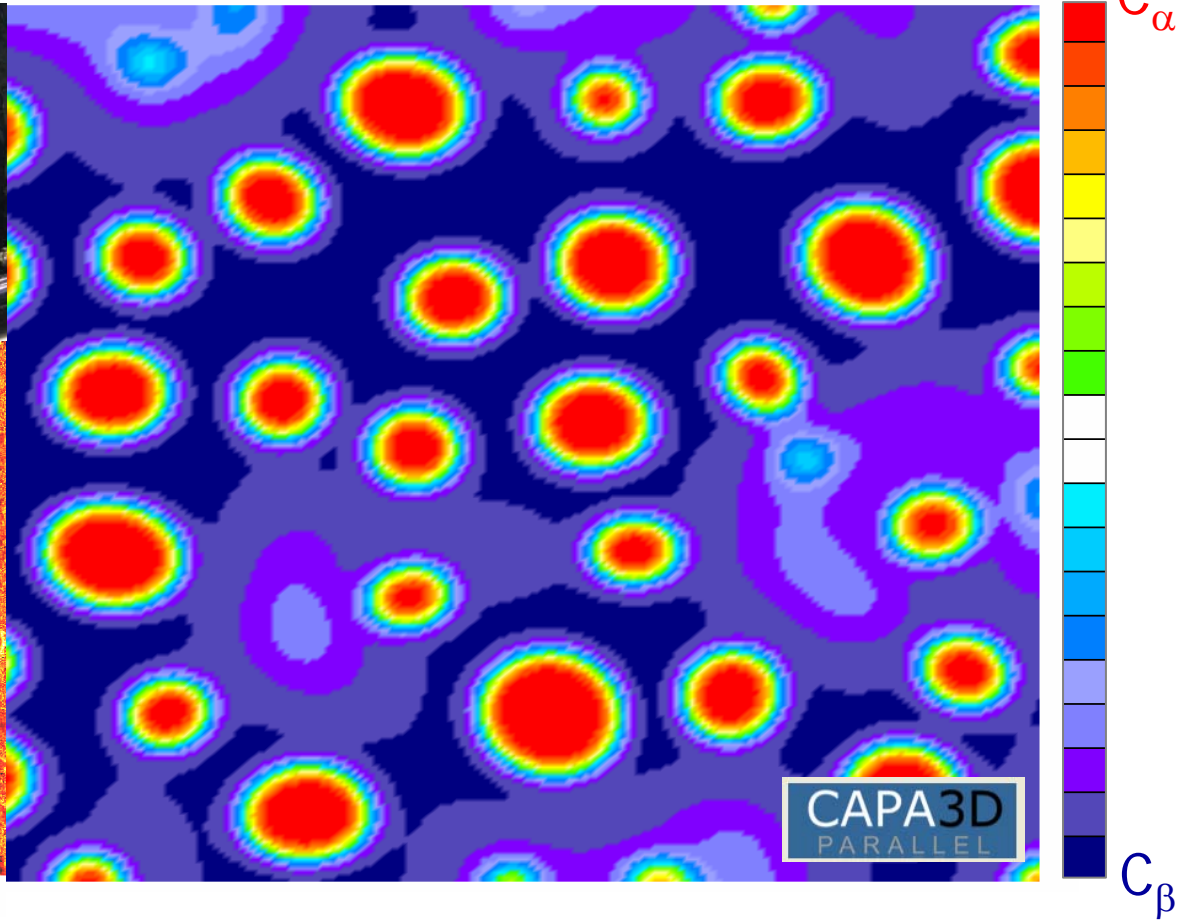
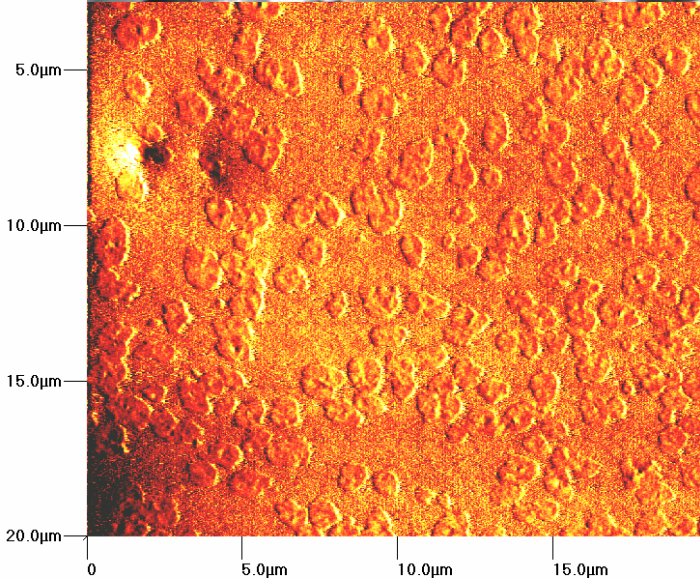
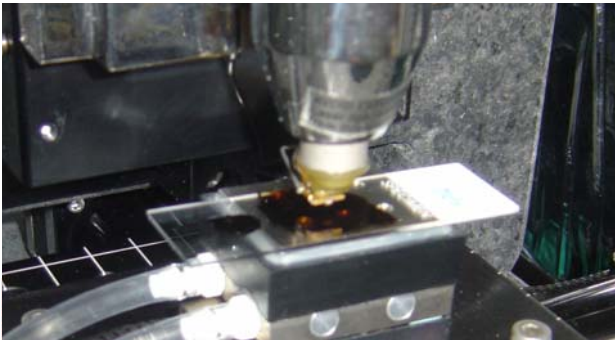
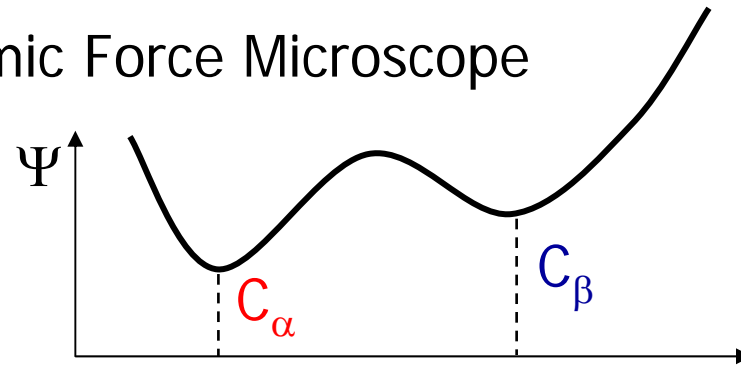
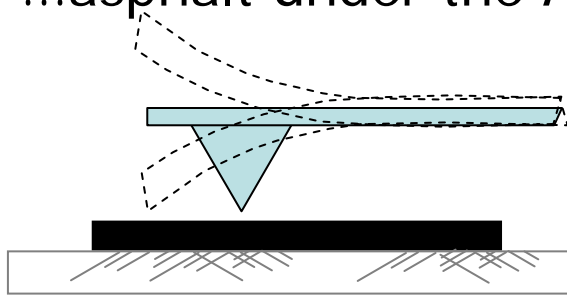

...asphalt under the Atomic Force Microscope

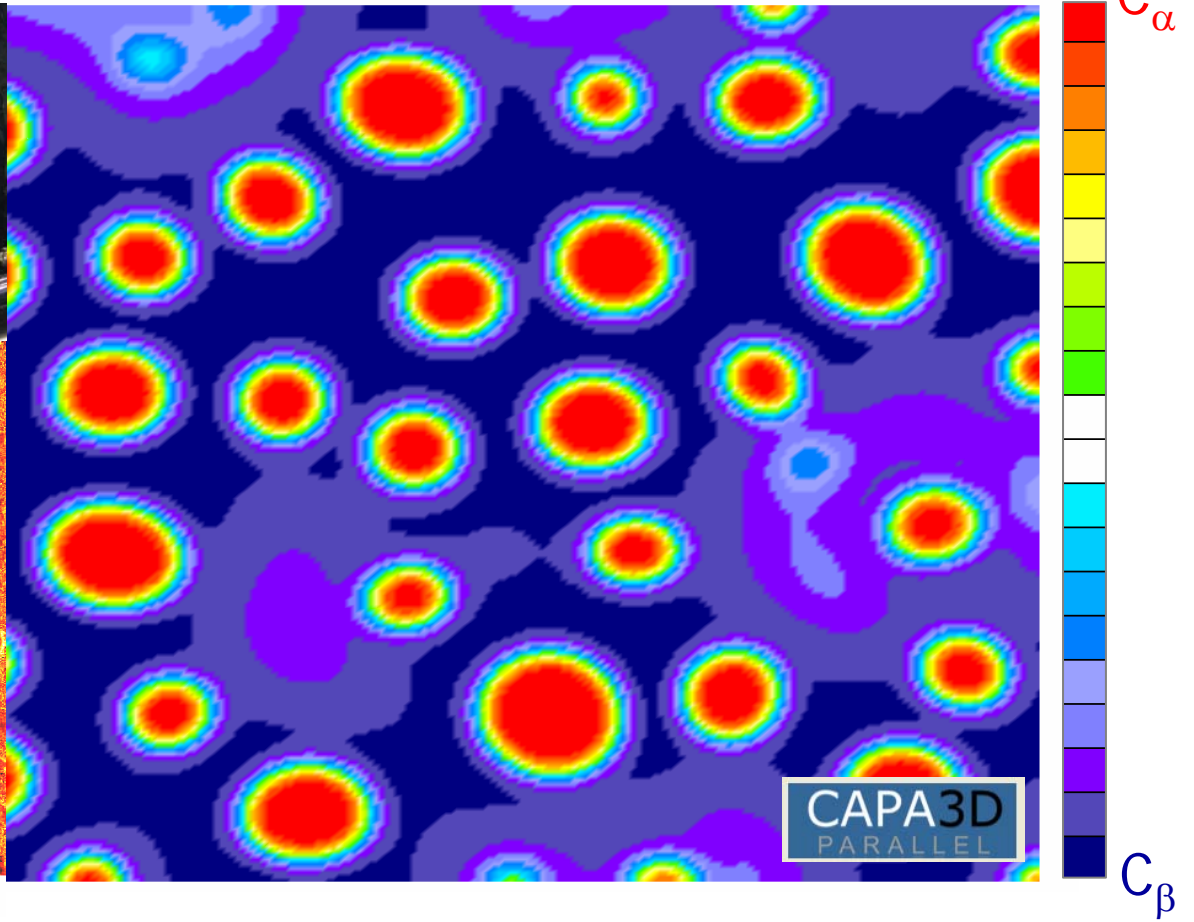
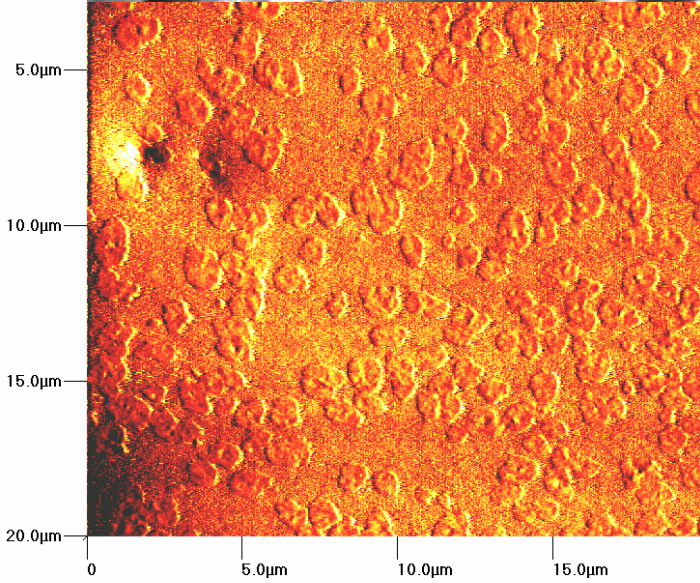
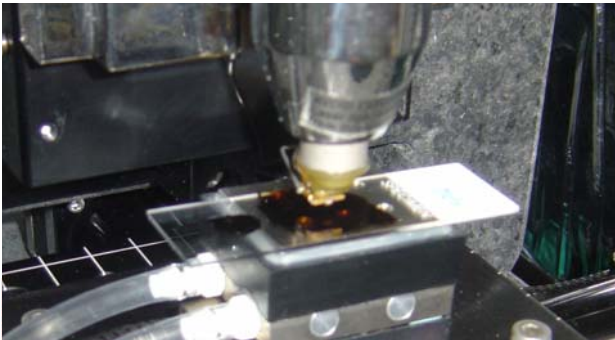
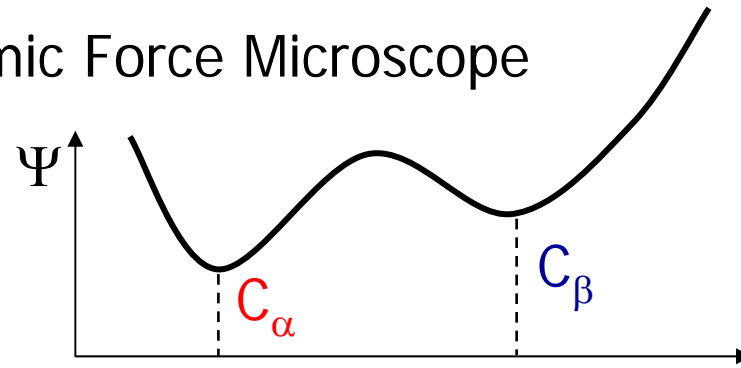
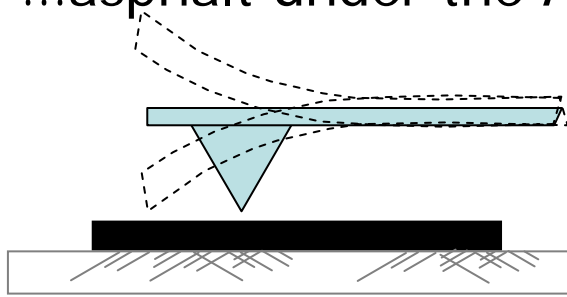

...asphalt under the Atomic Force Microscope

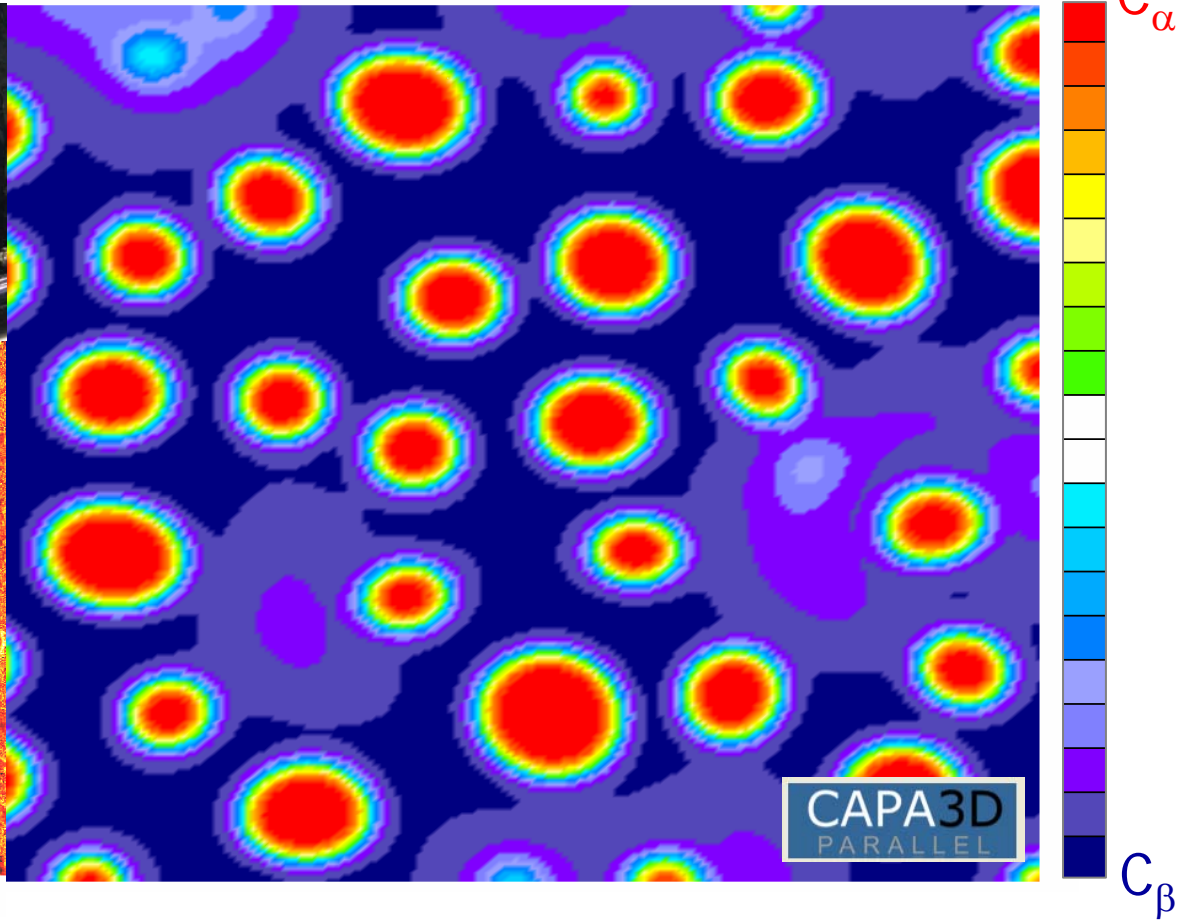
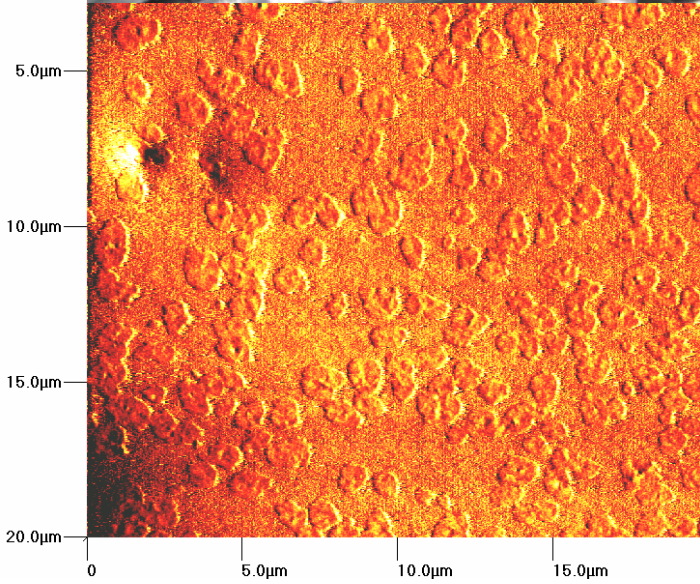
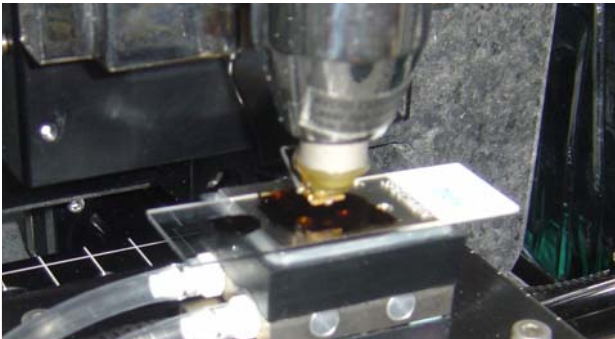
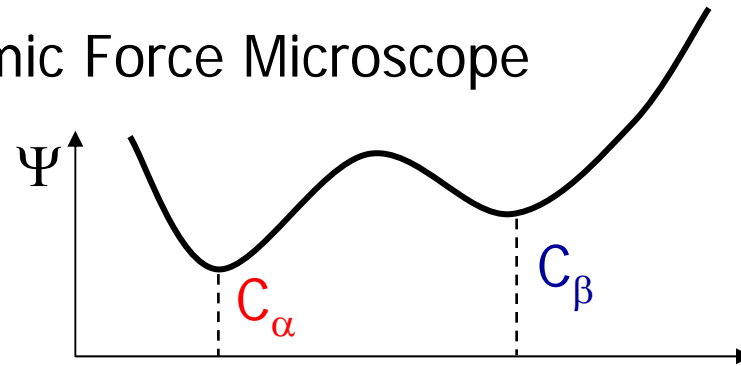
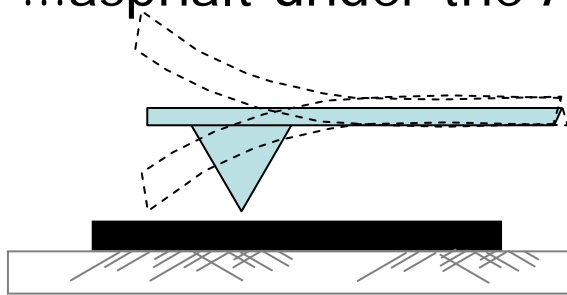

...asphalt under the Atomic Force Microscope

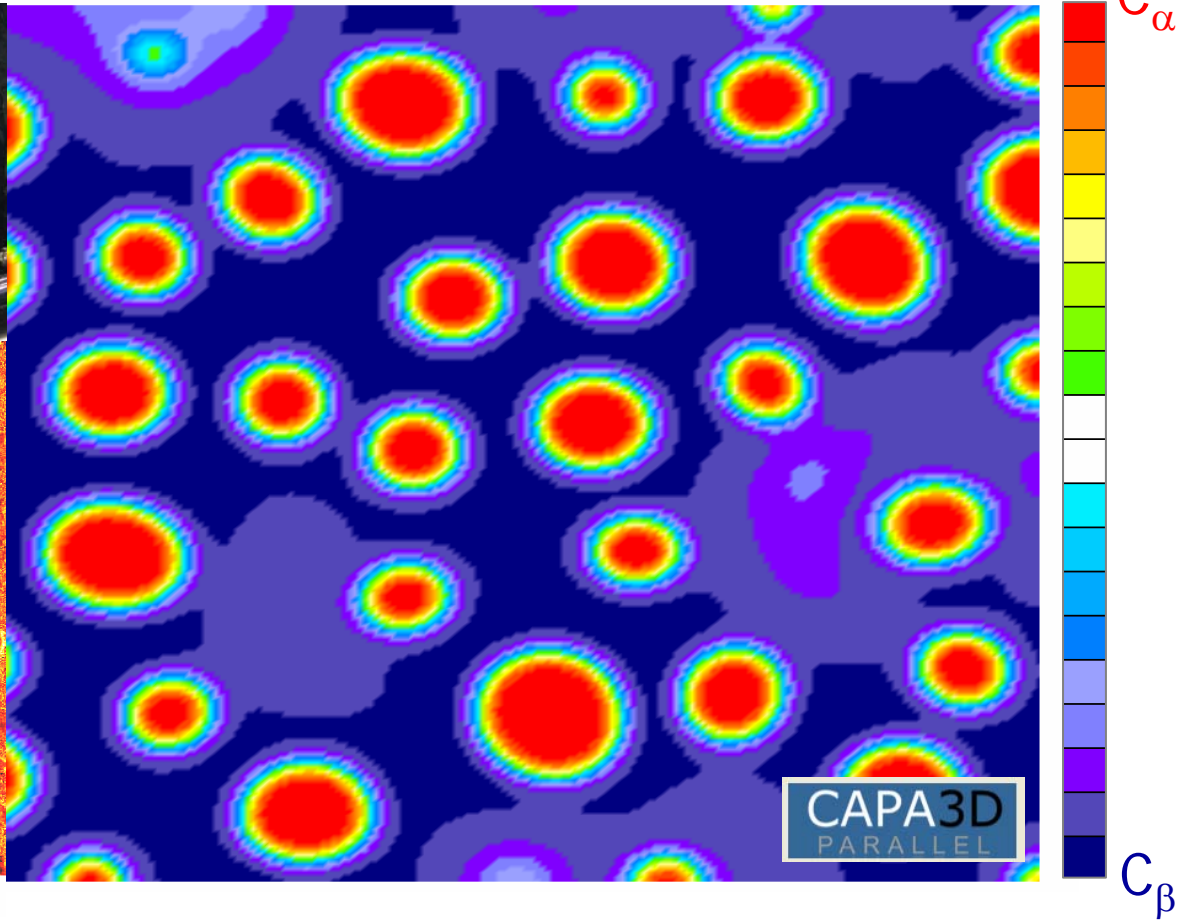
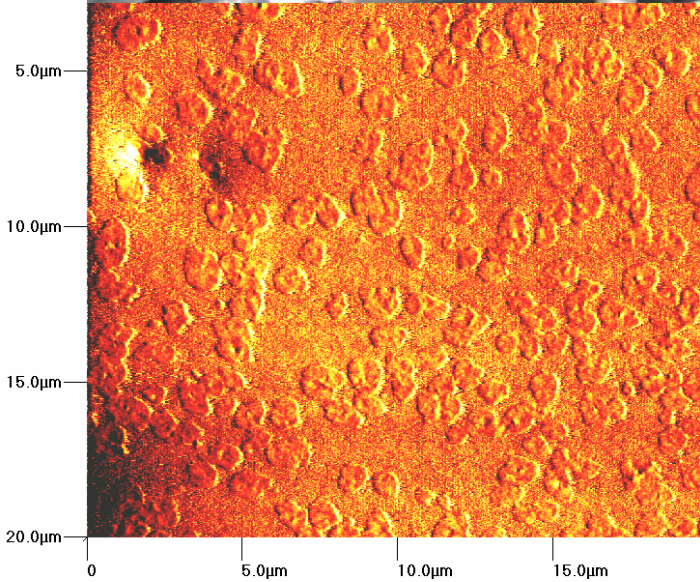
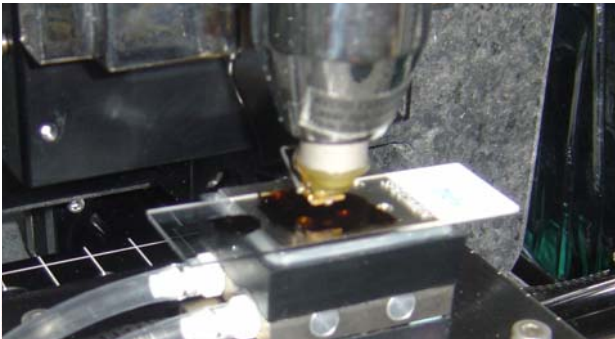
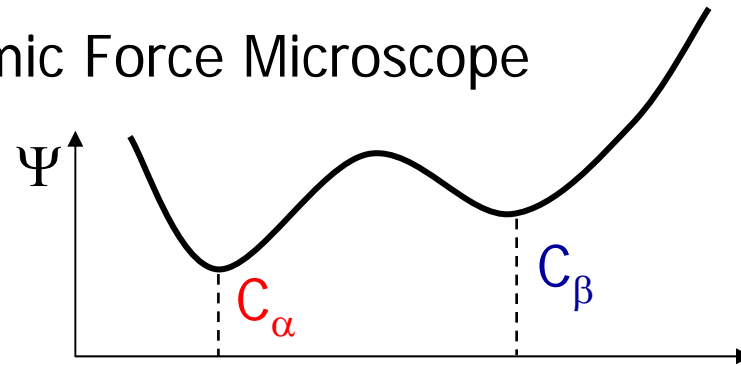
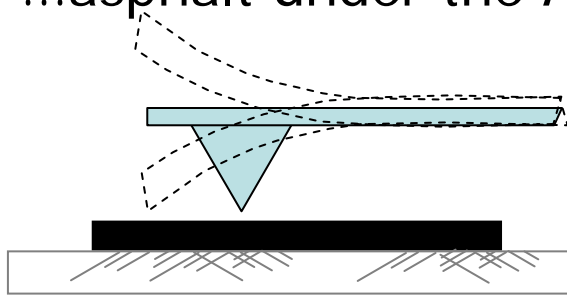

...asphalt under the Atomic Force Microscope

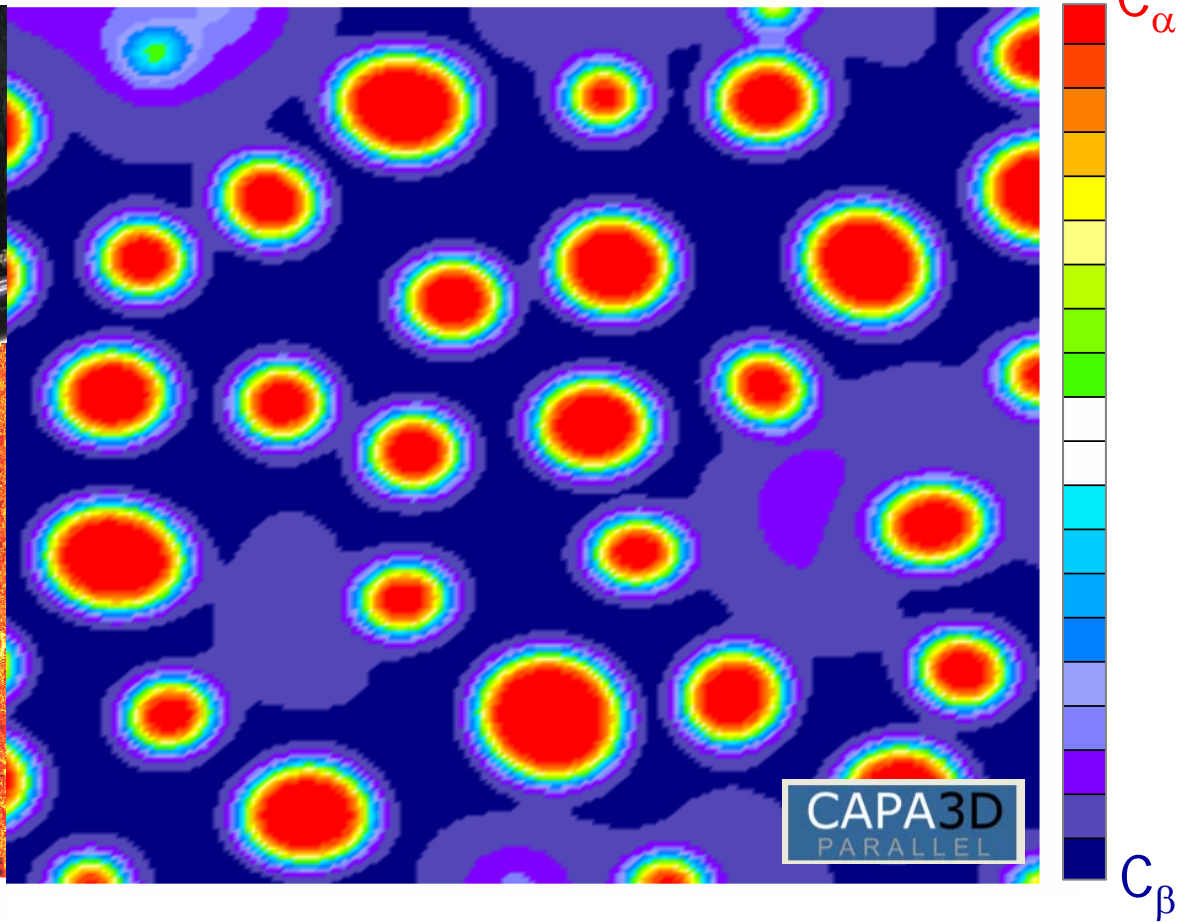
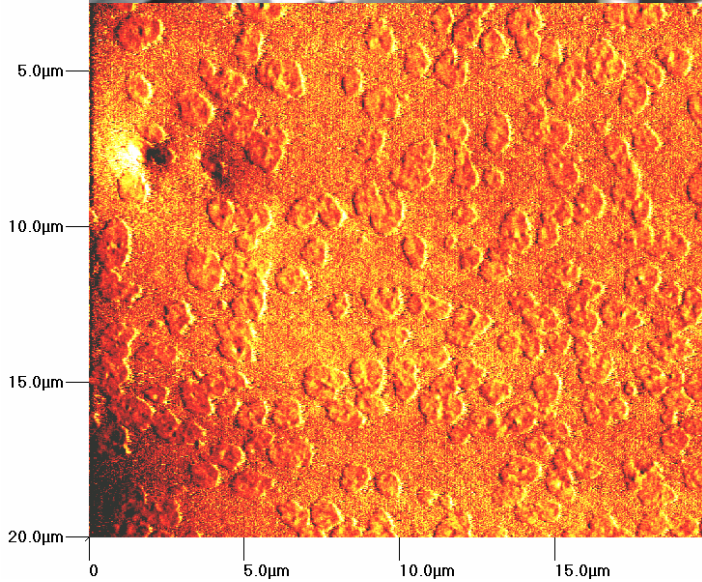
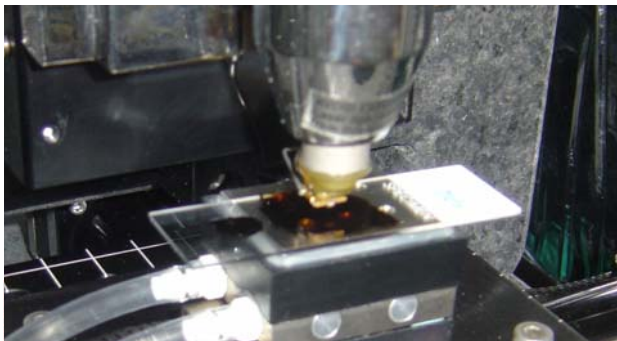
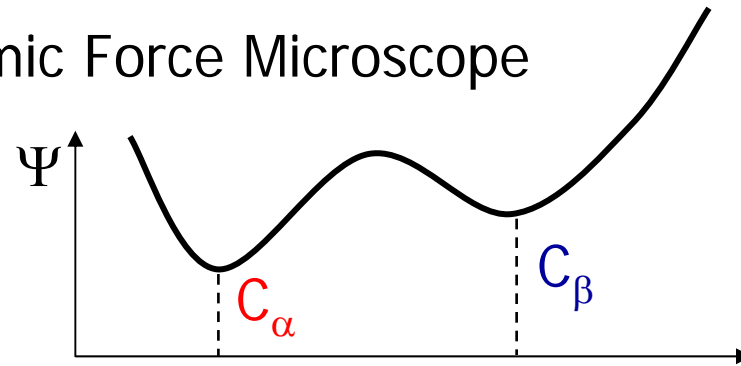
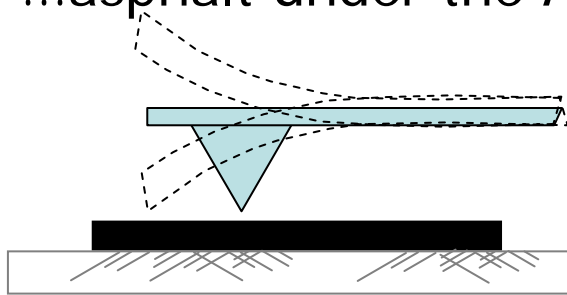

...asphalt under the Atomic Force Microscope

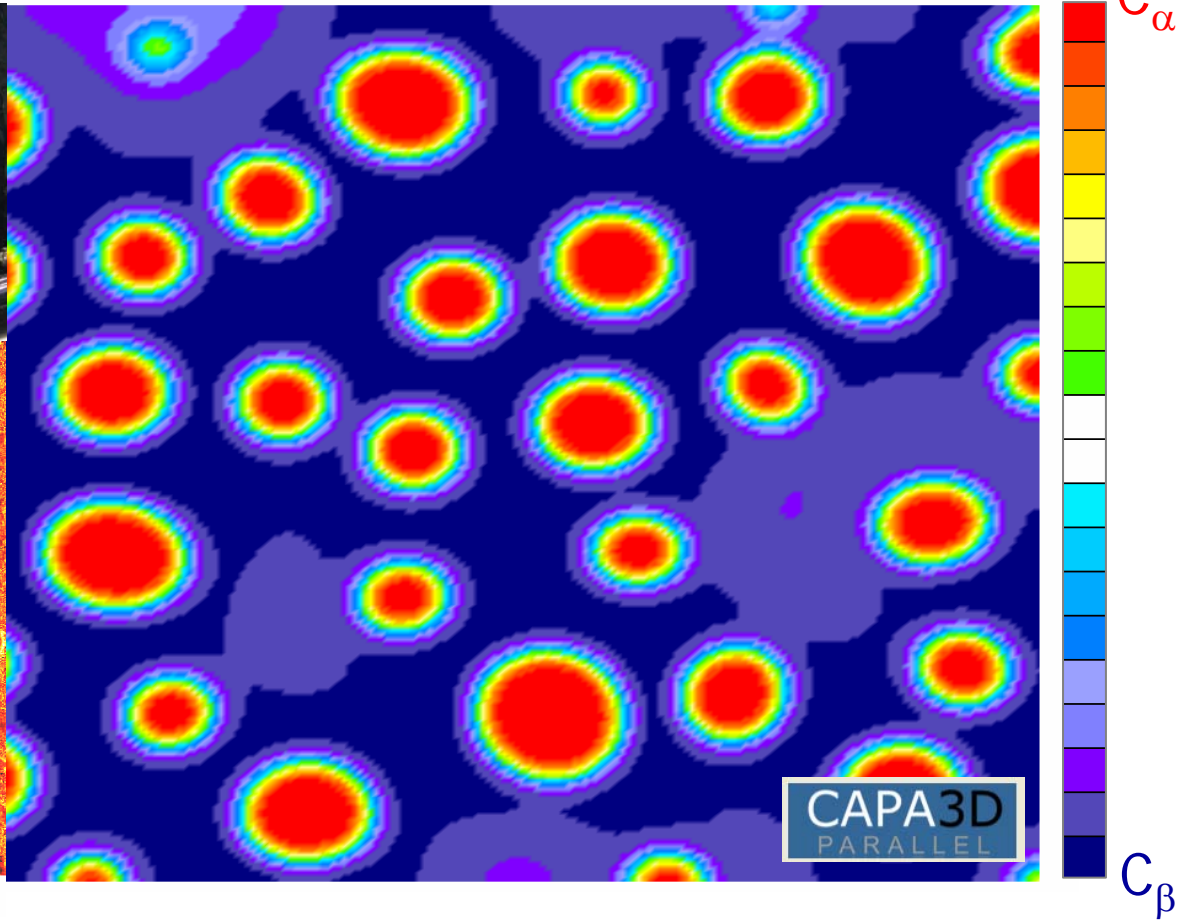
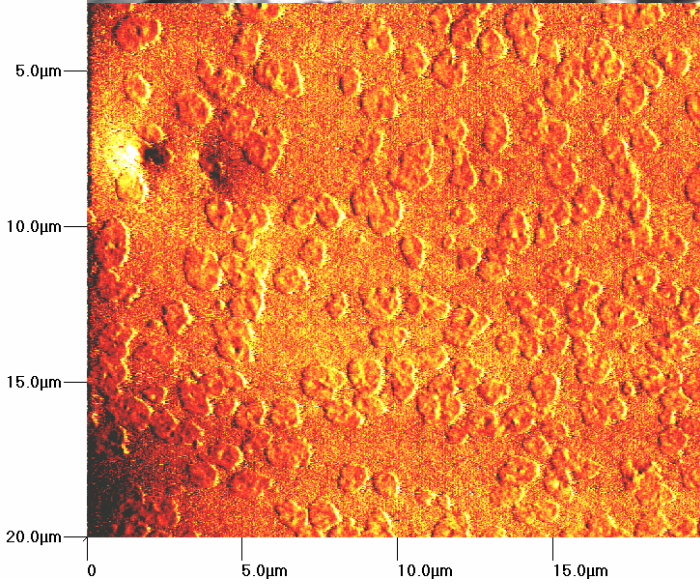
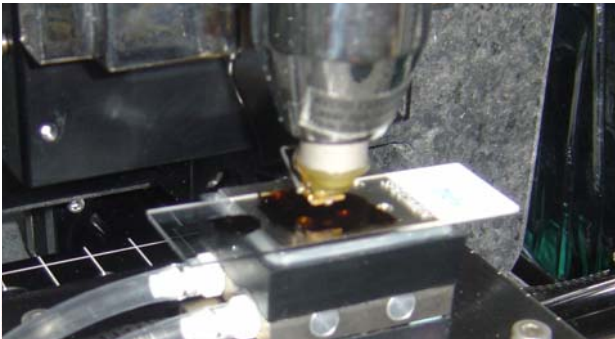
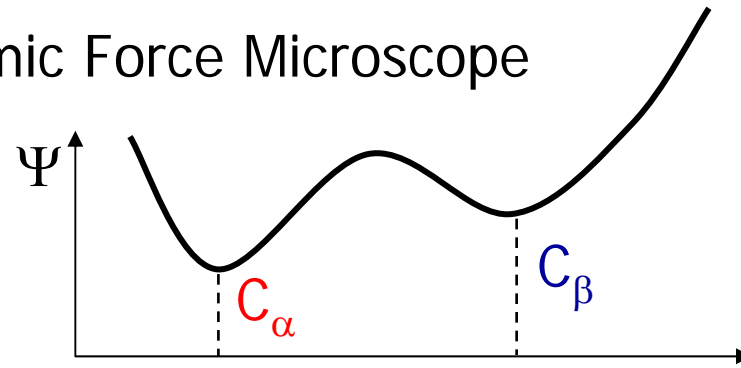
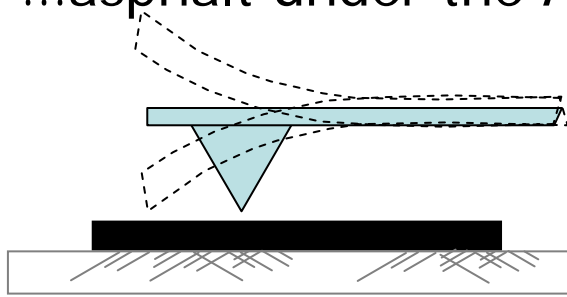

...asphalt under the Atomic Force Microscope

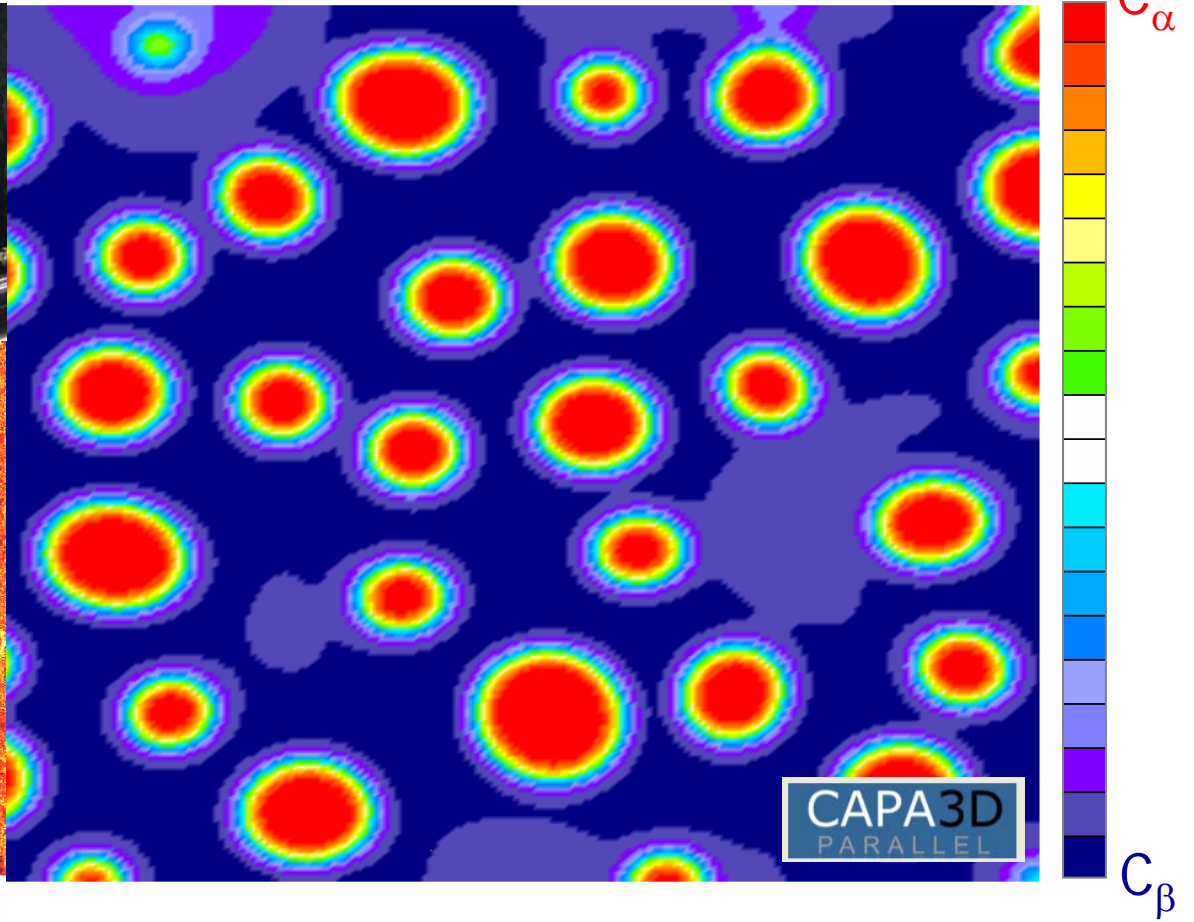
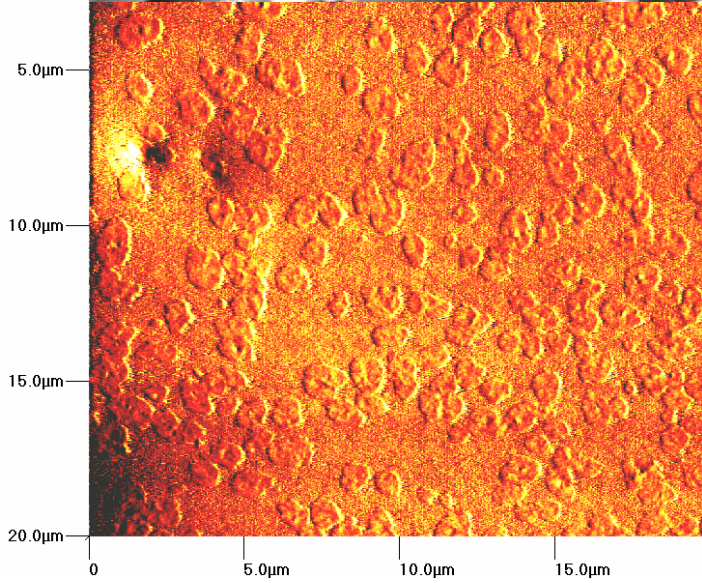
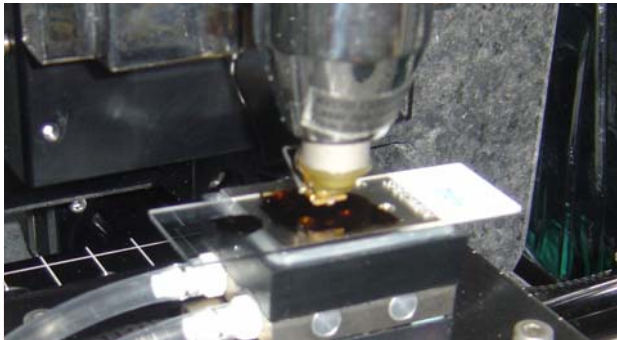
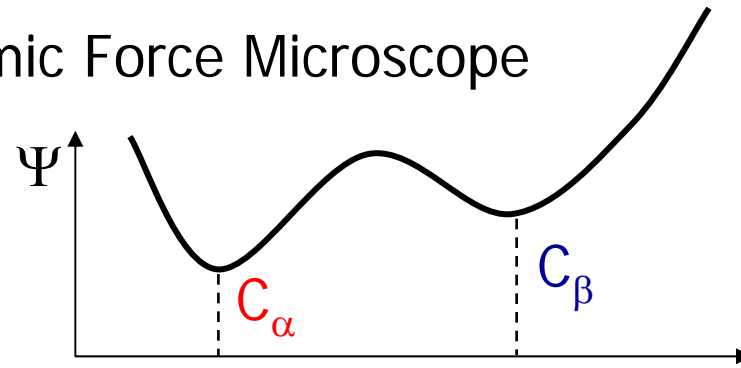
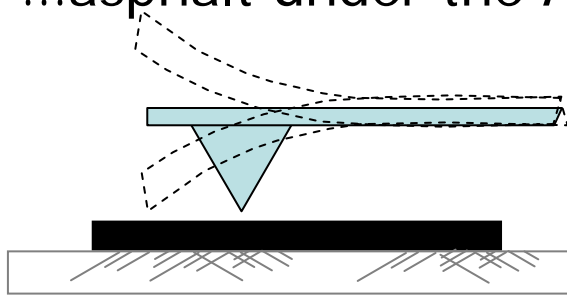

...asphalt under the Atomic Force Microscope

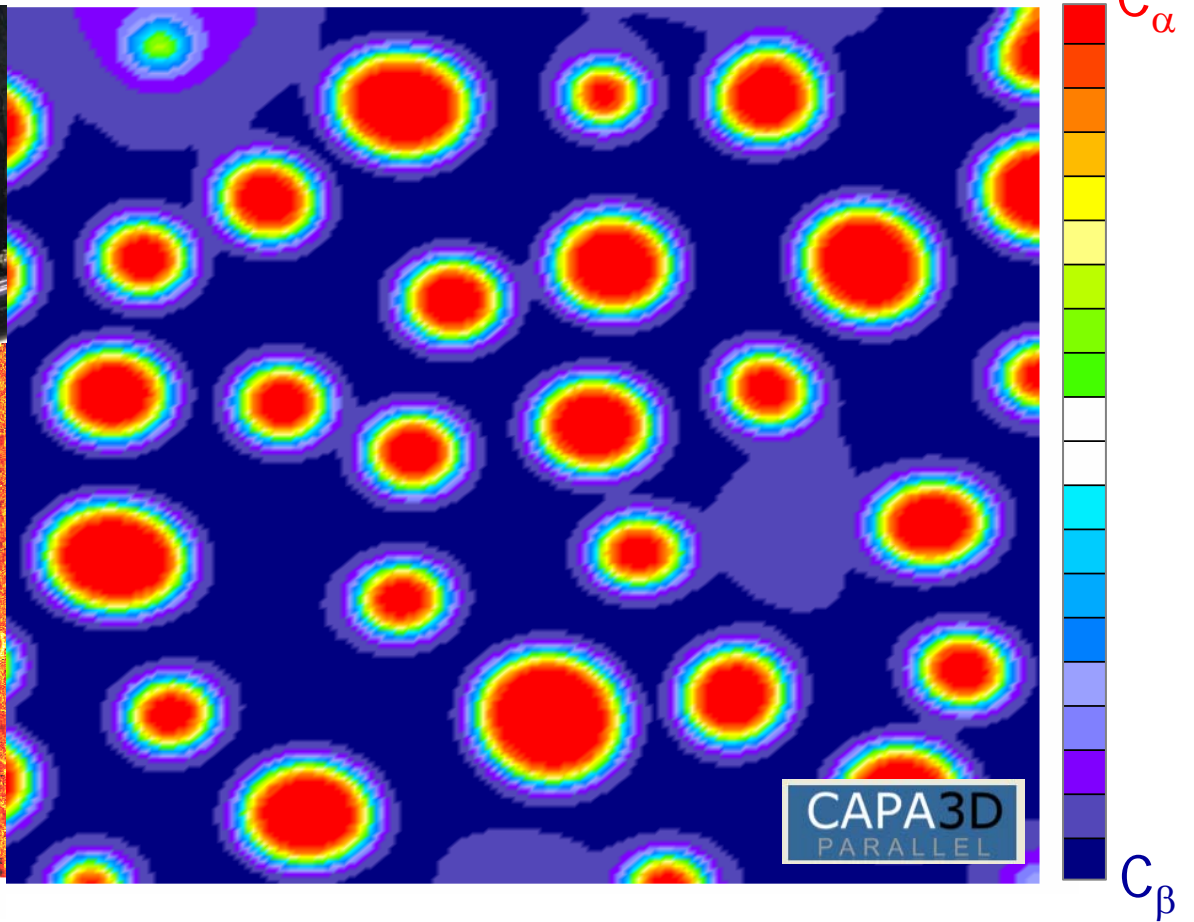
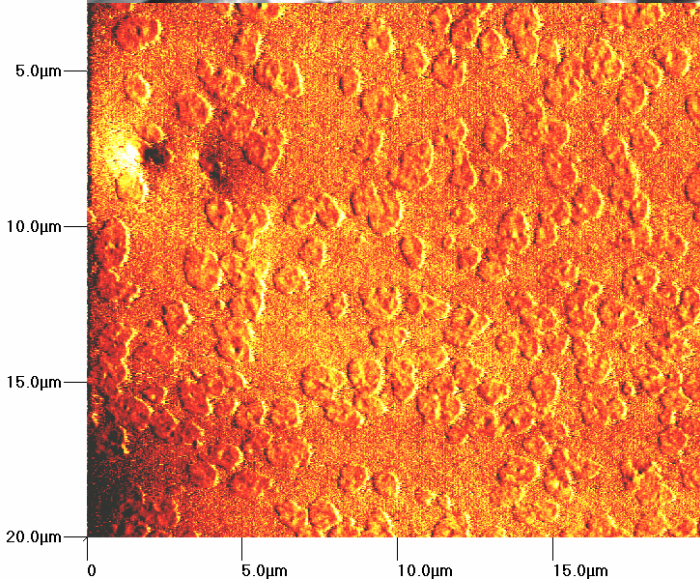
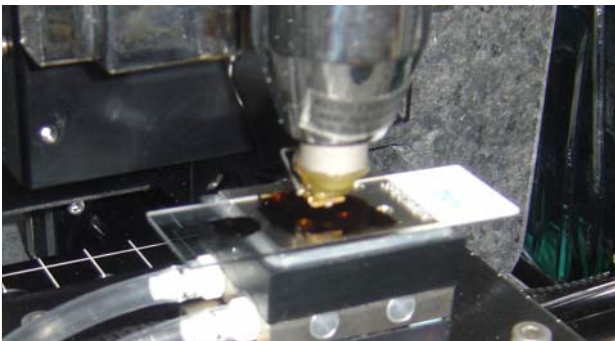
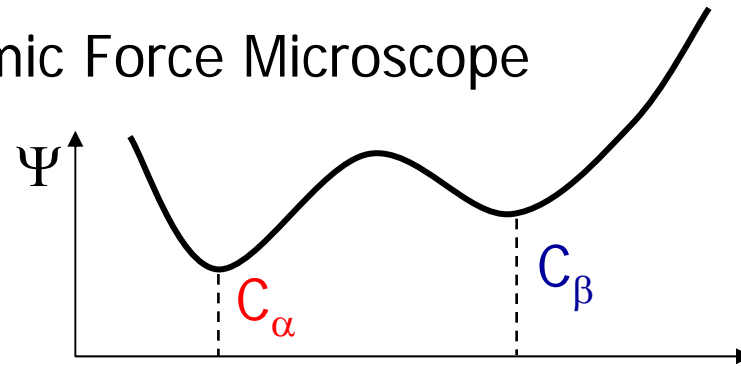
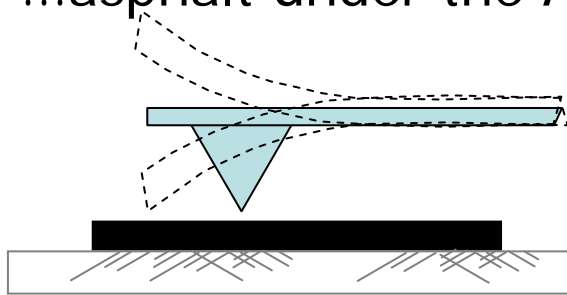

...asphalt under the Atomic Force Microscope

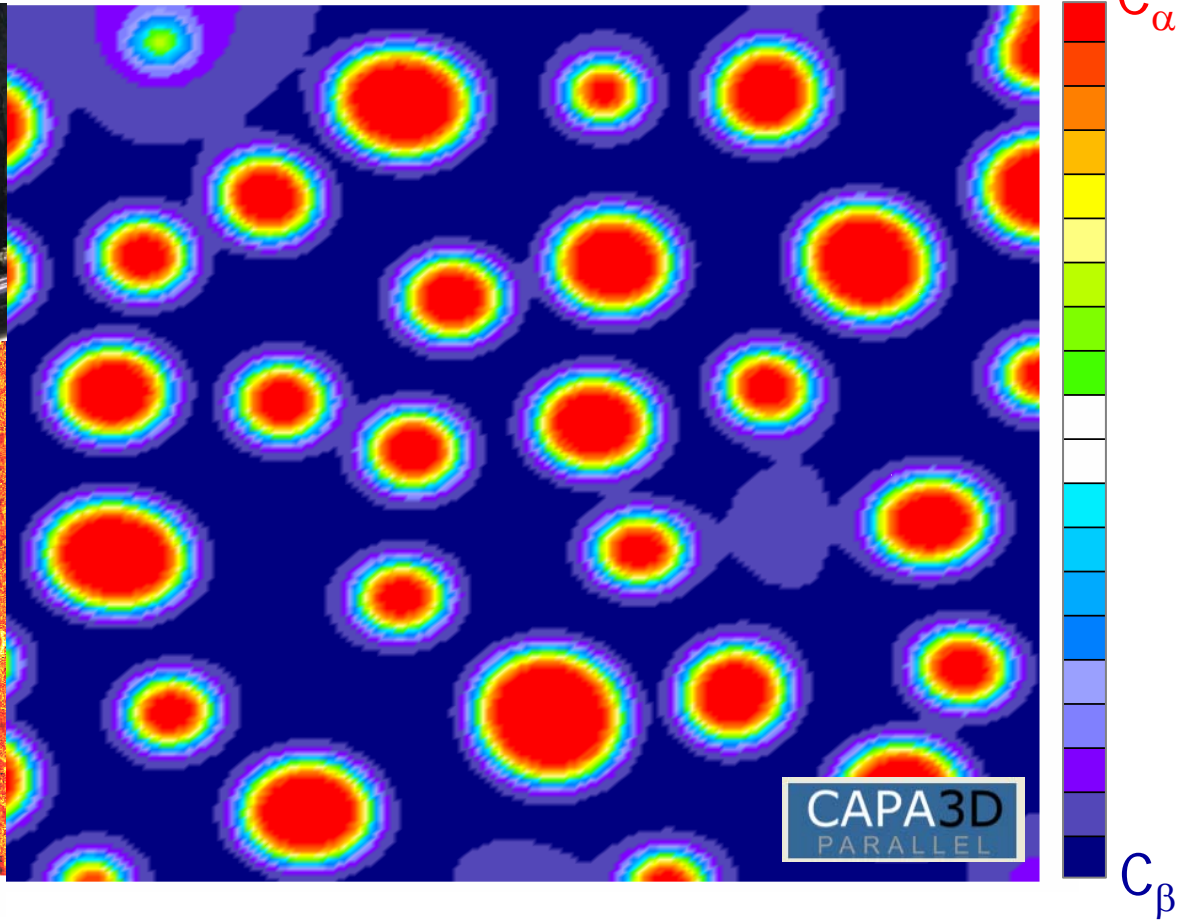
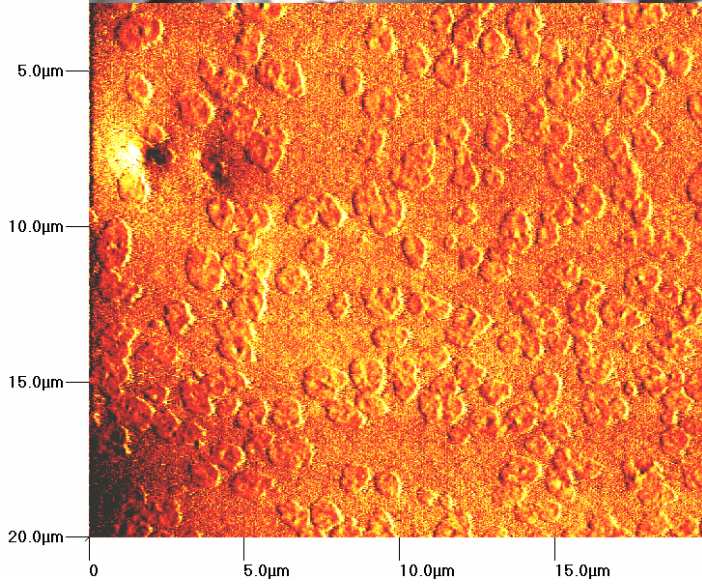
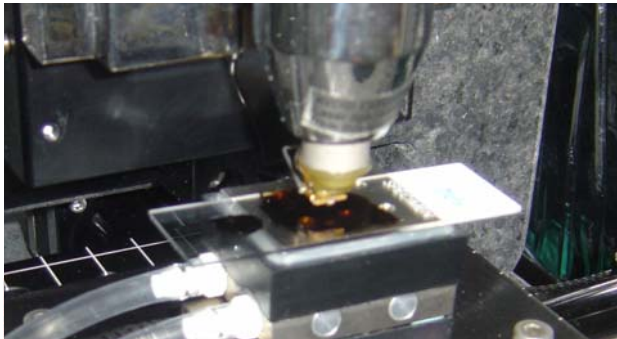
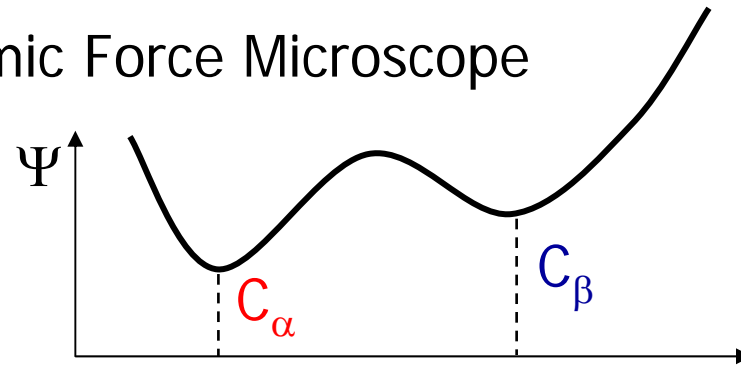
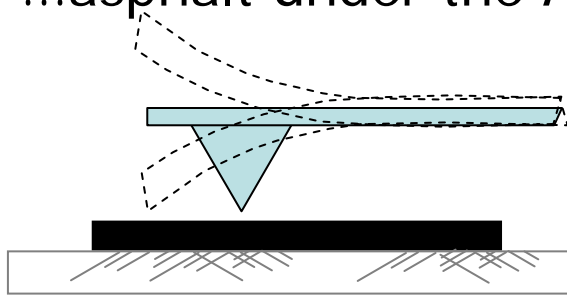

...asphalt under the Atomic Force Microscope

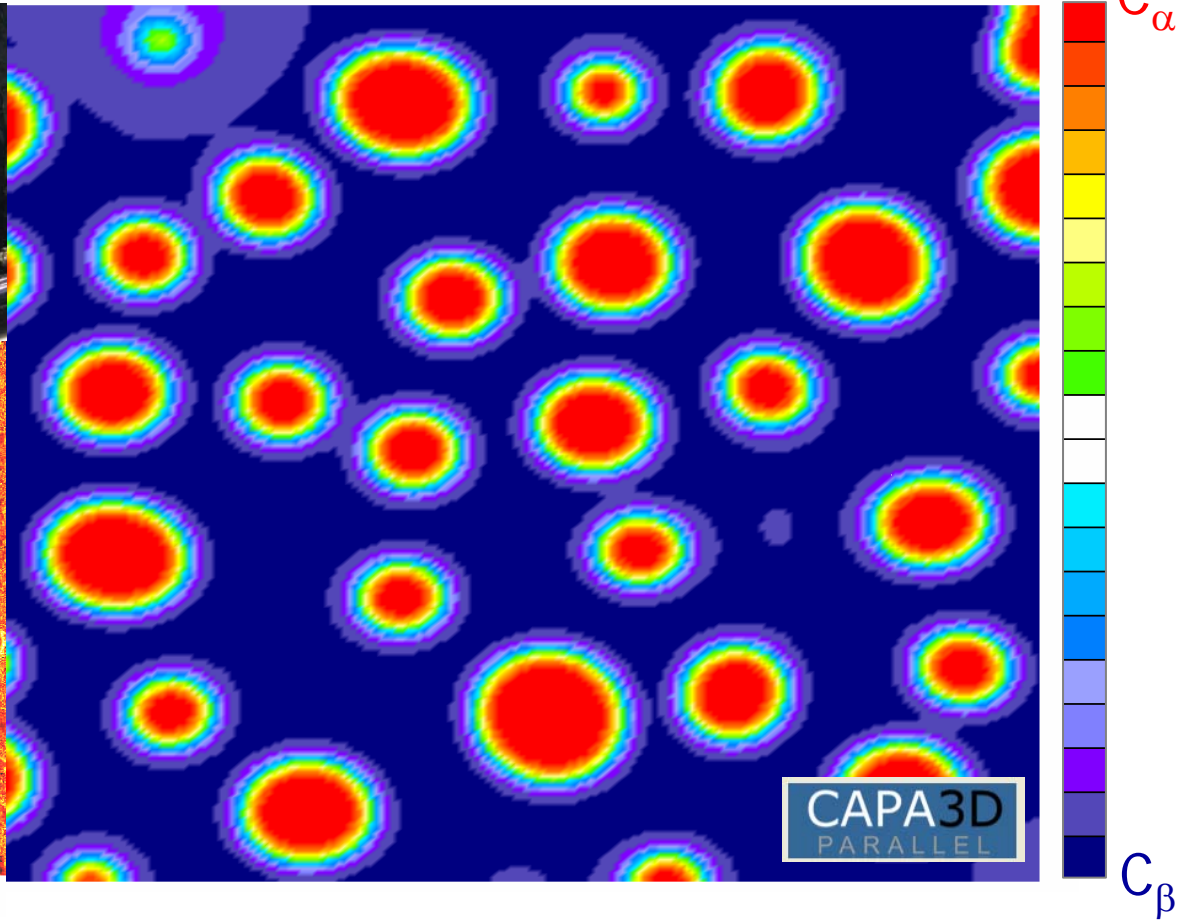
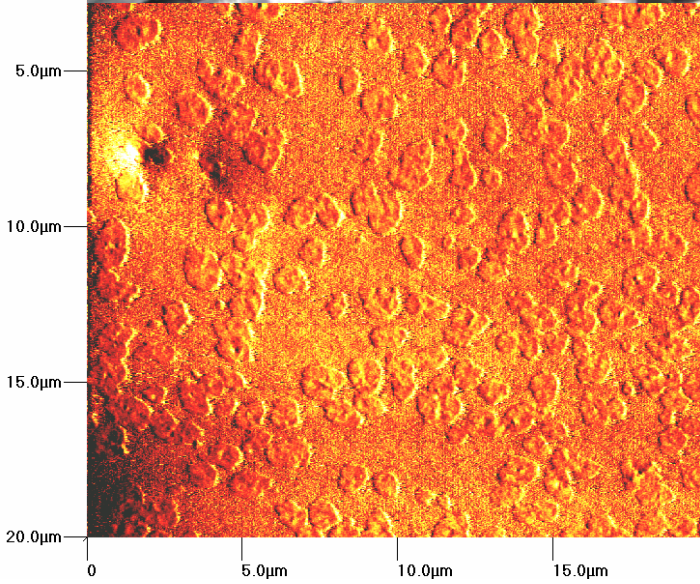
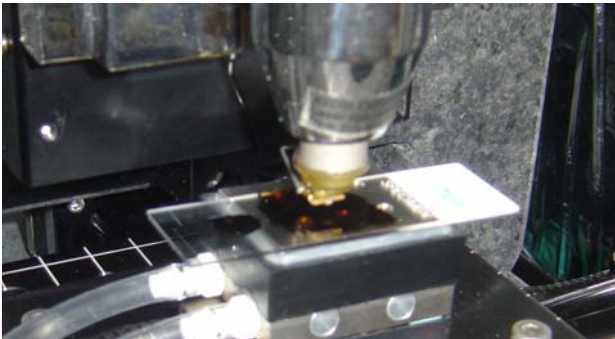
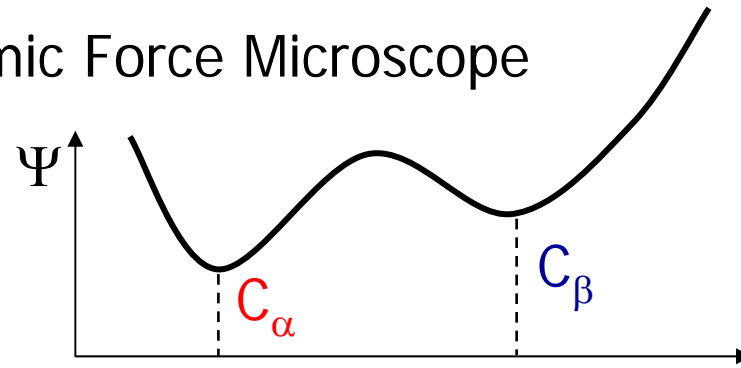
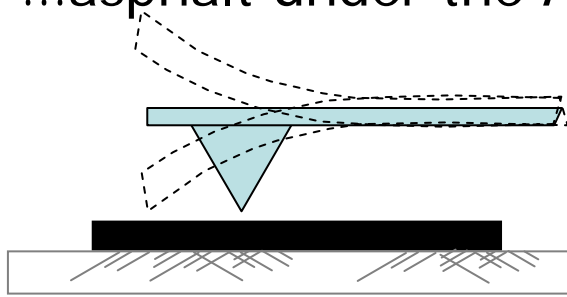

...asphalt under the Atomic Force Microscope

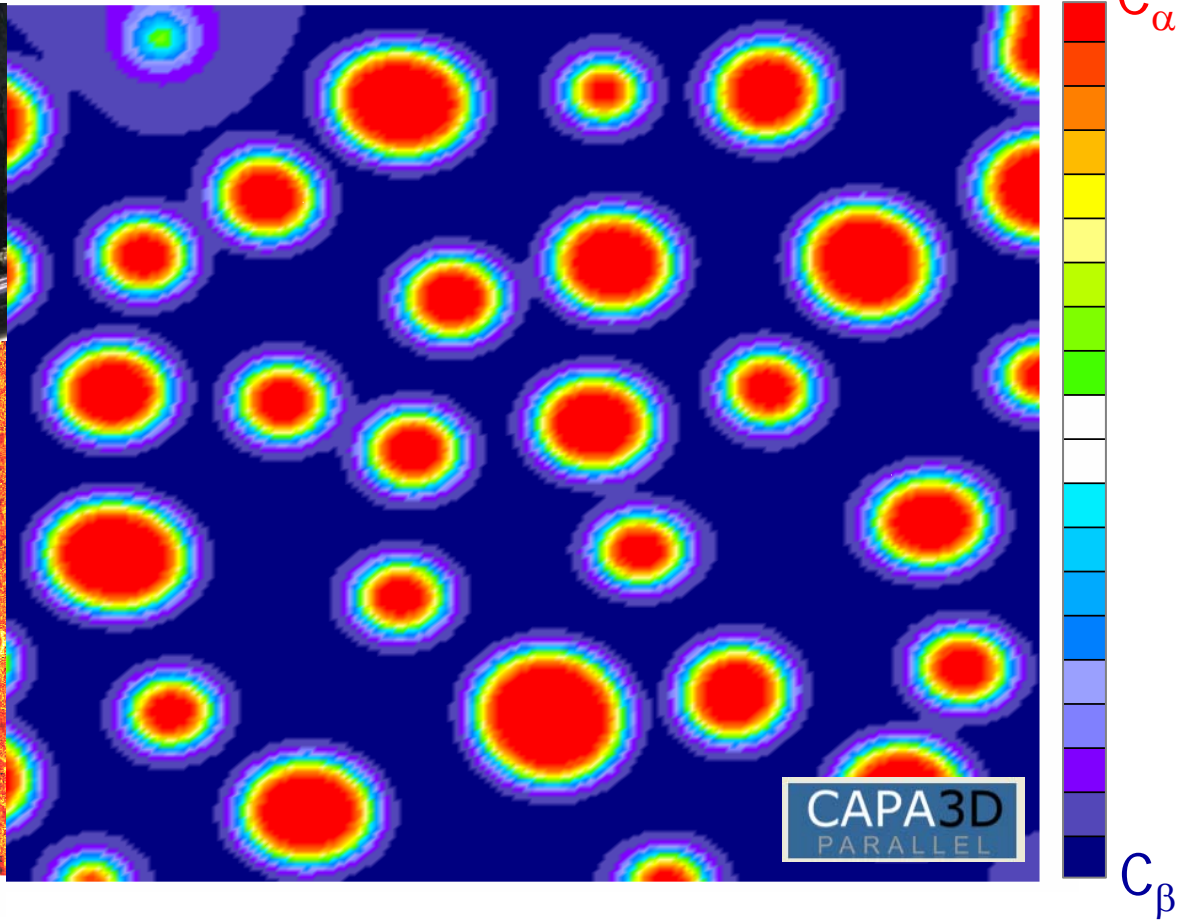
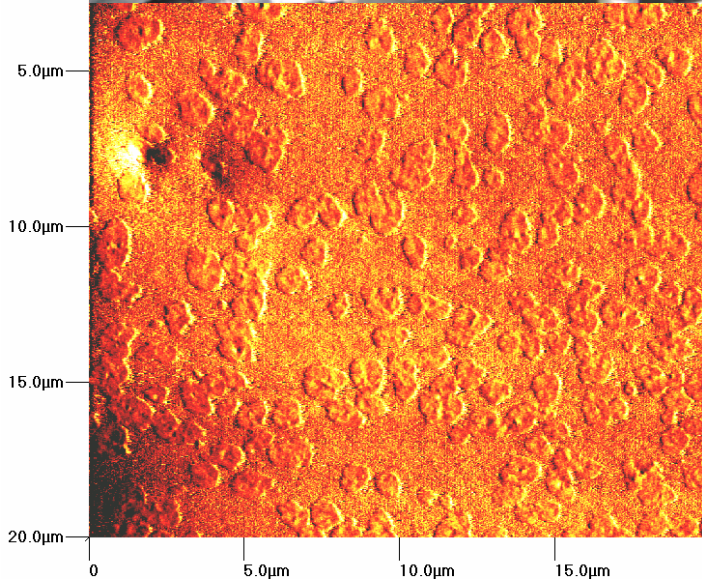
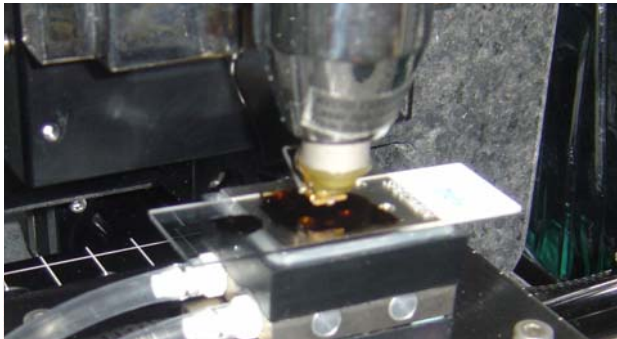
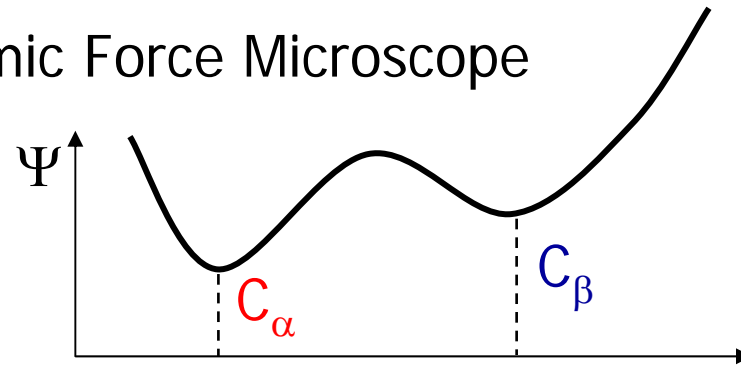
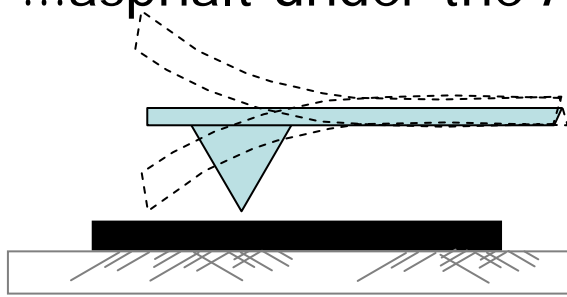

...asphalt under the Atomic Force Microscope

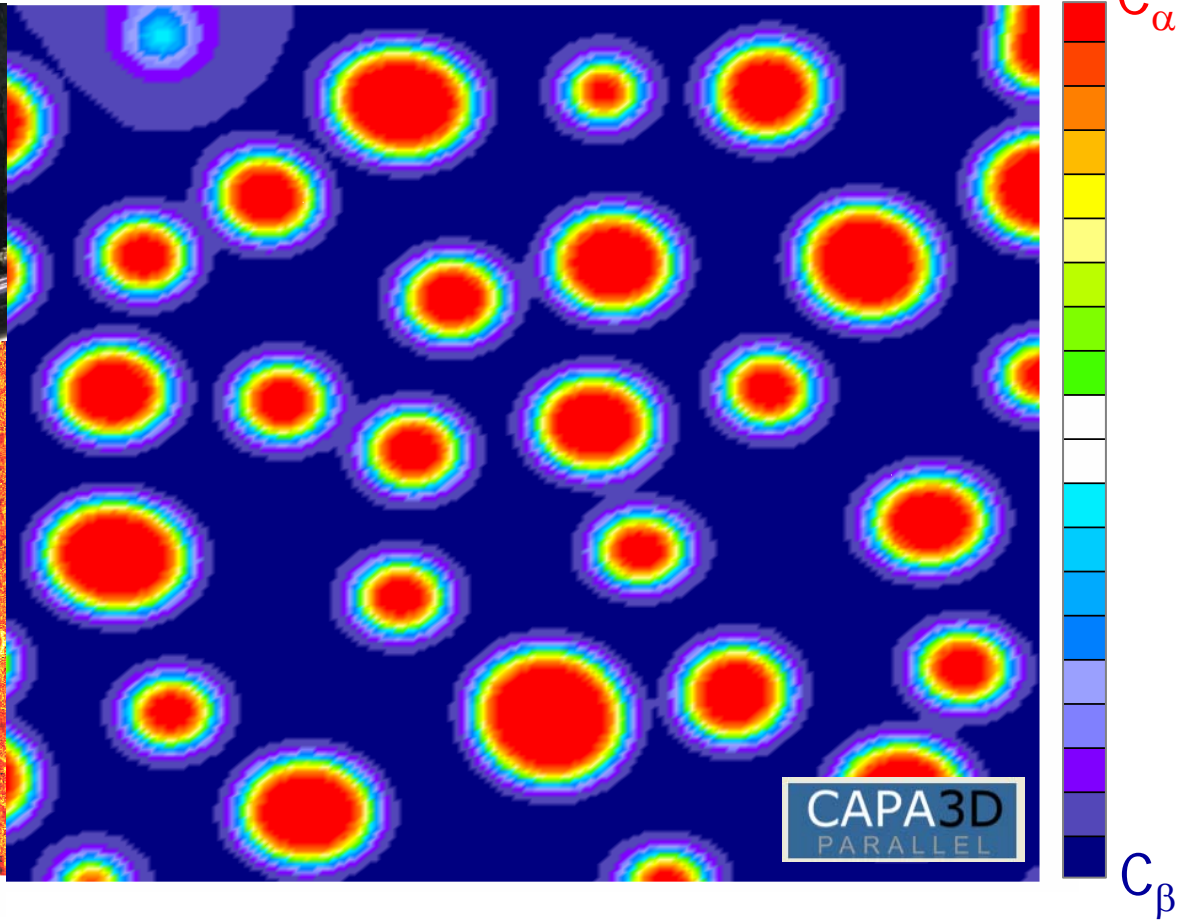
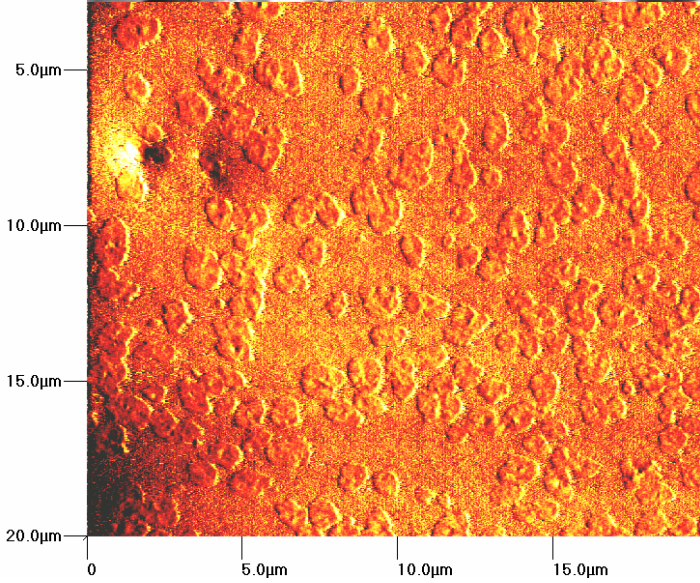
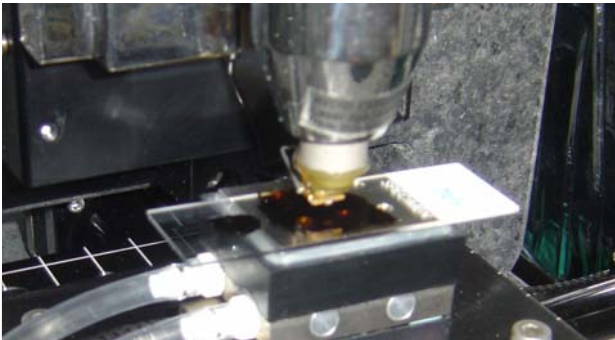
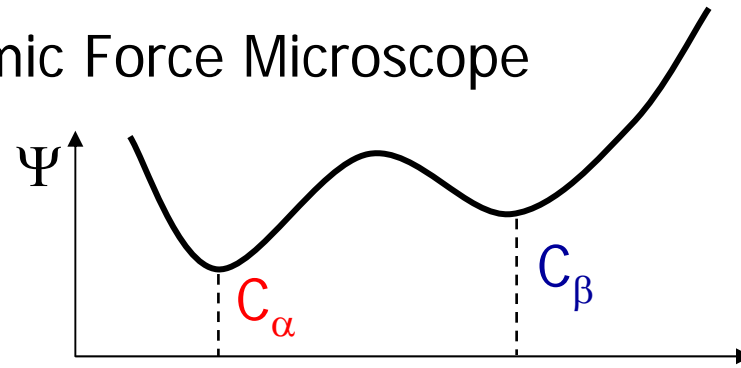
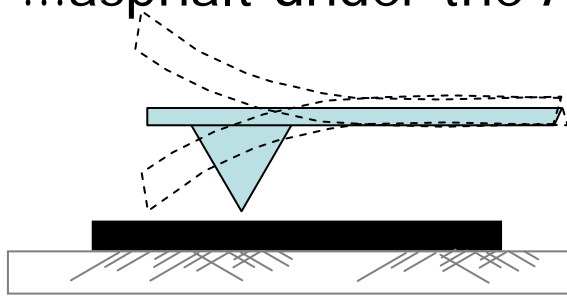

...asphalt under the Atomic Force Microscope

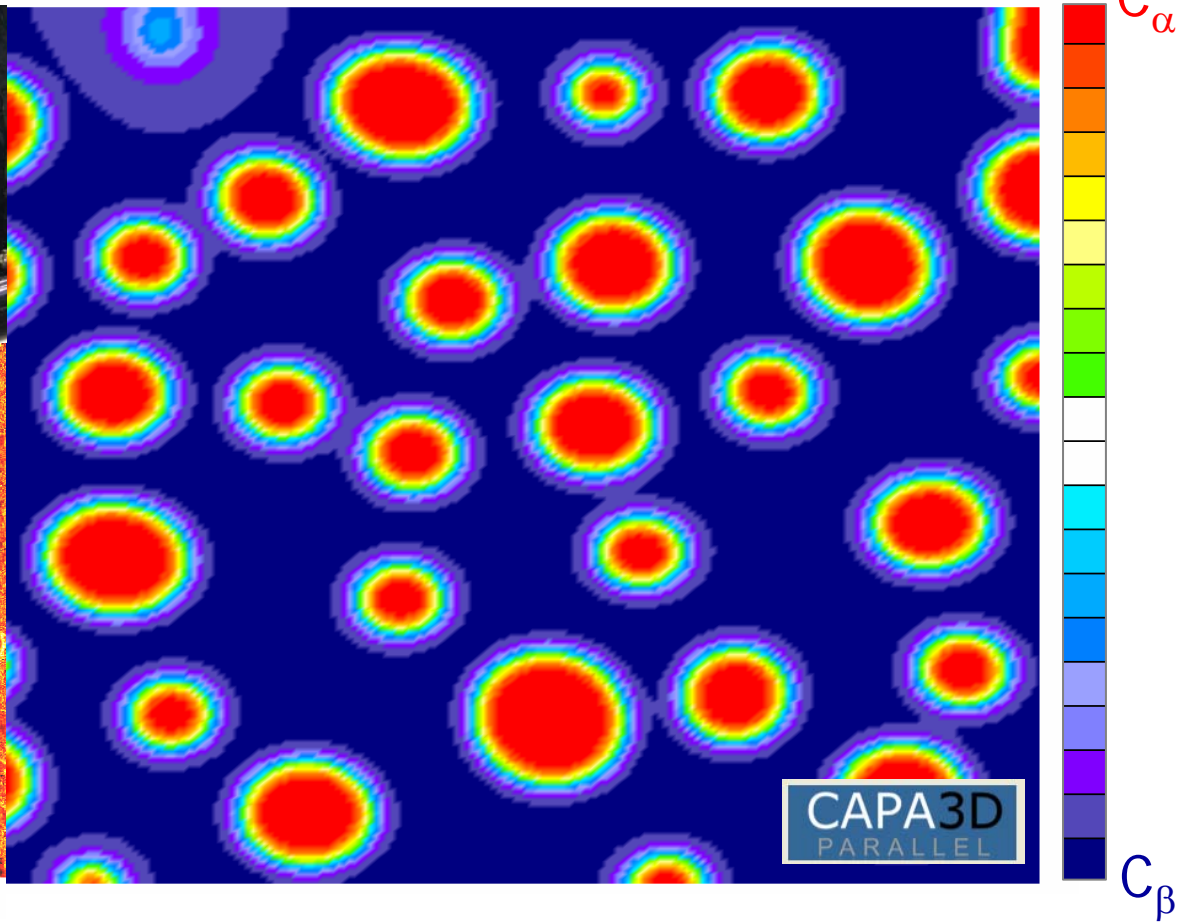
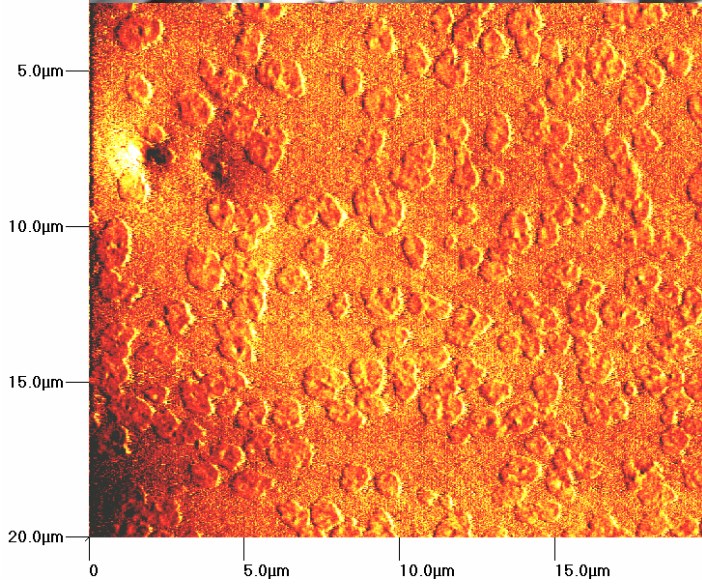
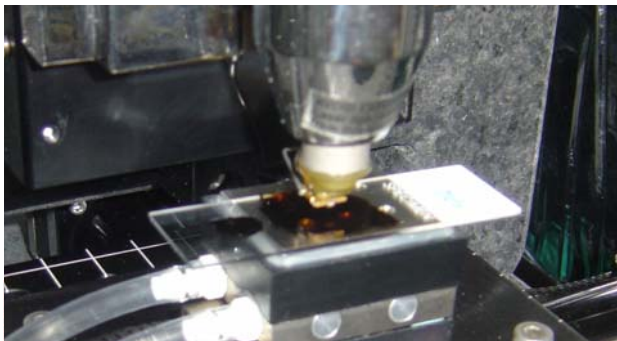
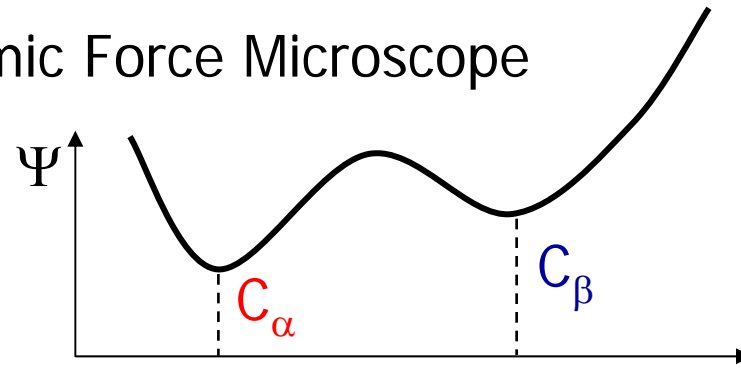
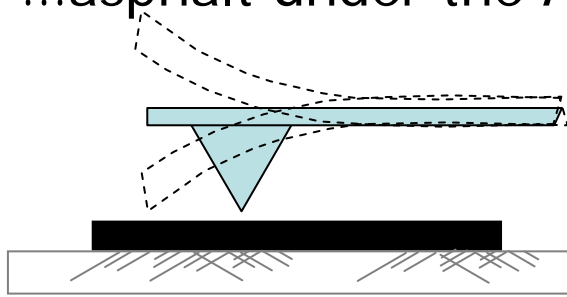

...asphalt under the Atomic Force Microscope

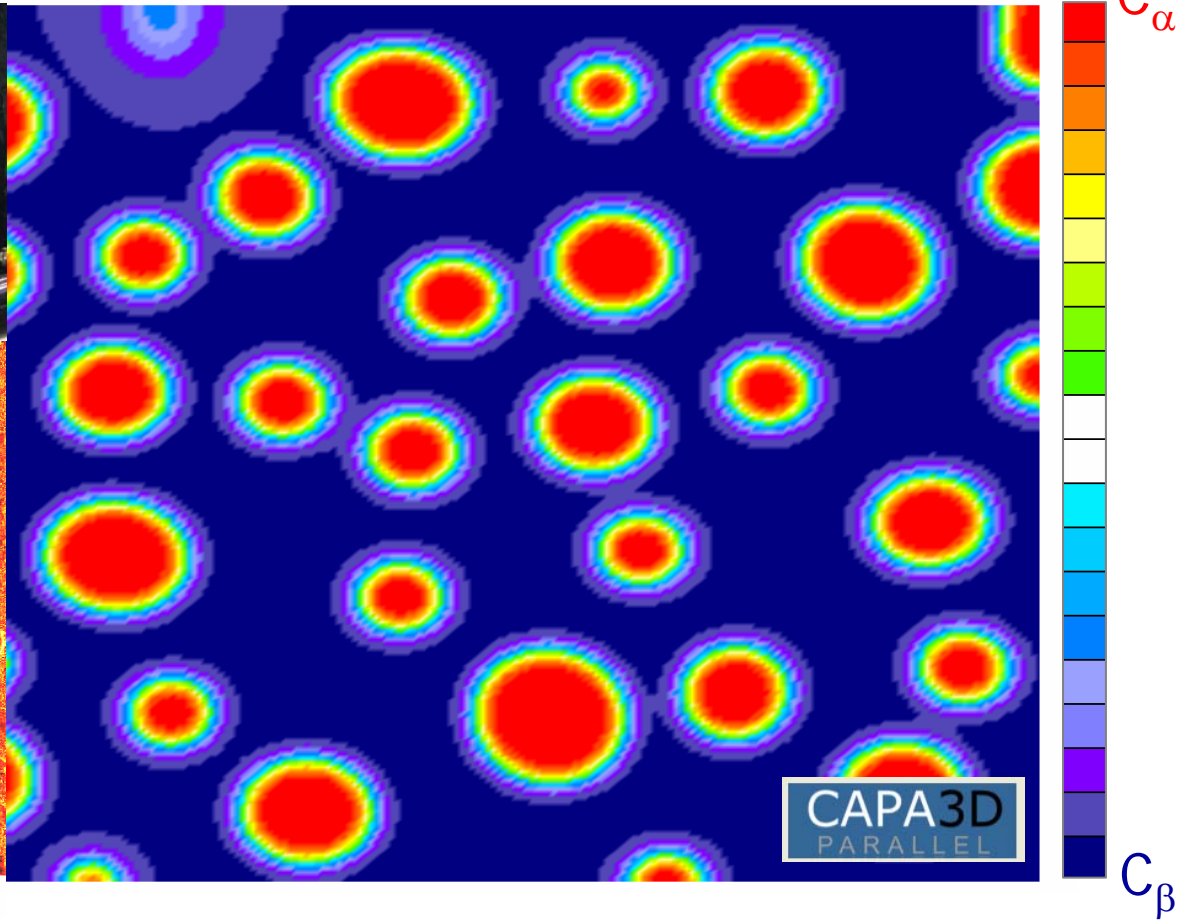
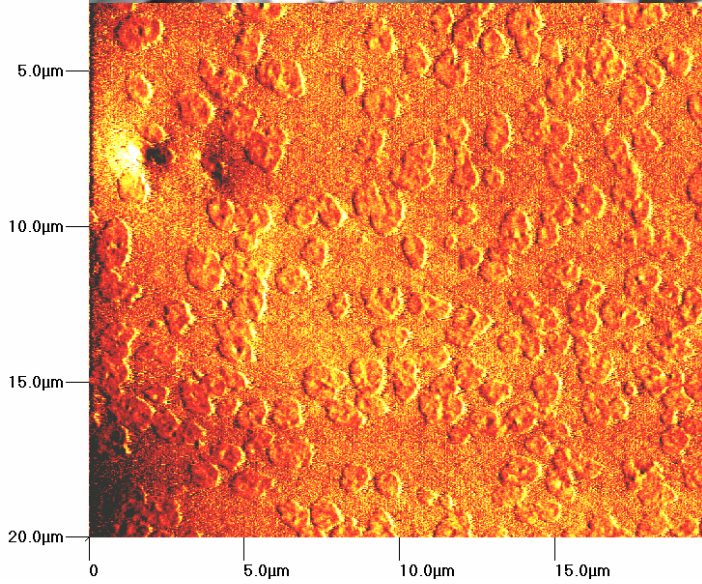
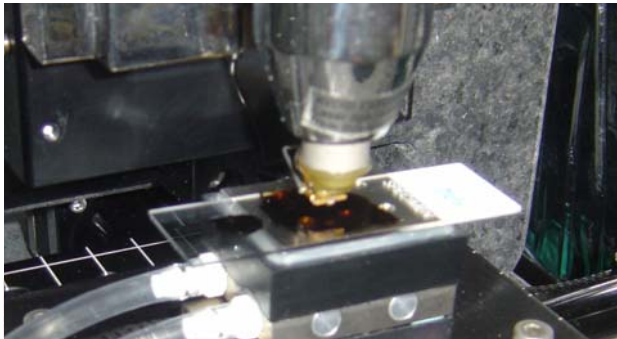
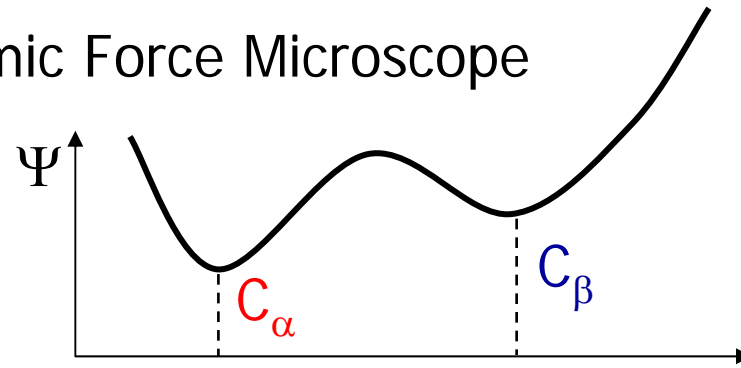
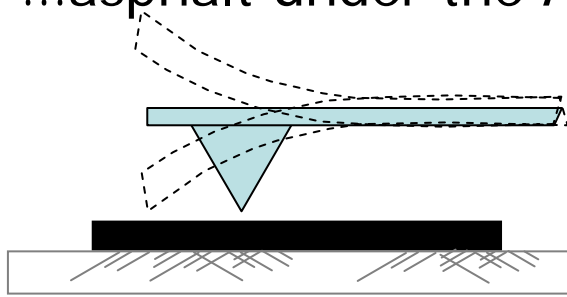

...asphalt under the Atomic Force Microscope

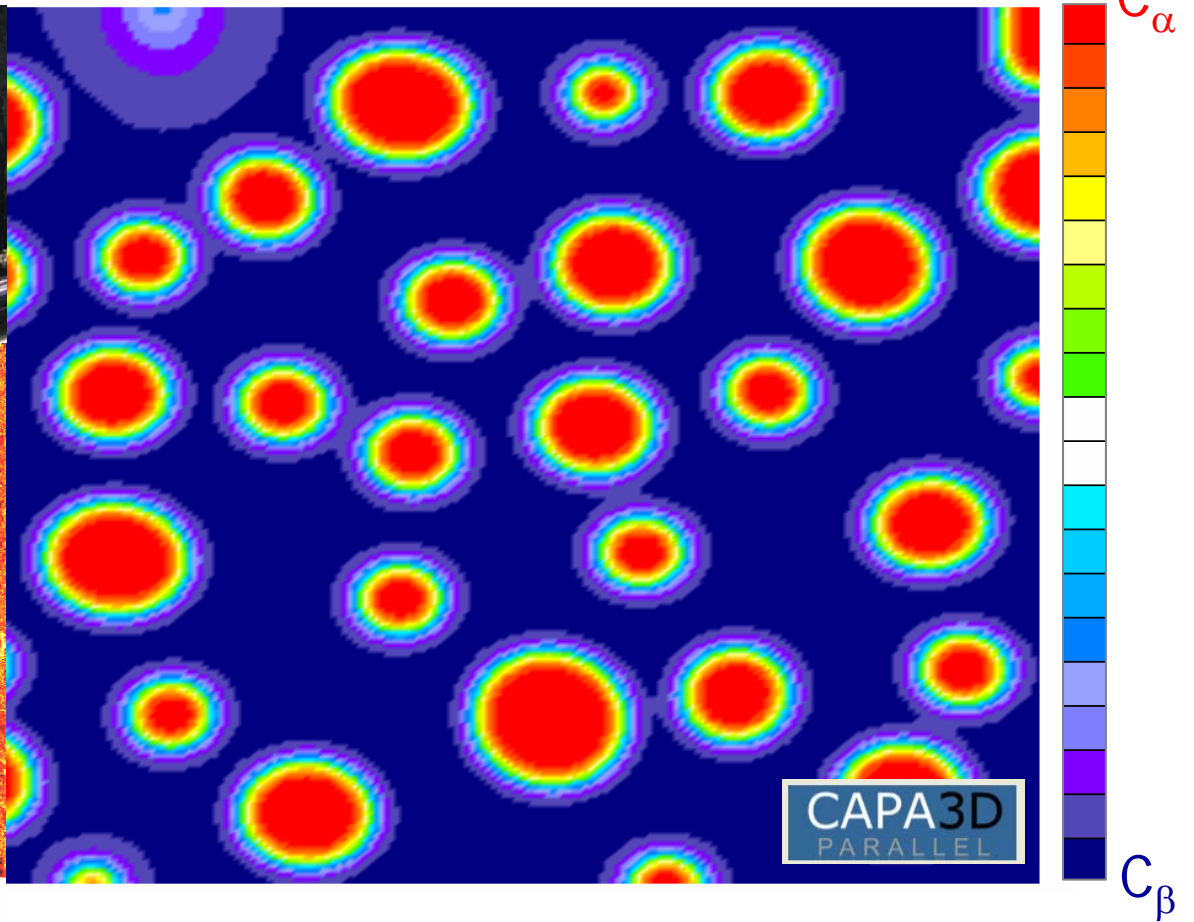
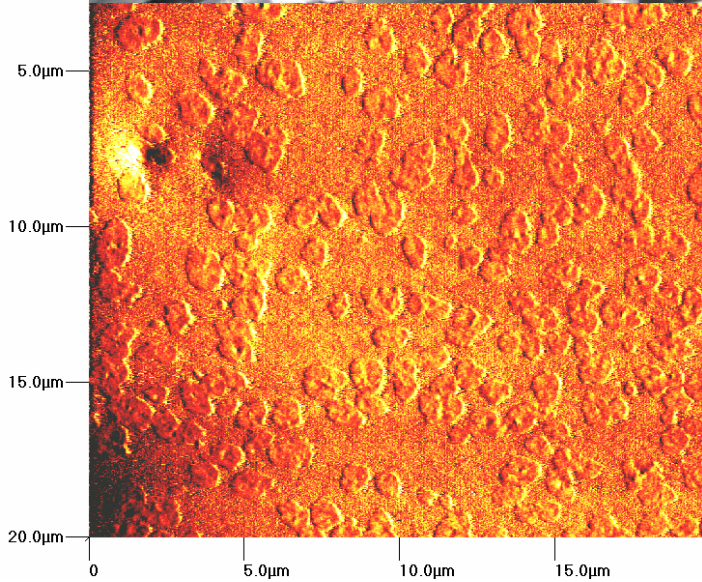
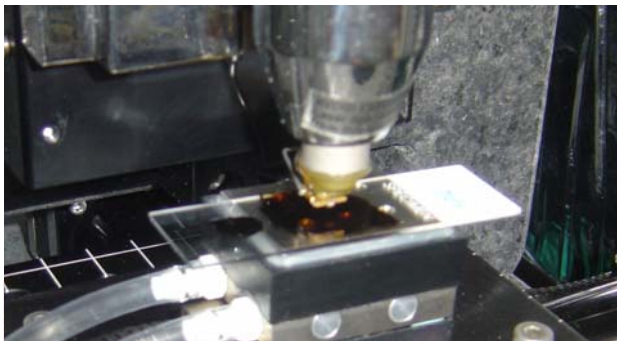
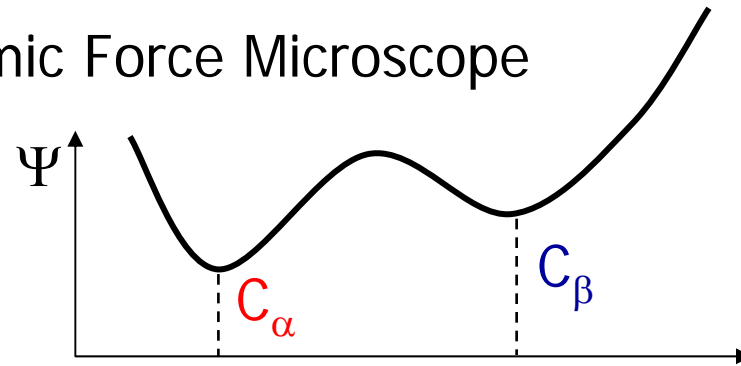
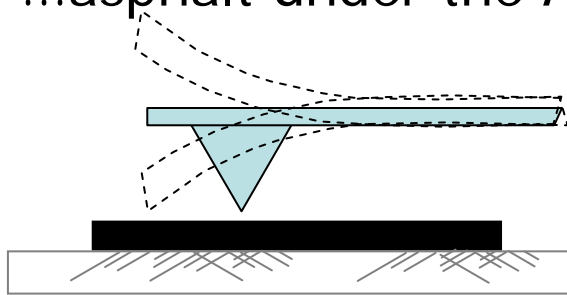

...asphalt under the Atomic Force Microscope

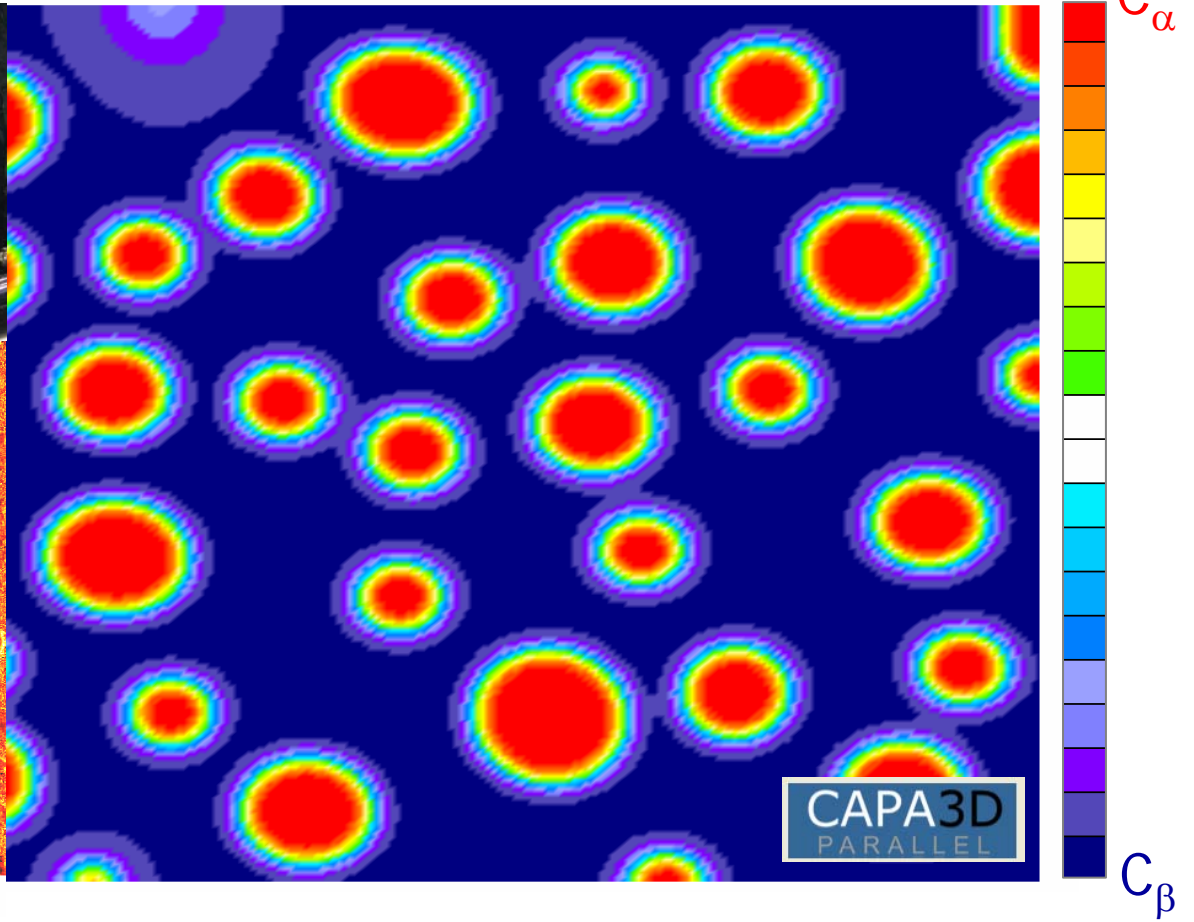
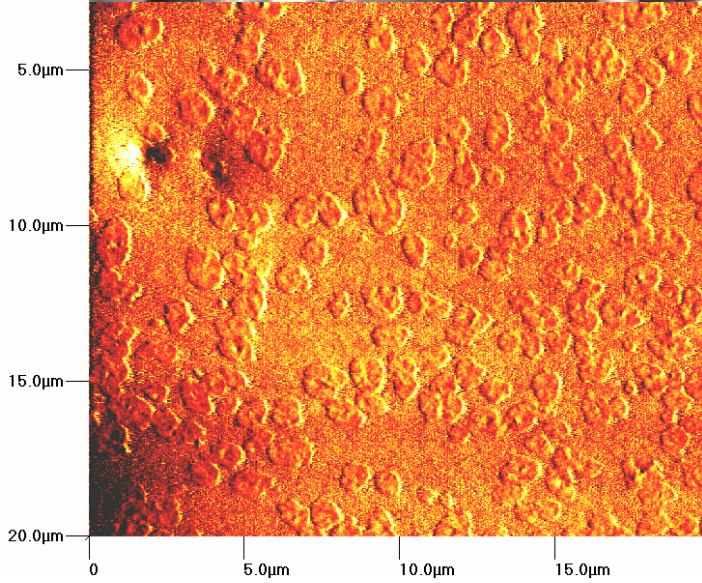
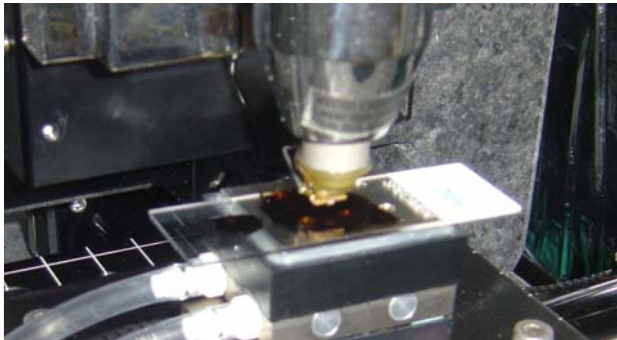
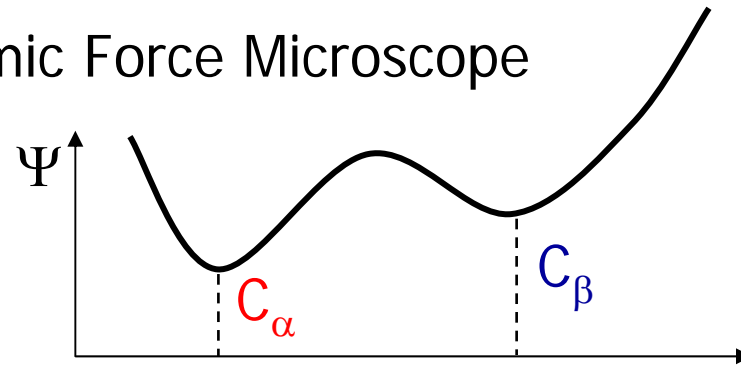
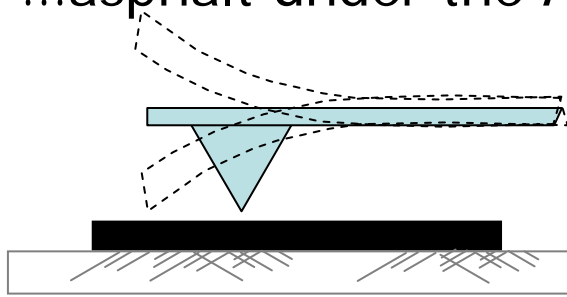

...asphalt under the Atomic Force Microscope

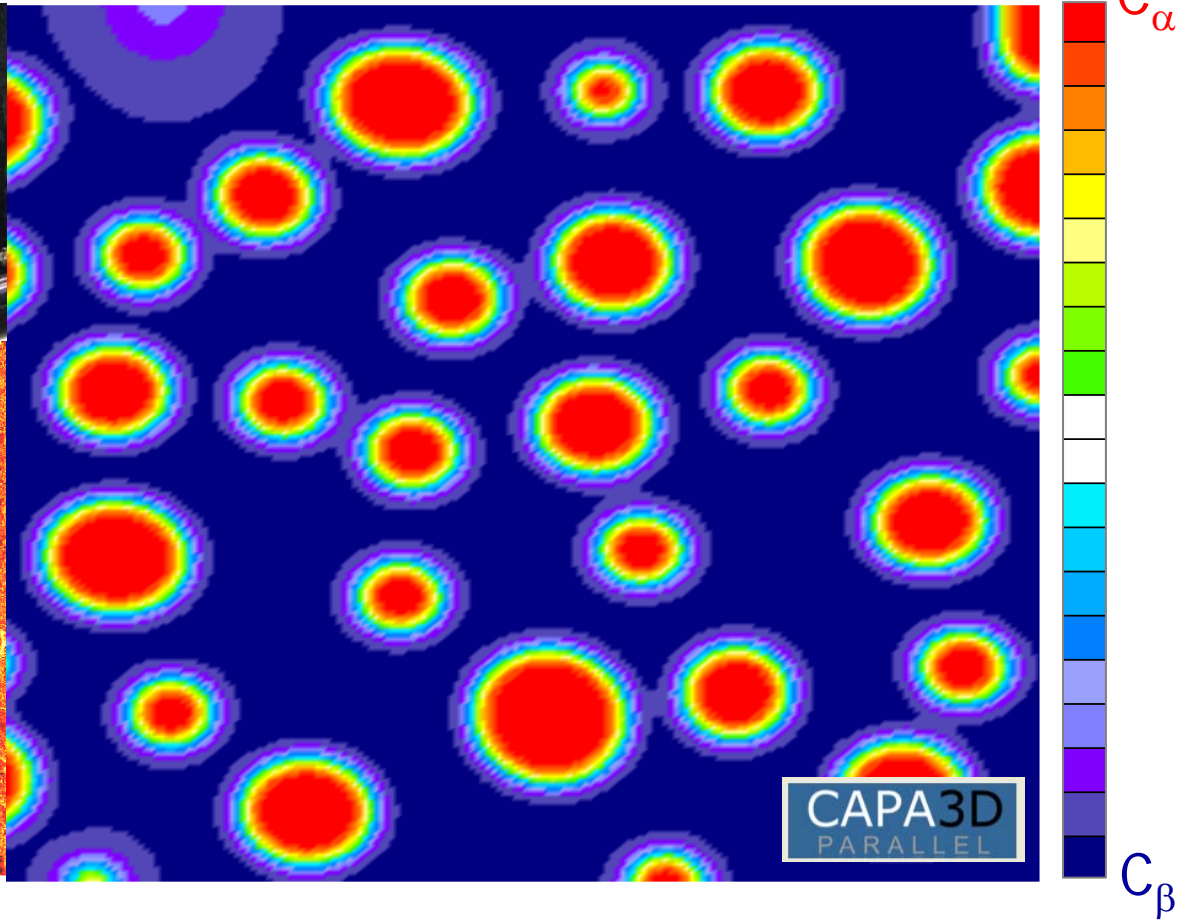
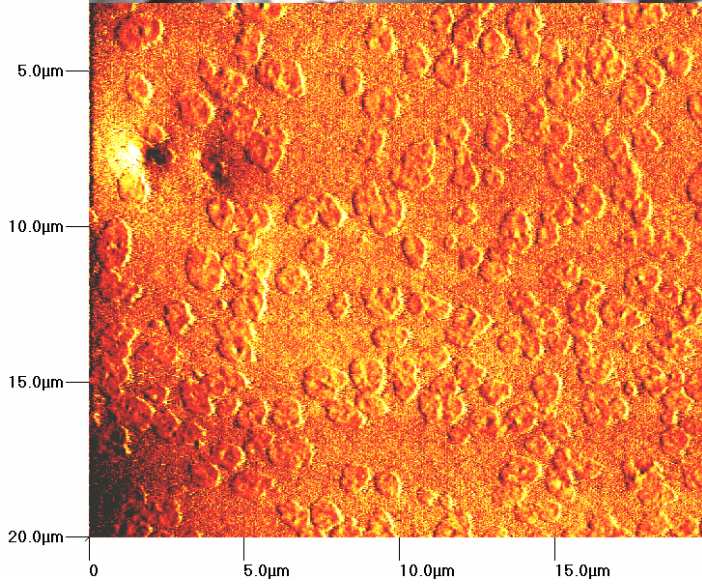
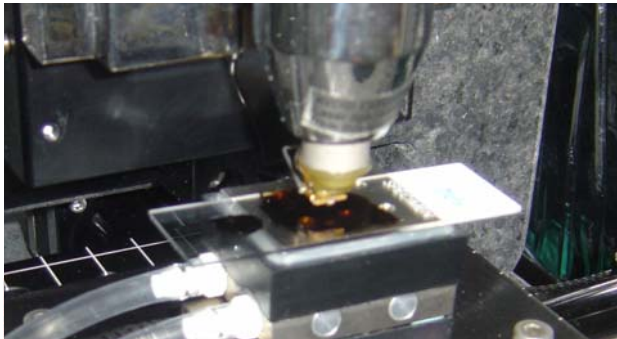
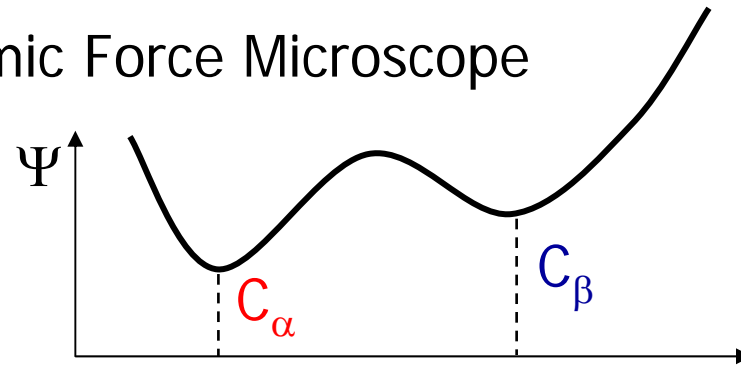
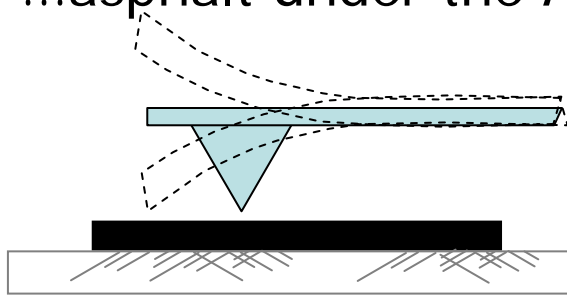

...asphalt under the Atomic Force Microscope

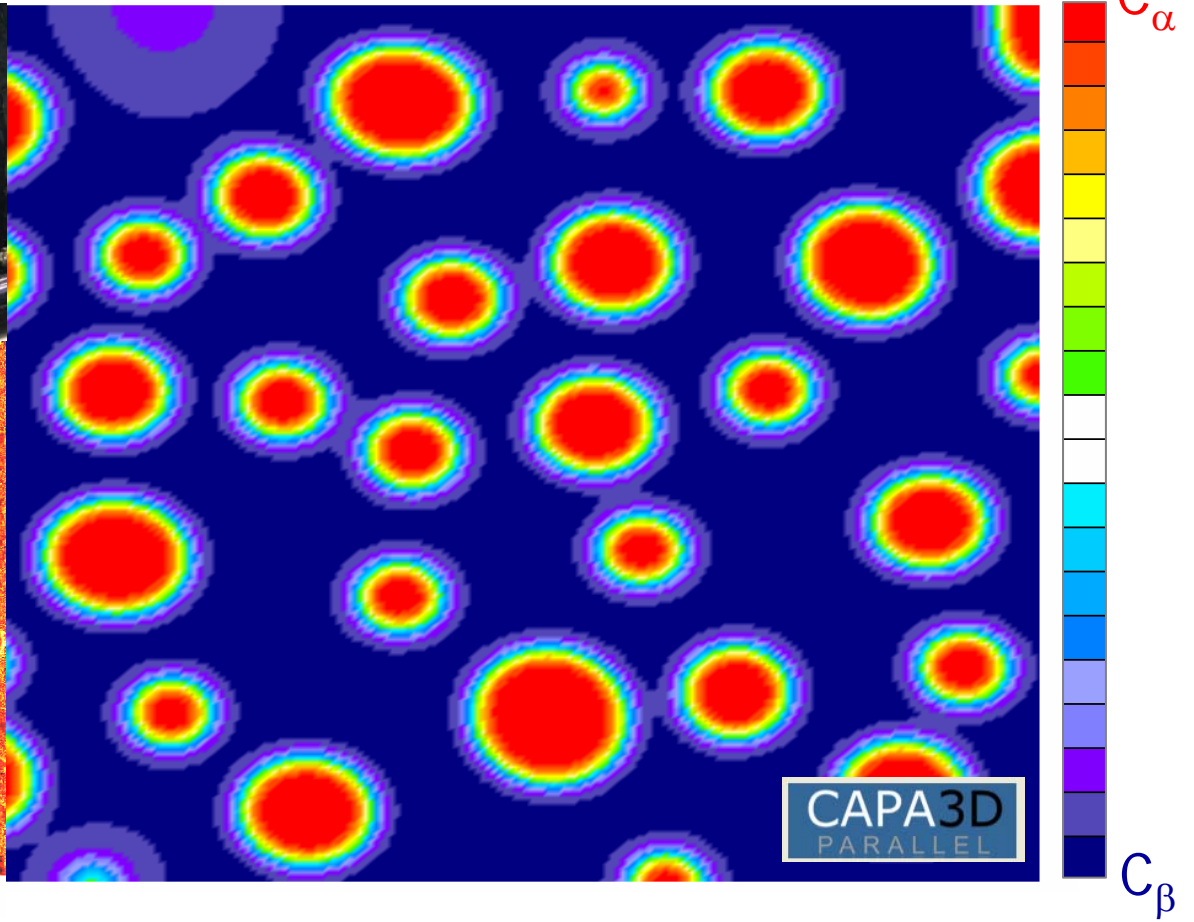
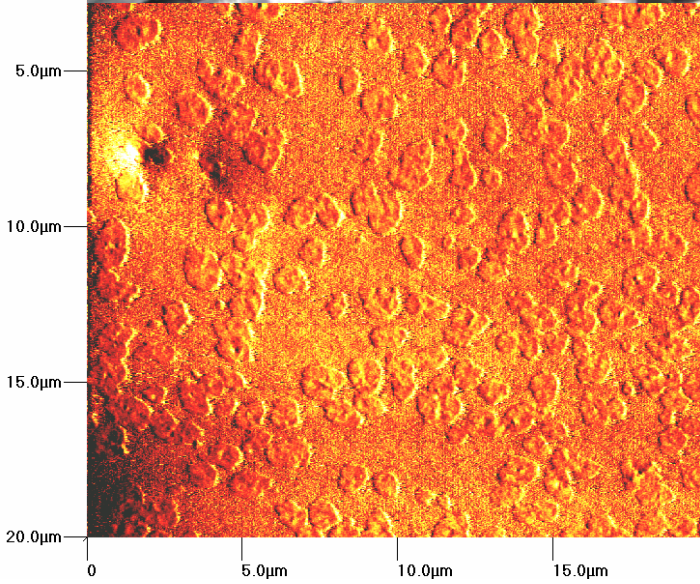
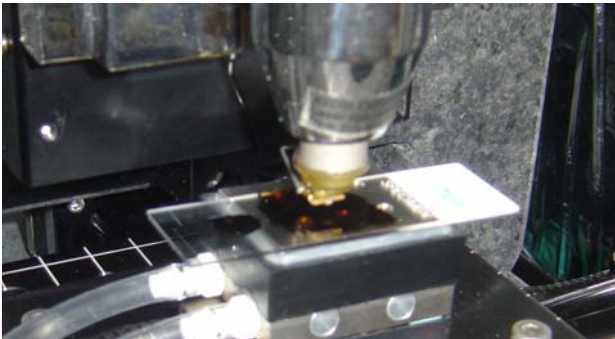
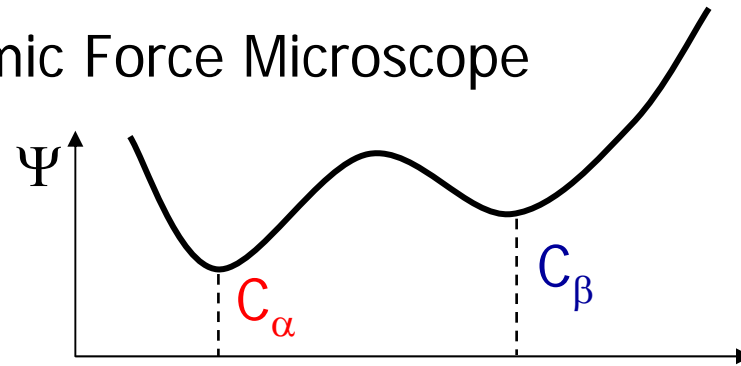
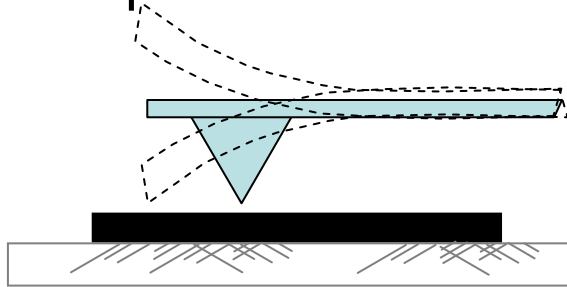

...asphalt under the Atomic Force Microscope

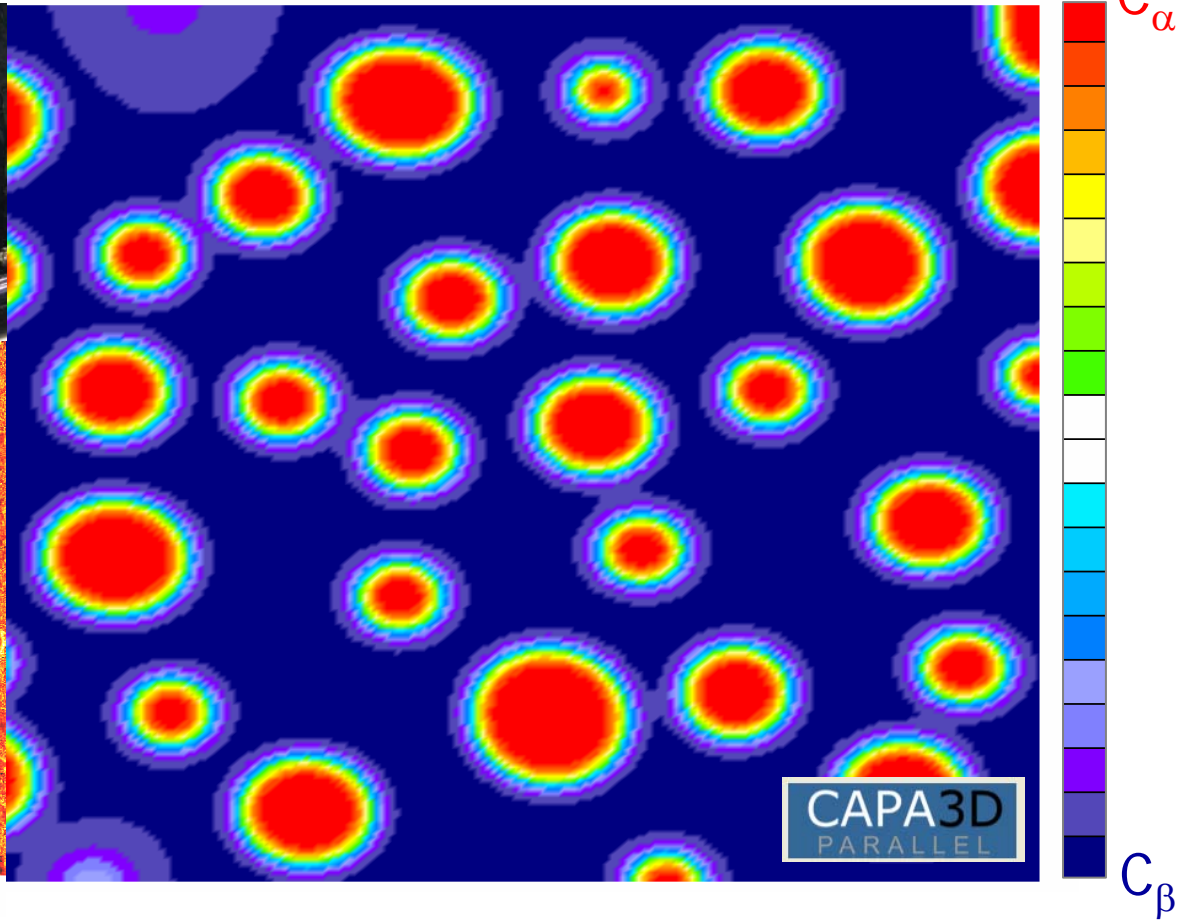
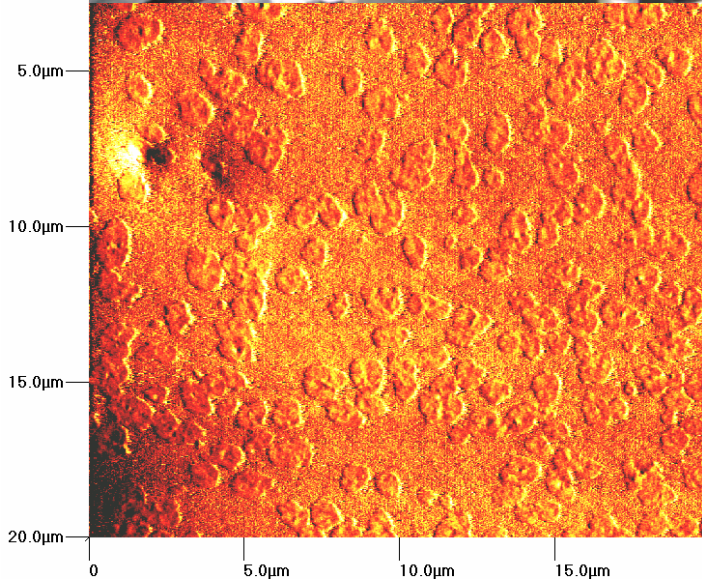
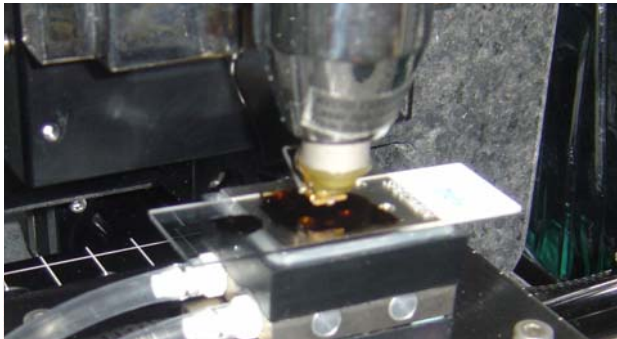
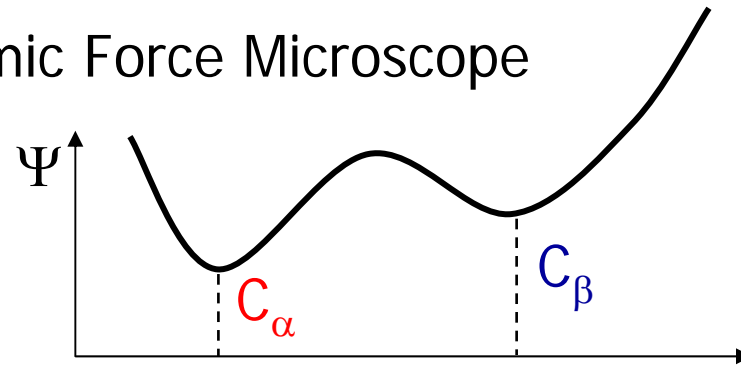
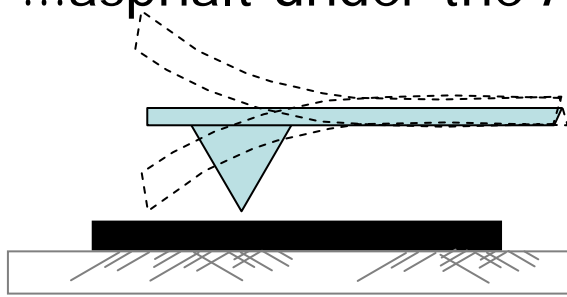

...asphalt under the Atomic Force Microscope

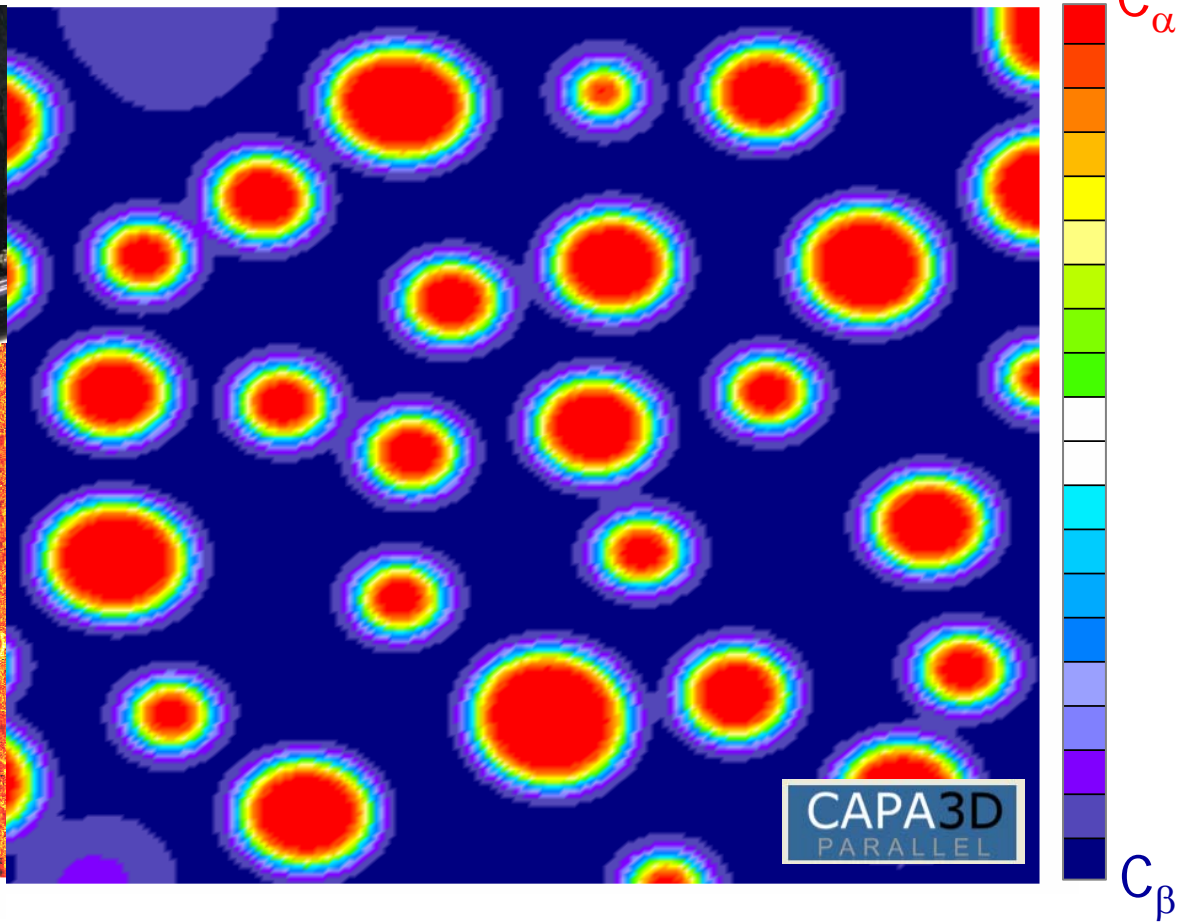
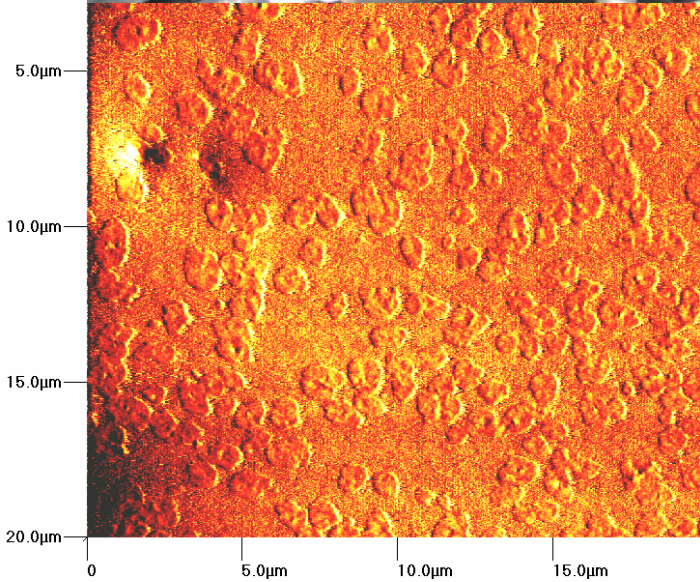
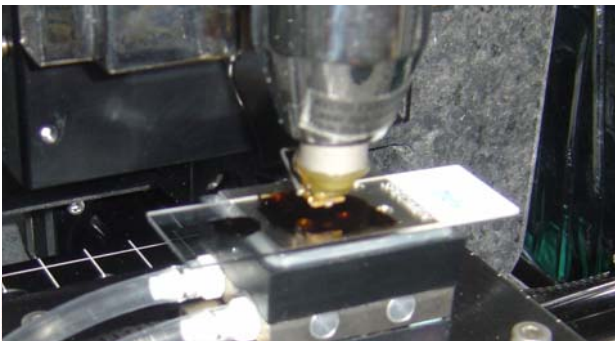
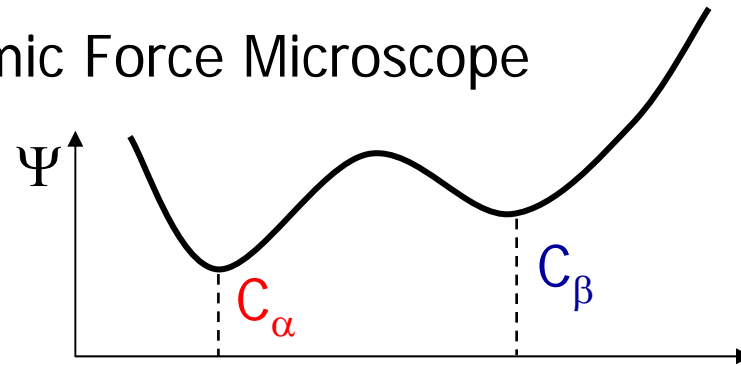
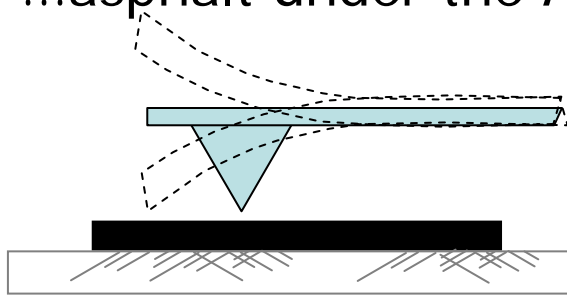

...asphalt under the Atomic Force Microscope

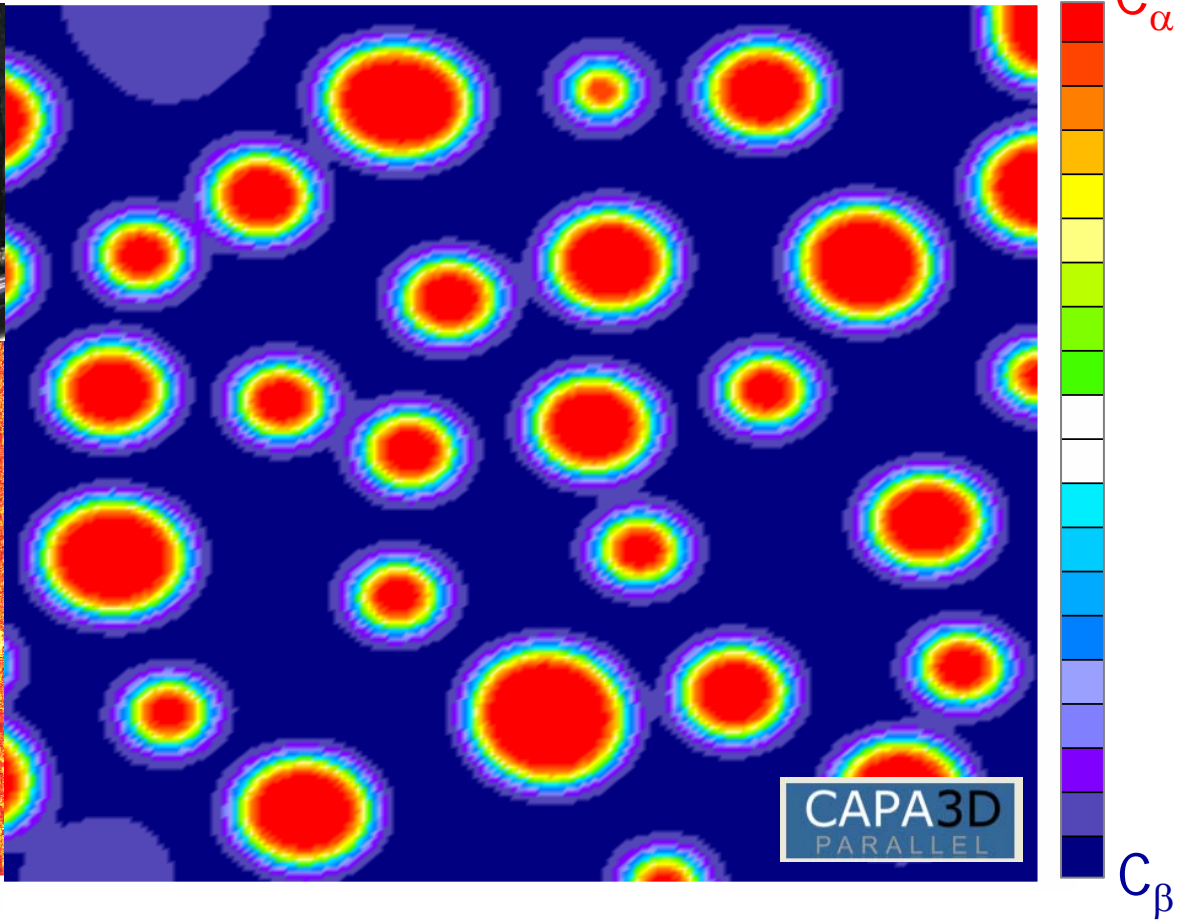
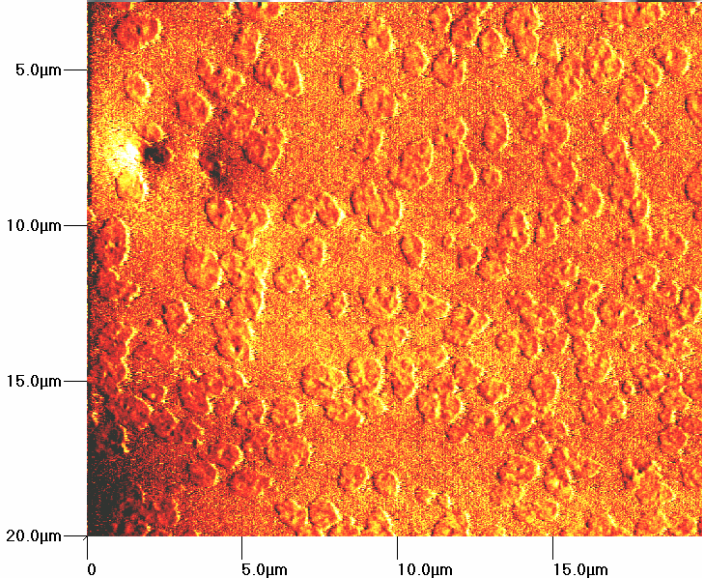
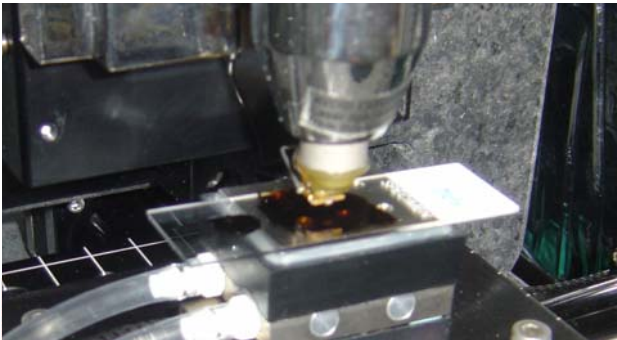
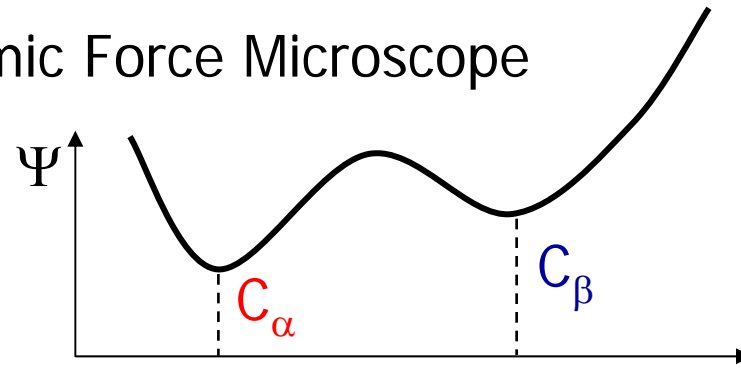
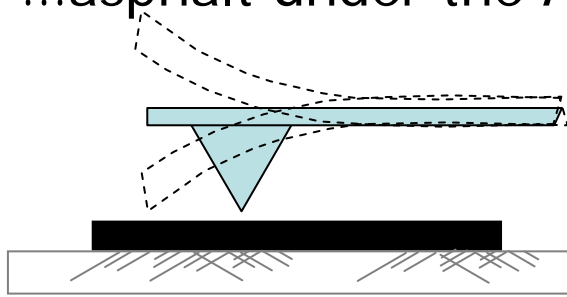

...asphalt under the Atomic Force Microscope

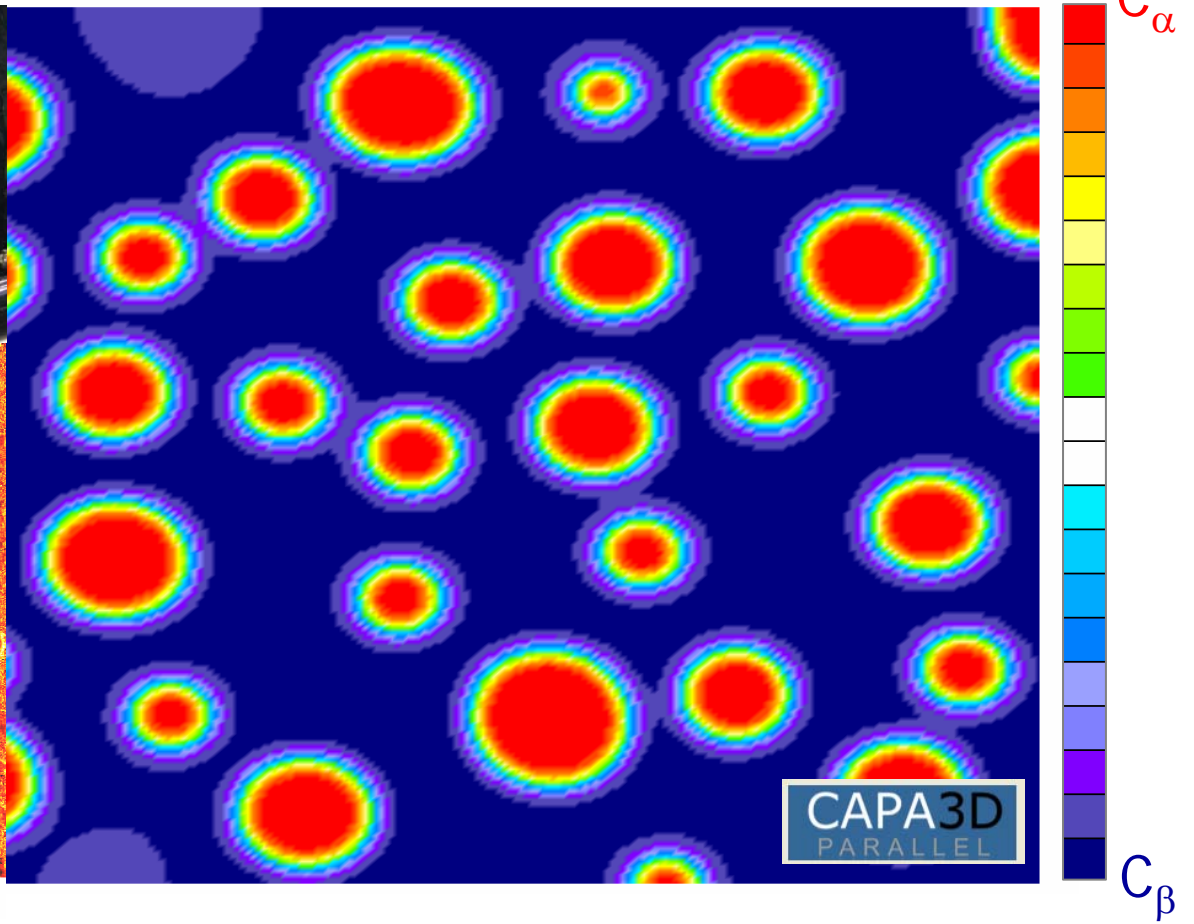
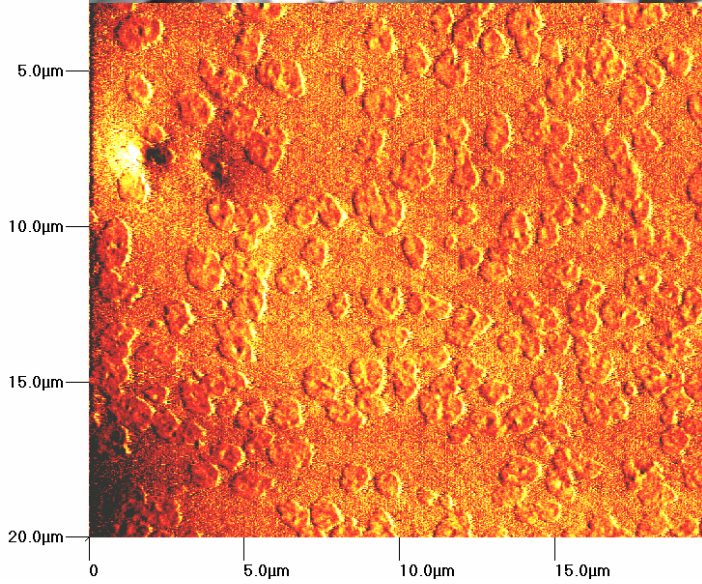
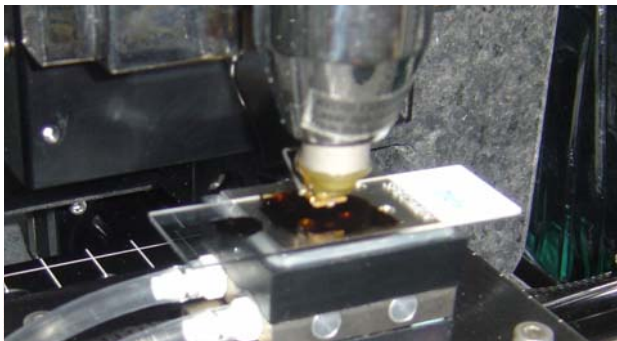
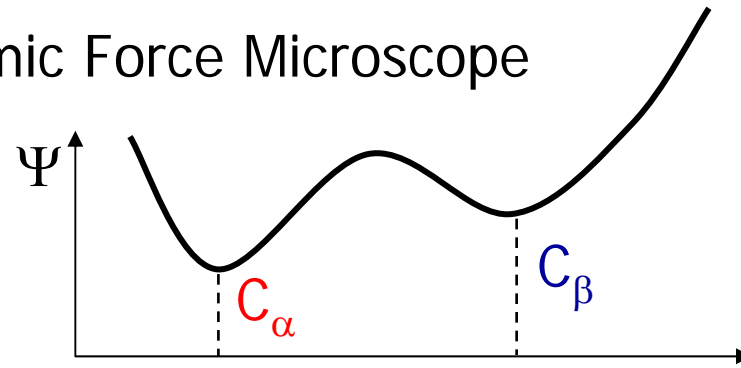
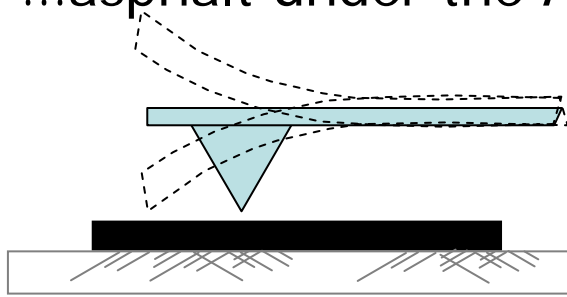

...asphalt under the Atomic Force Microscope

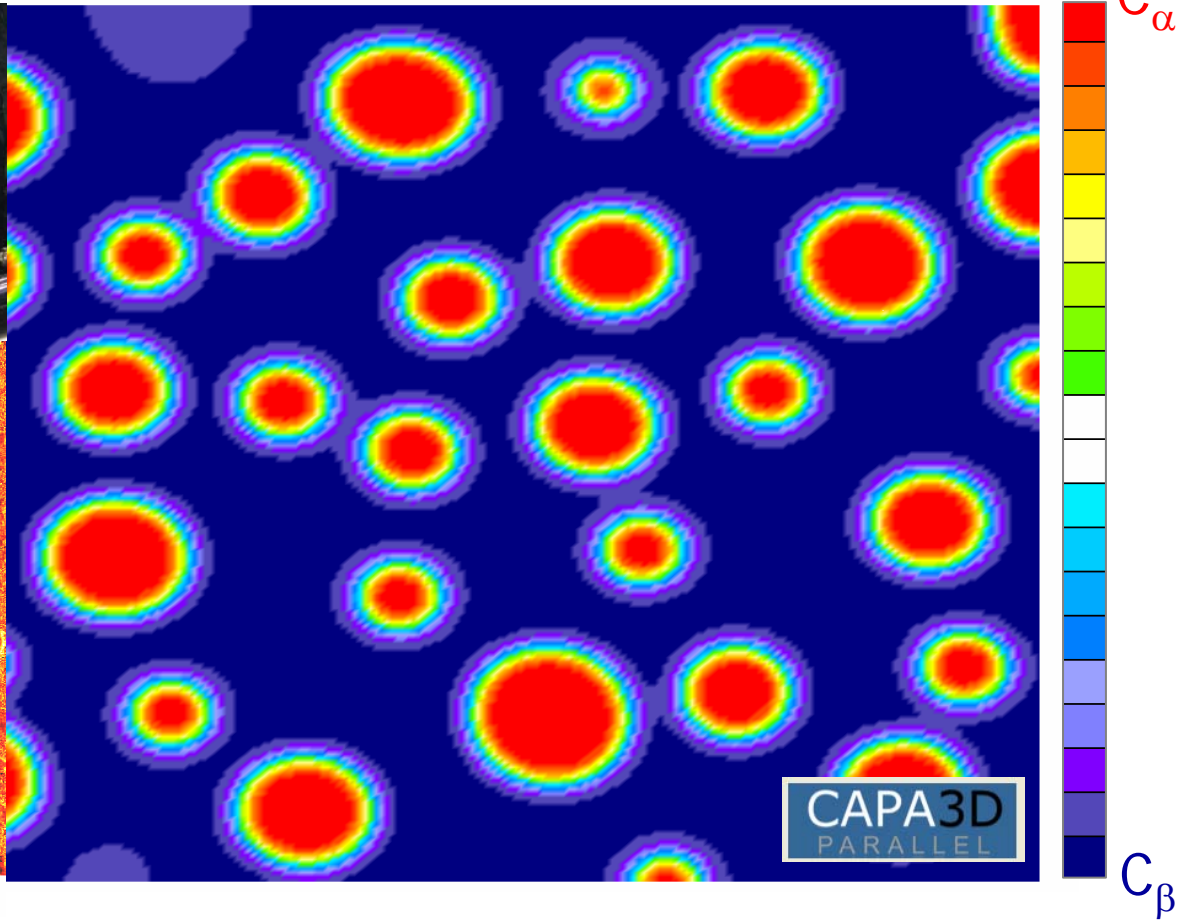
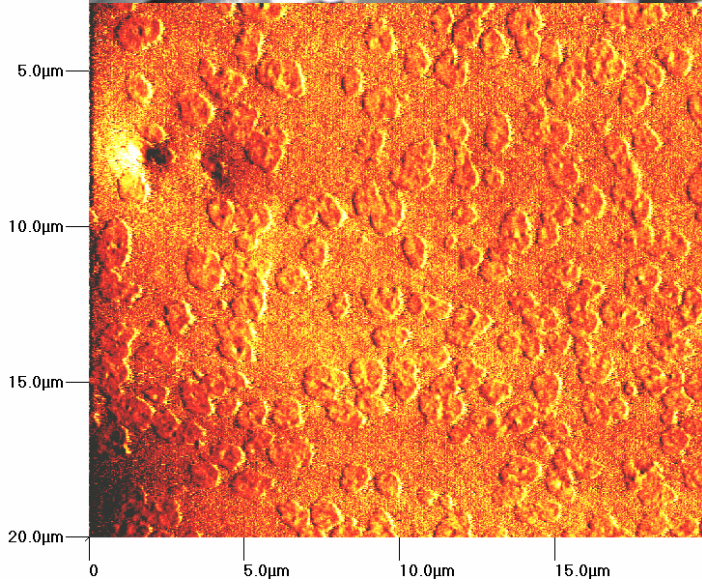
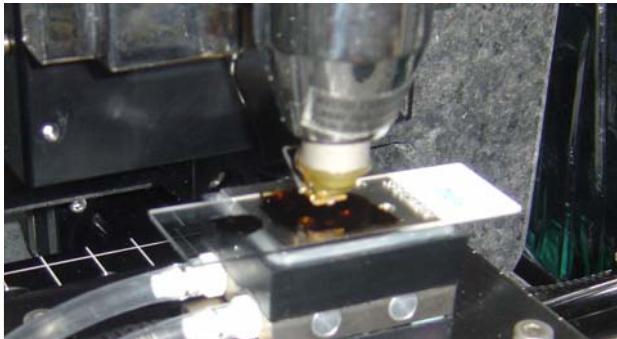
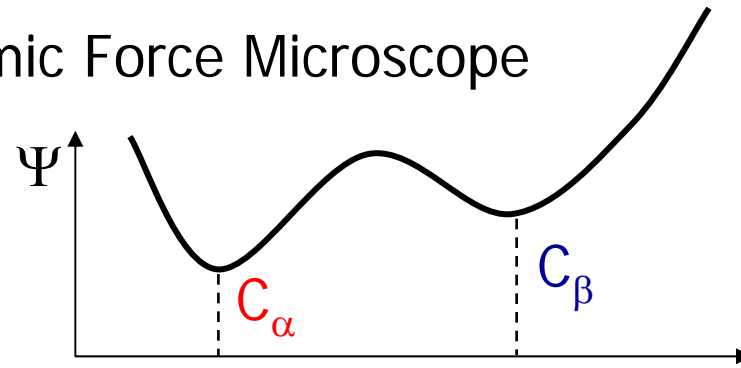
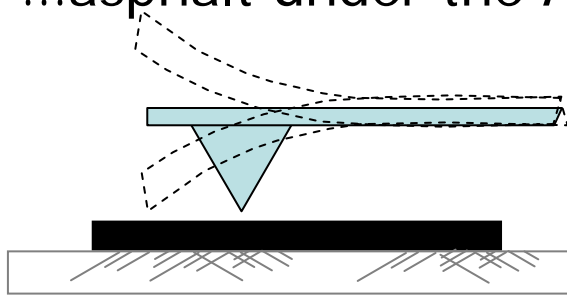

...asphalt under the Atomic Force Microscope

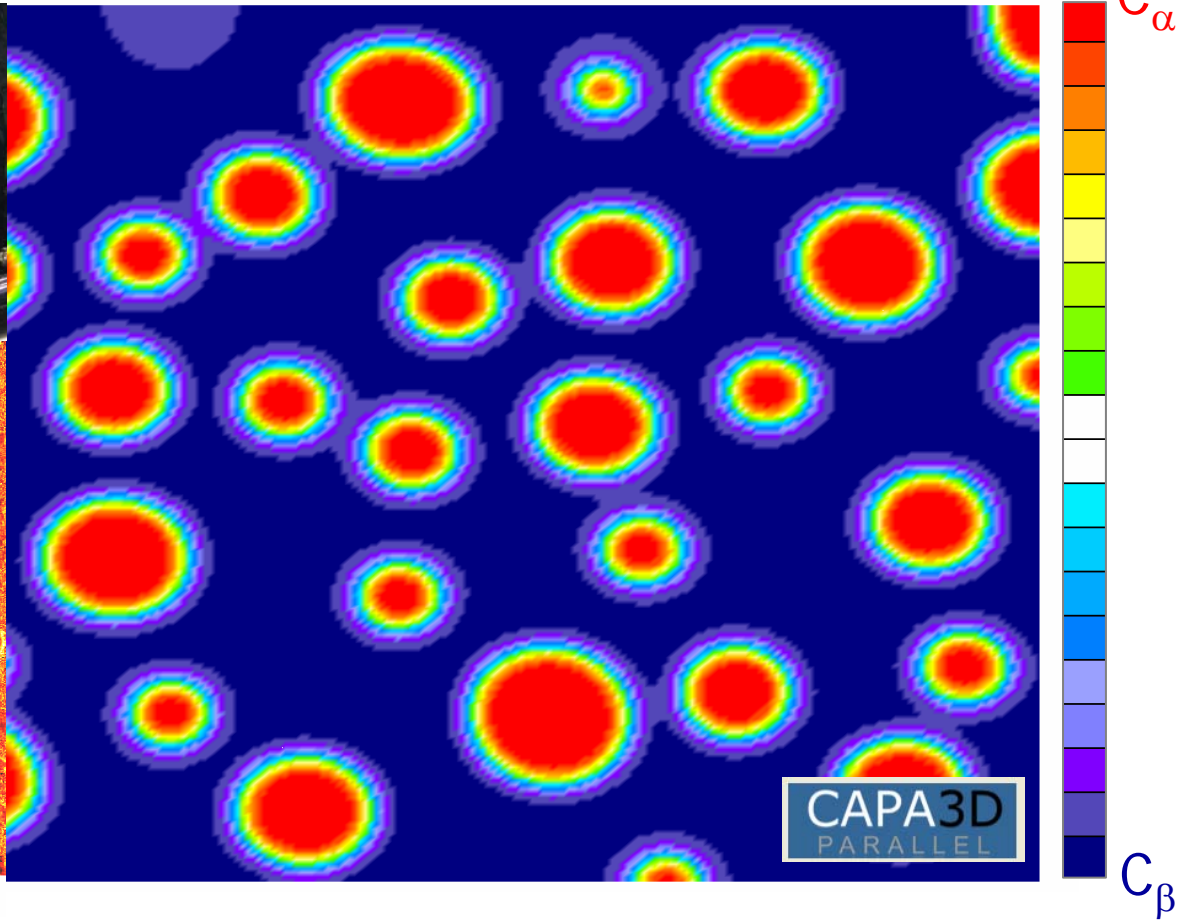
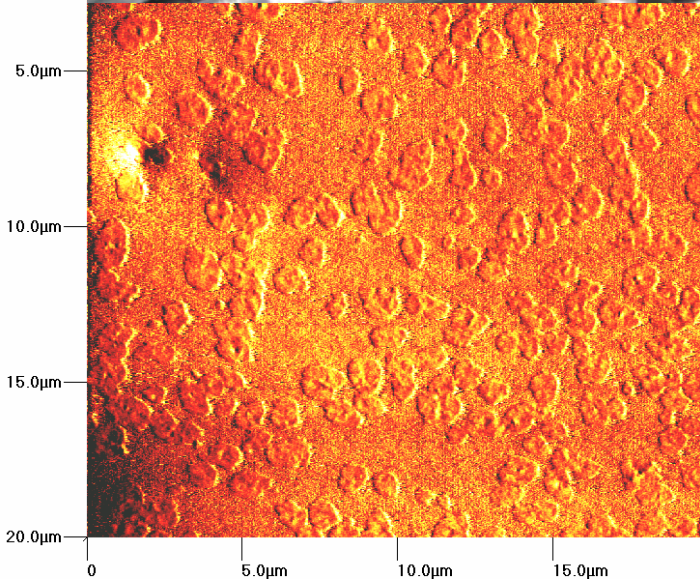
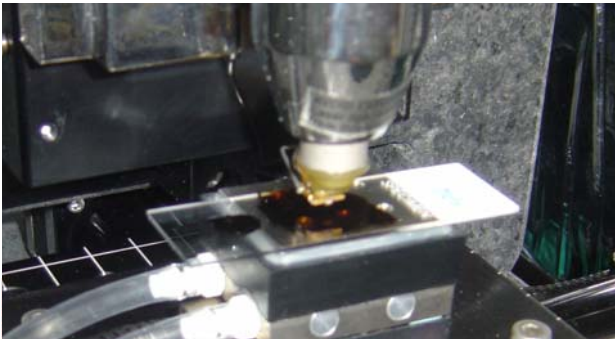
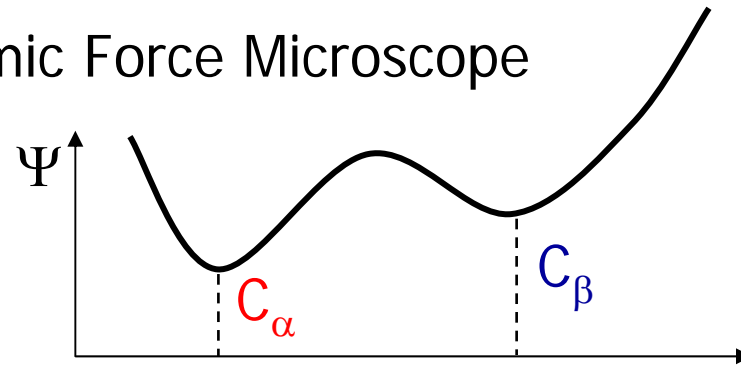
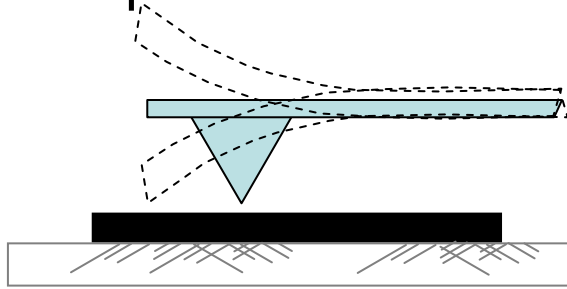

...asphalt under the Atomic Force Microscope

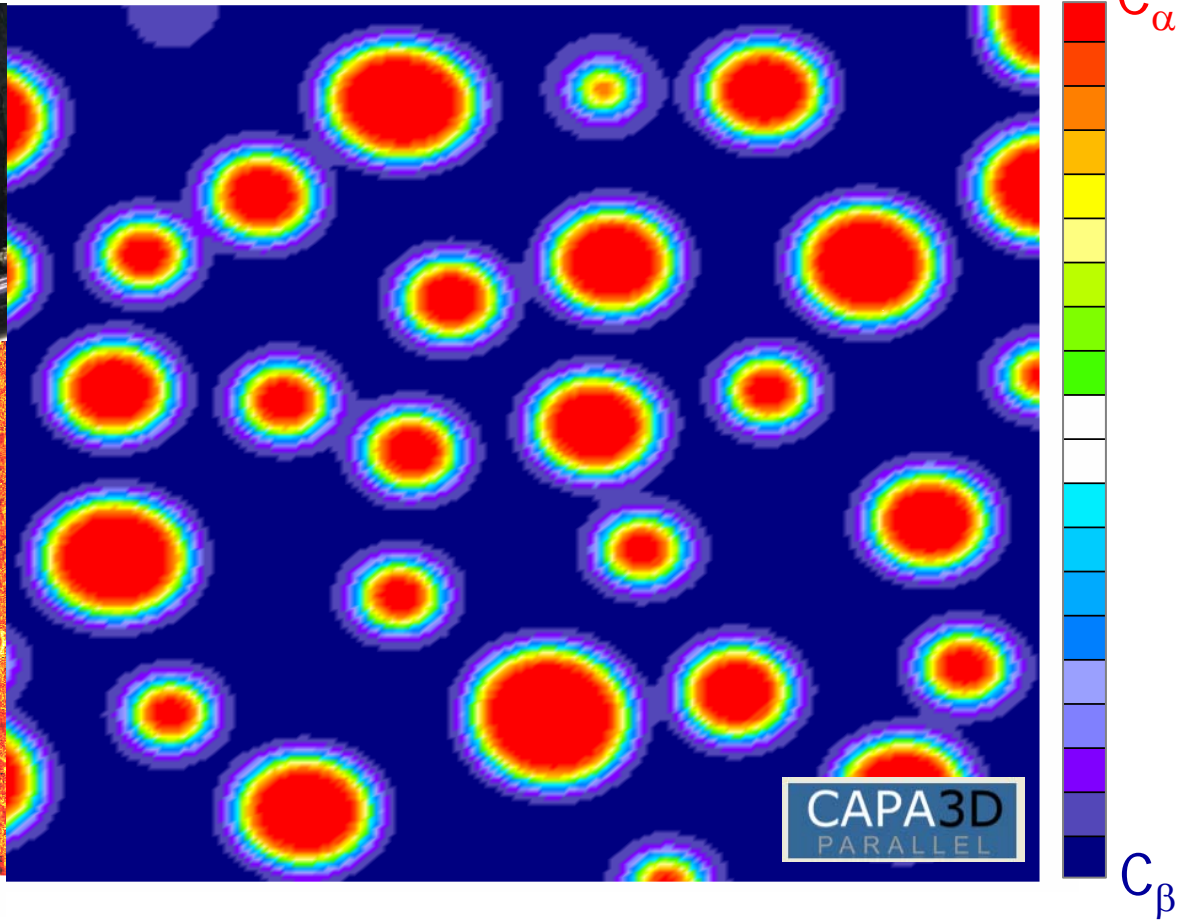
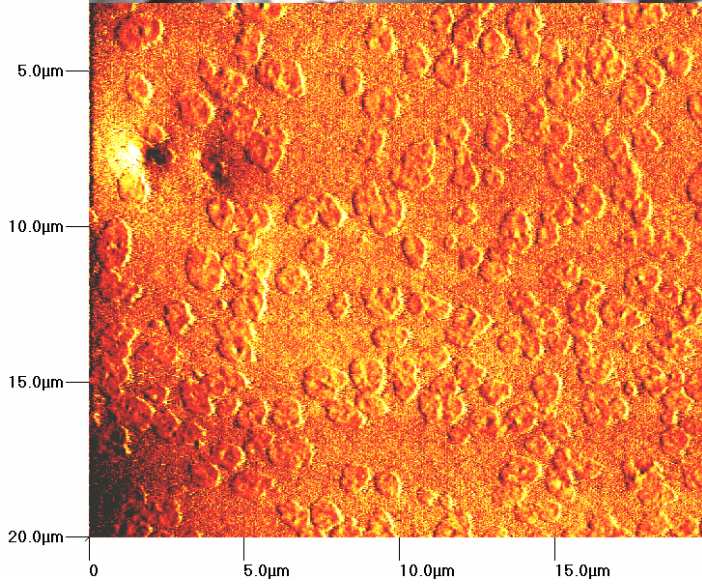
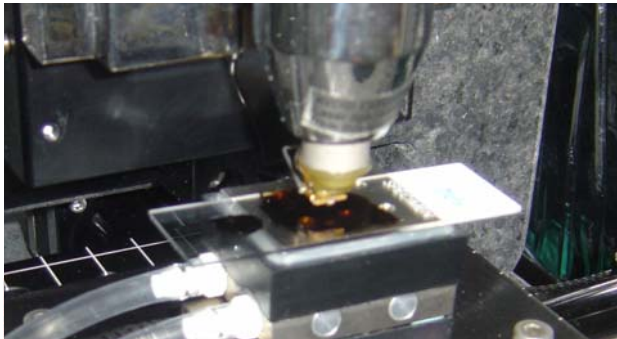
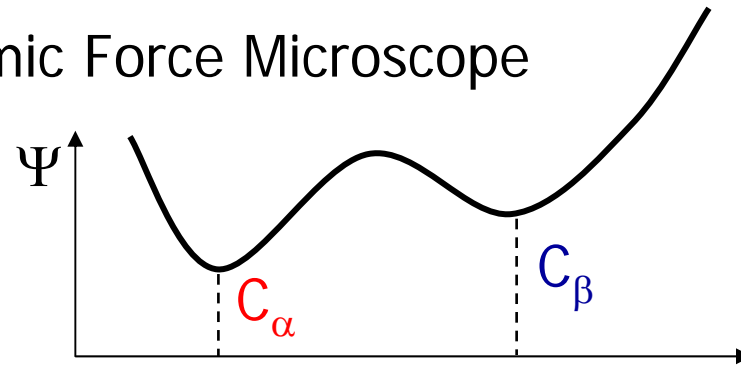
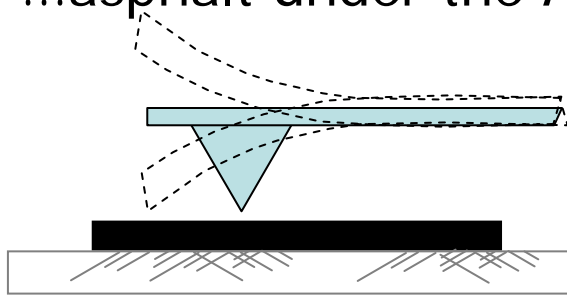

...asphalt under the Atomic Force Microscope

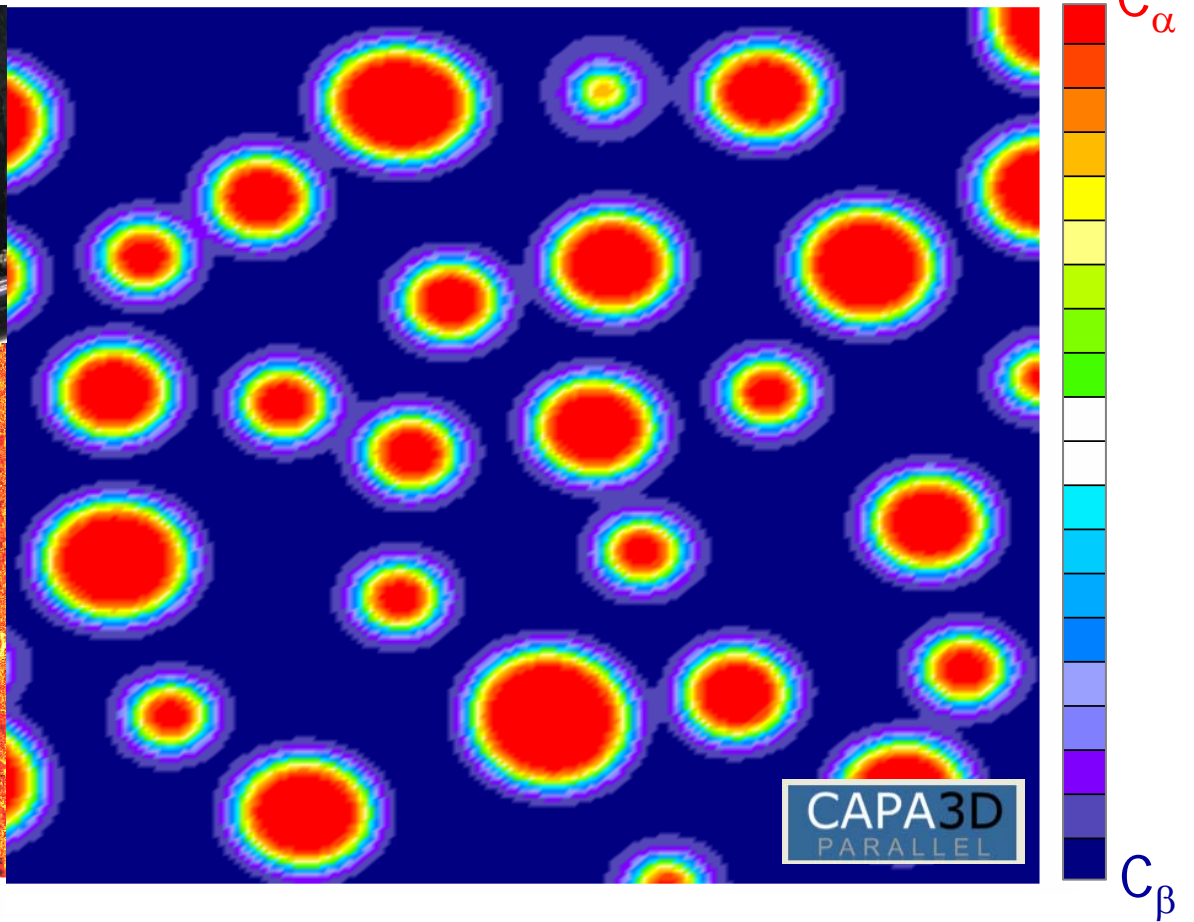
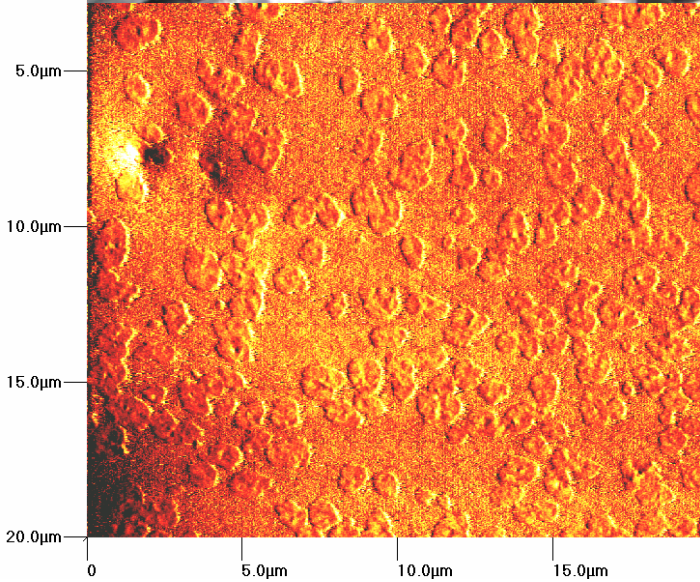
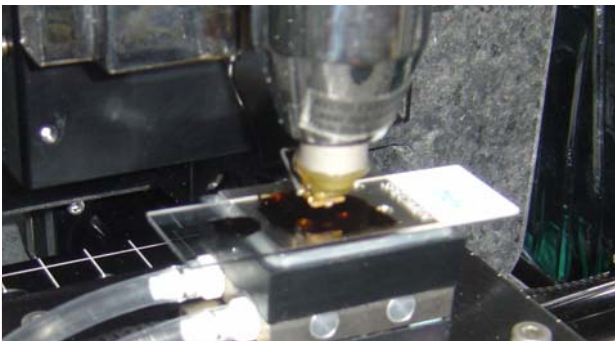
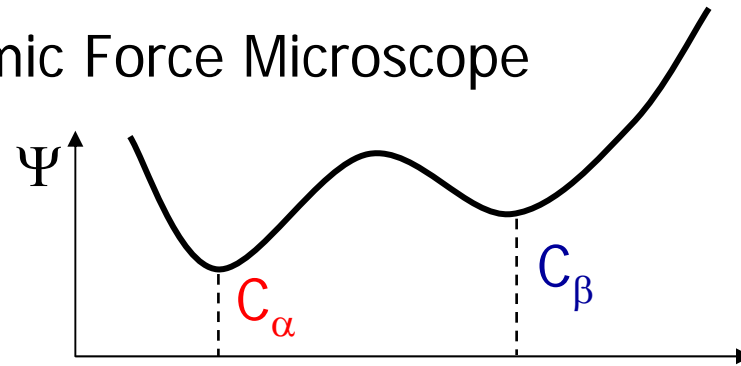
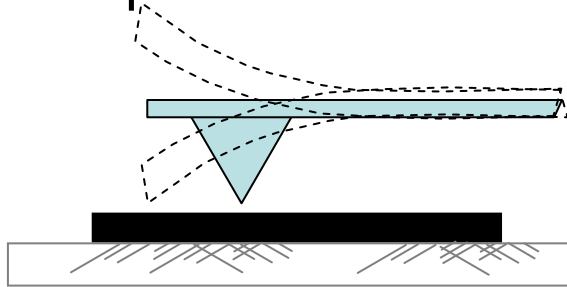

...asphalt under the Atomic Force Microscope

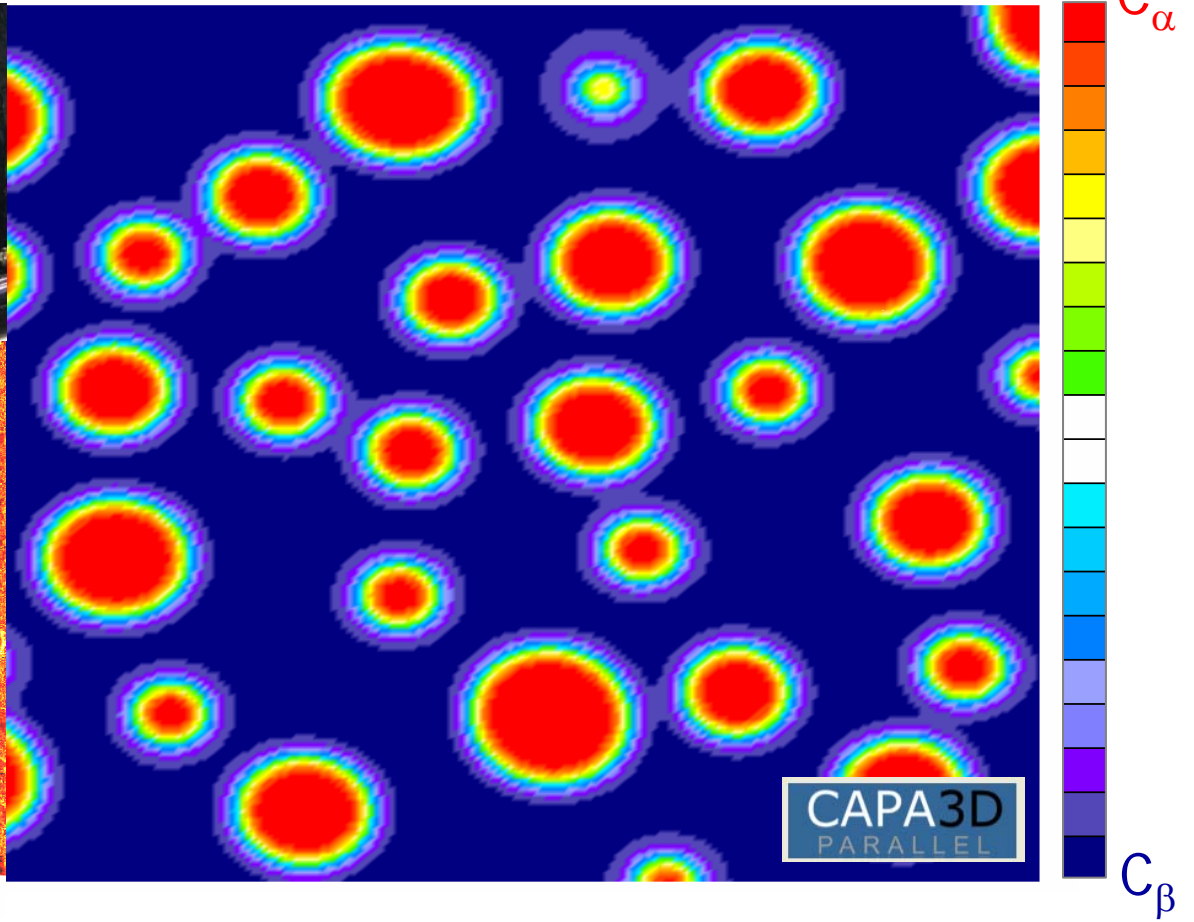
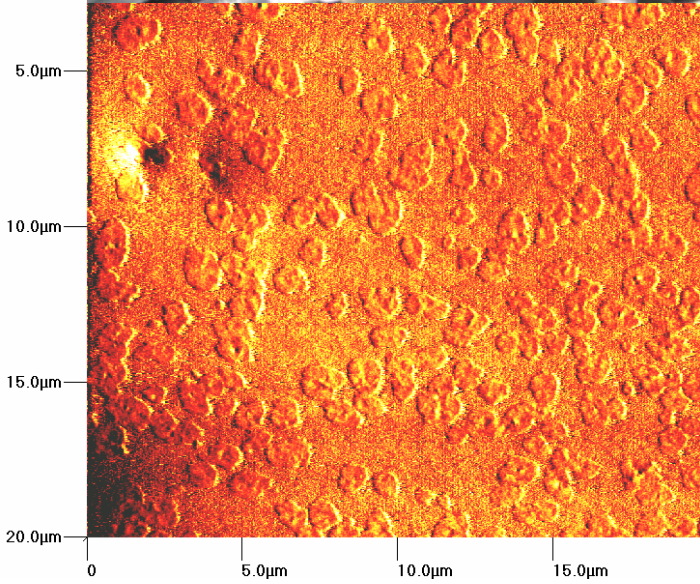
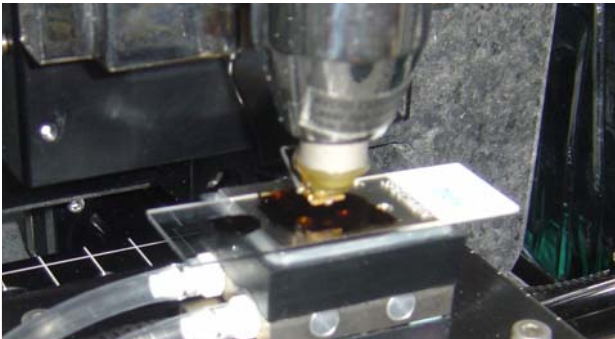
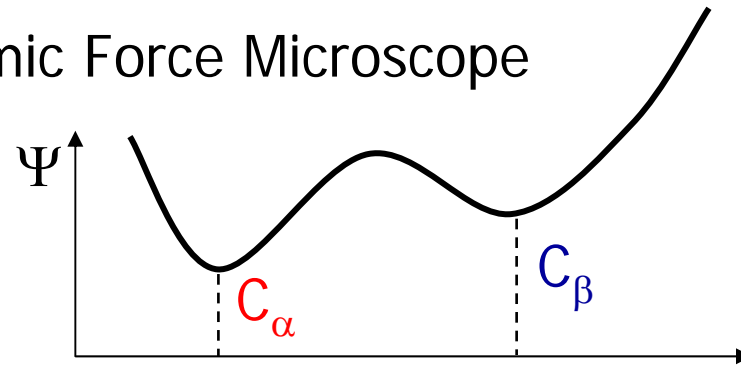
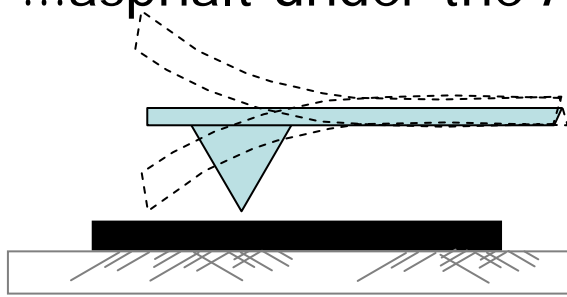

...asphalt under the Atomic Force Microscope

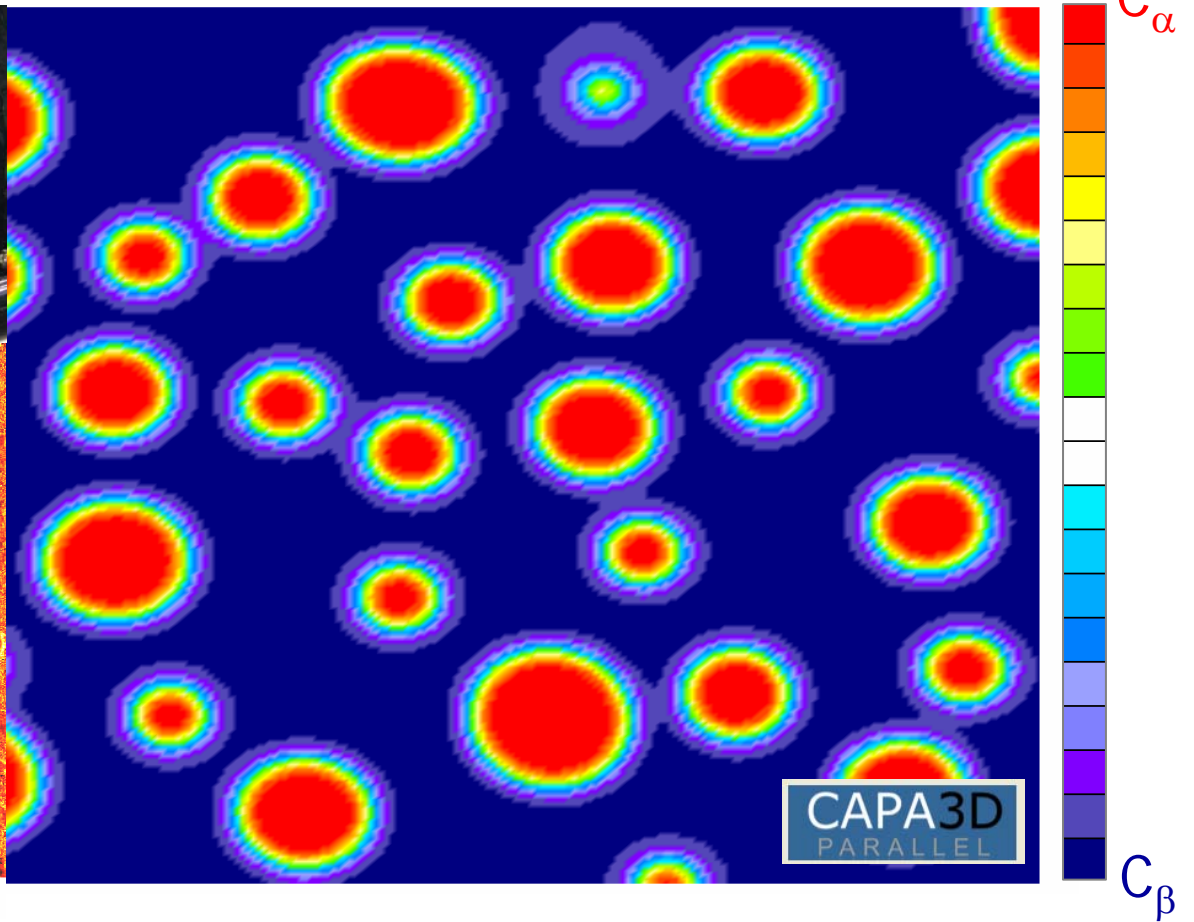
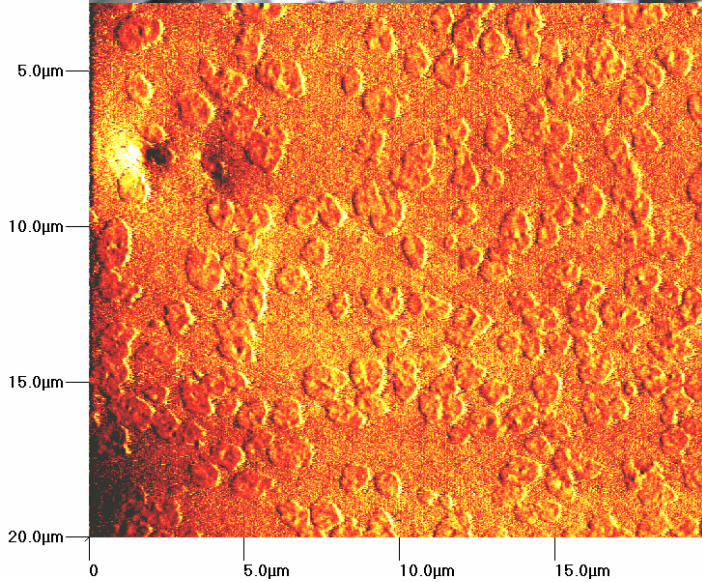
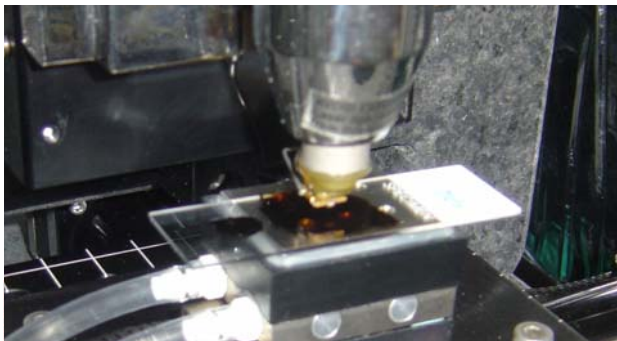
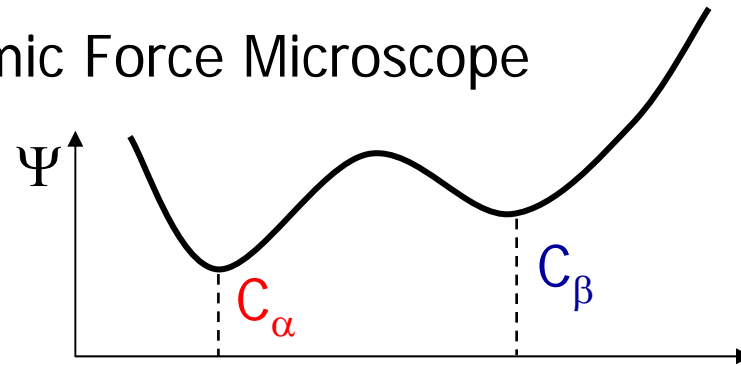
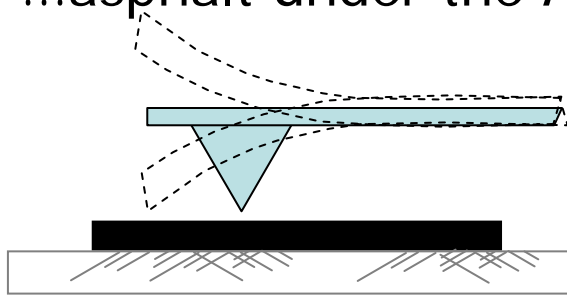

...asphalt under the Atomic Force Microscope

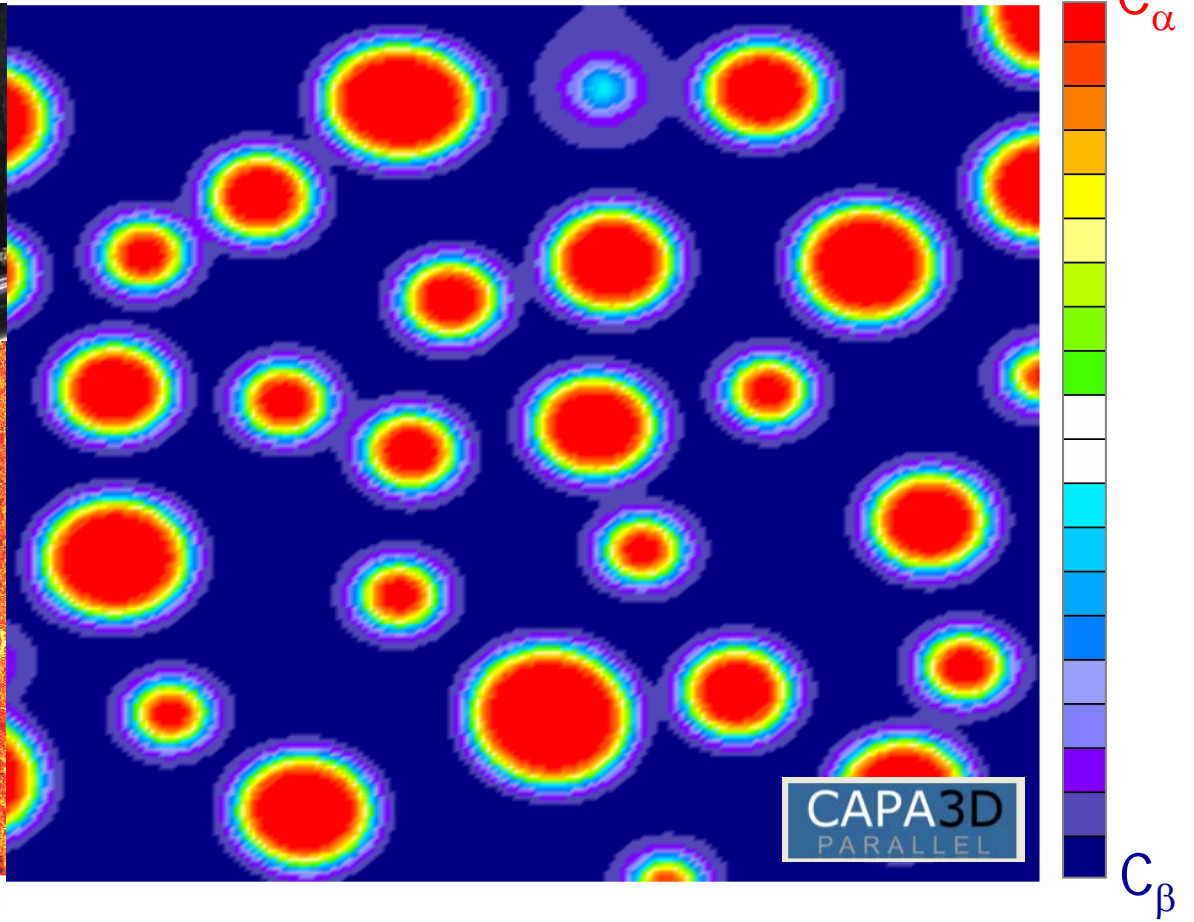
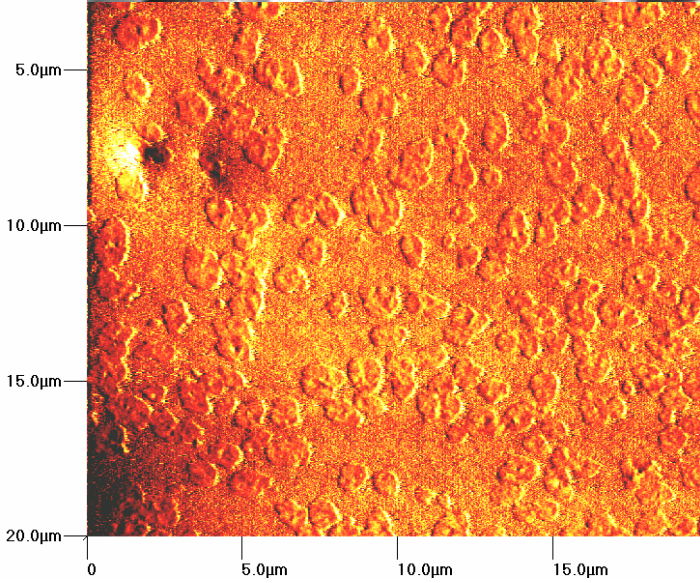
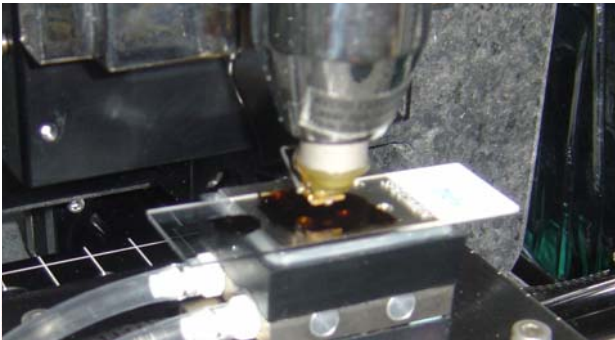
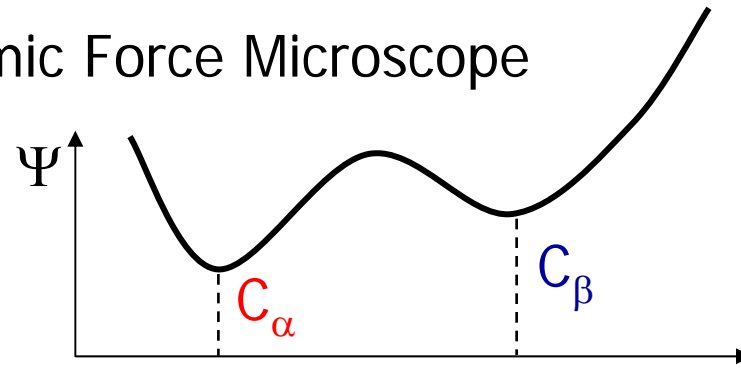
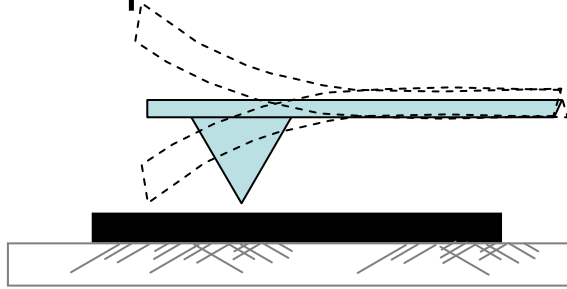

...asphalt under the Atomic Force Microscope

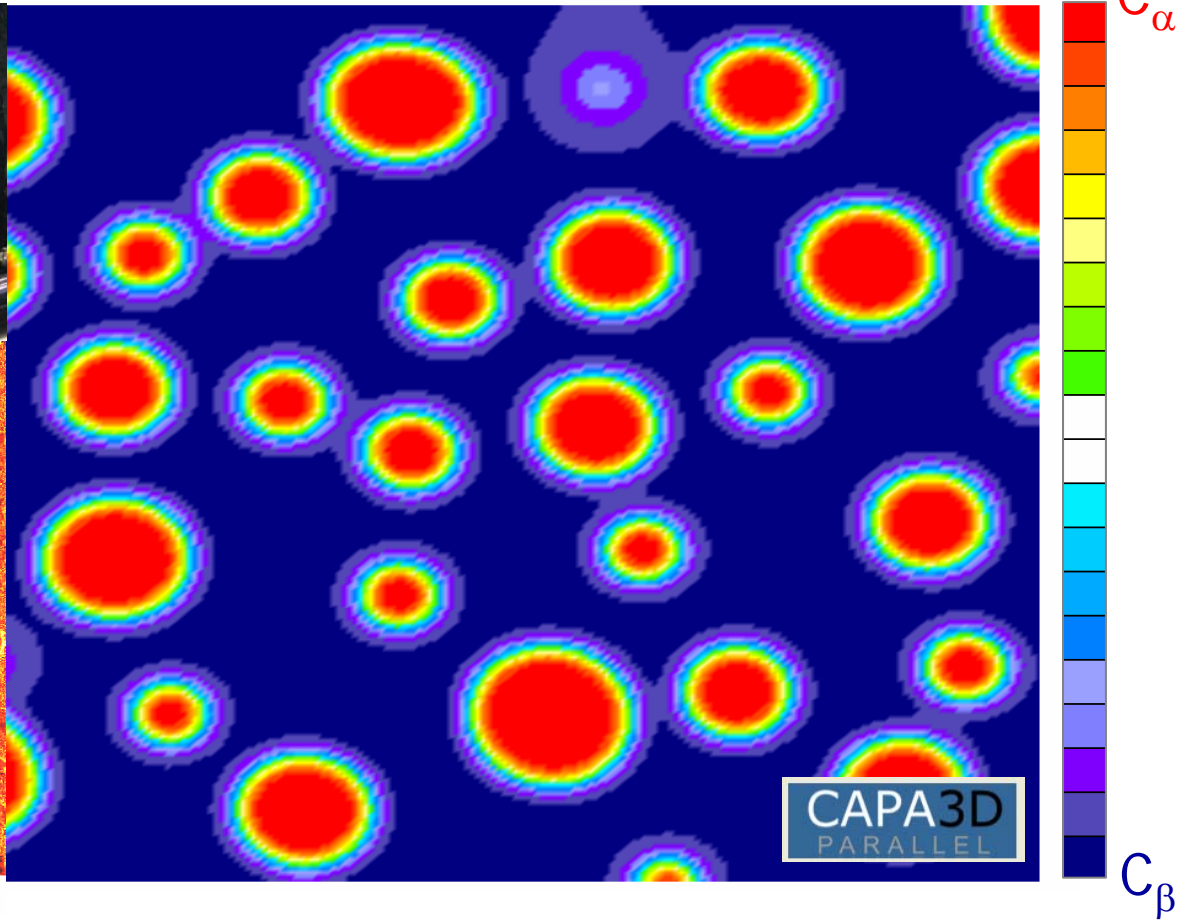
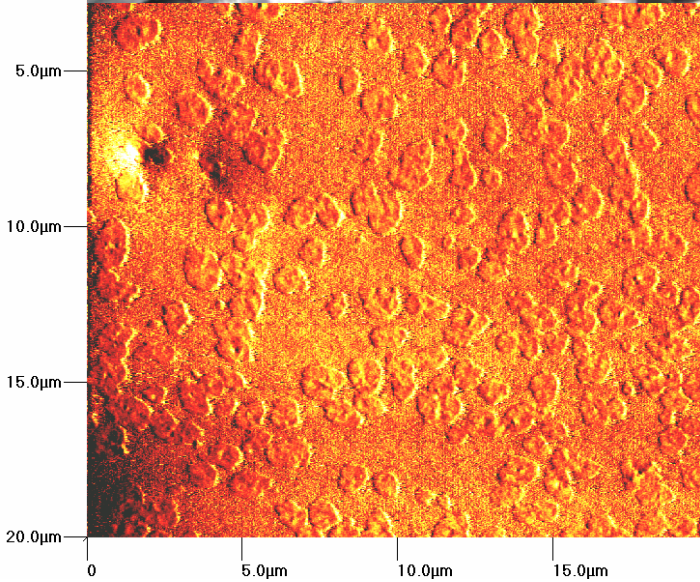
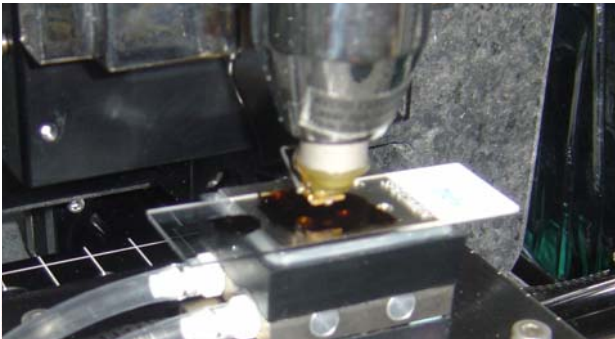
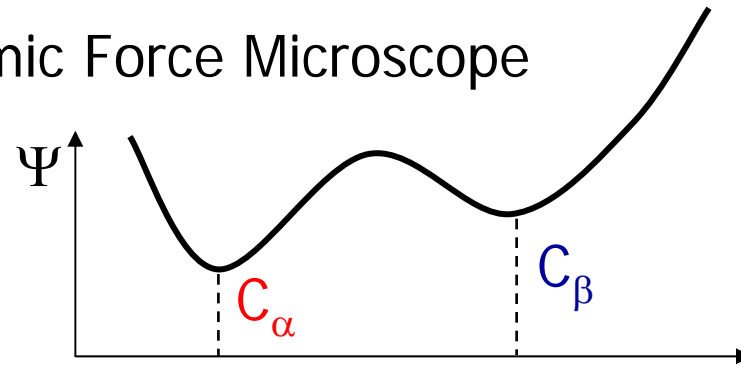
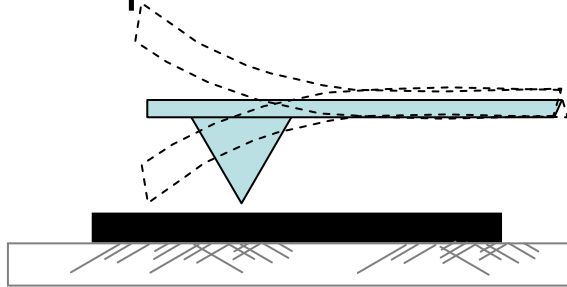

...asphalt under the Atomic Force Microscope

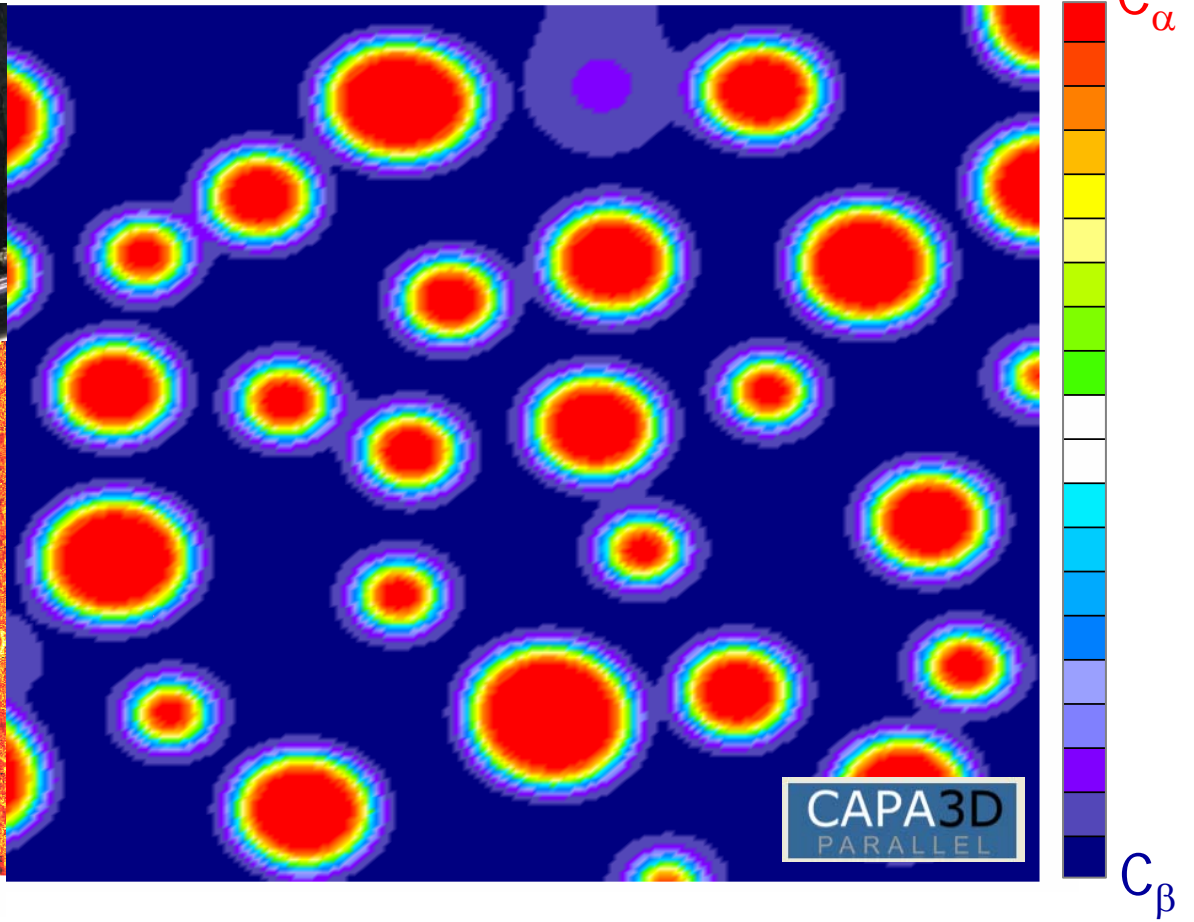
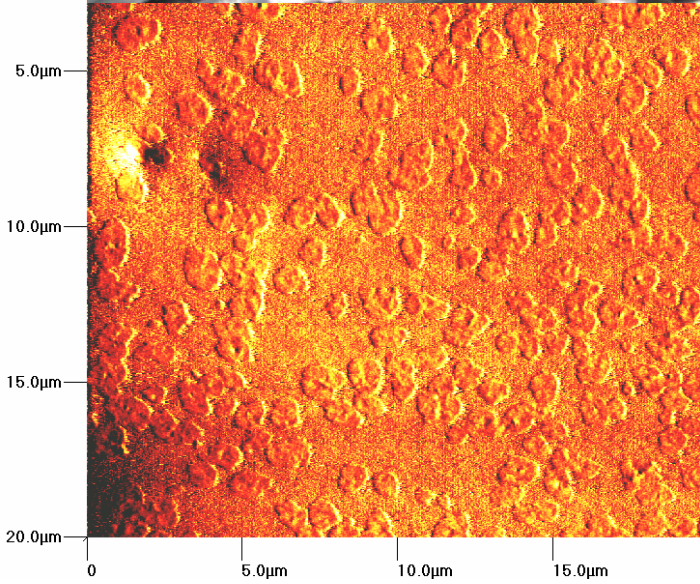
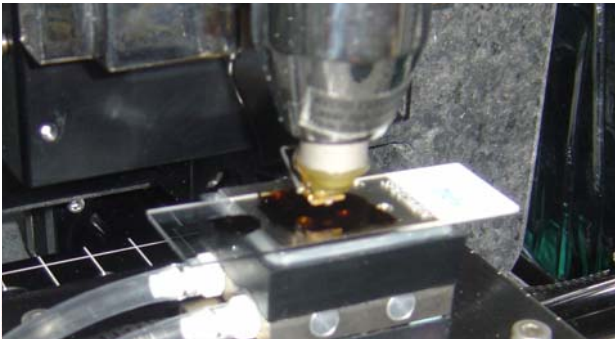
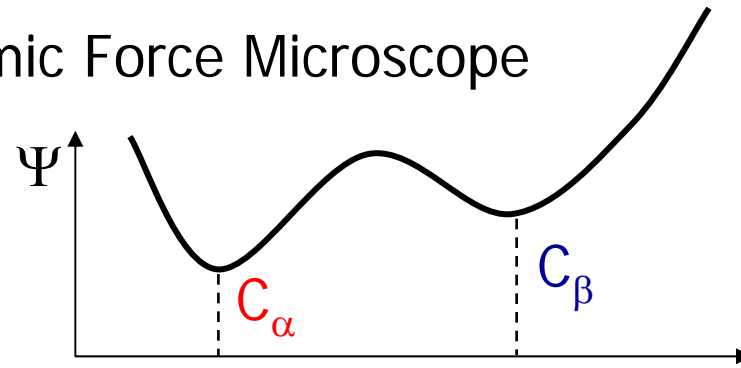
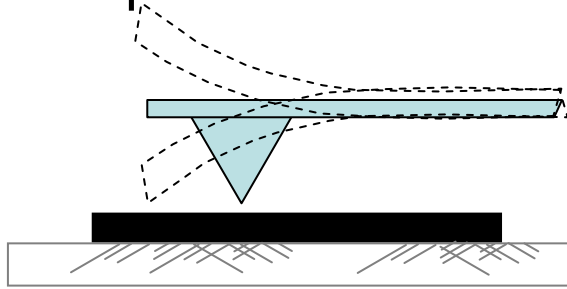

...asphalt under the Atomic Force Microscope

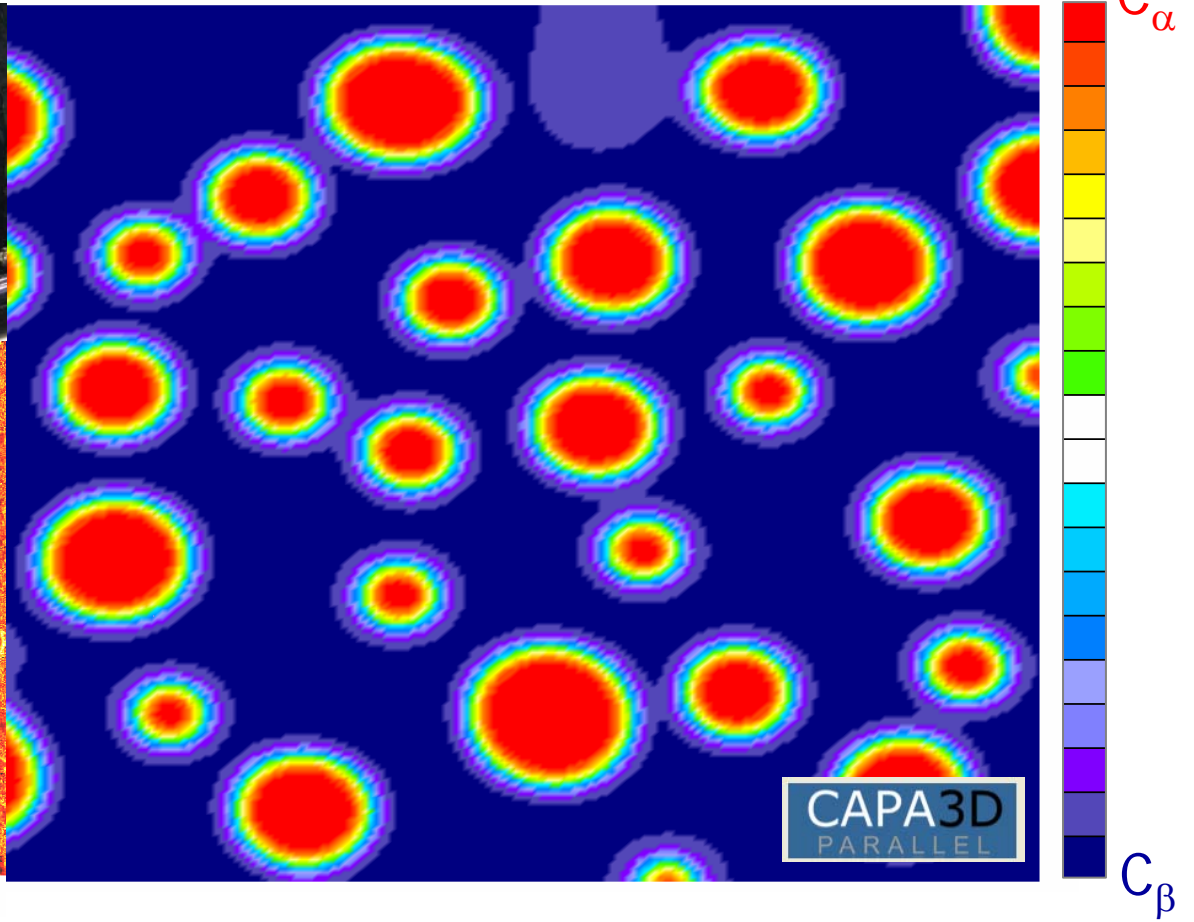
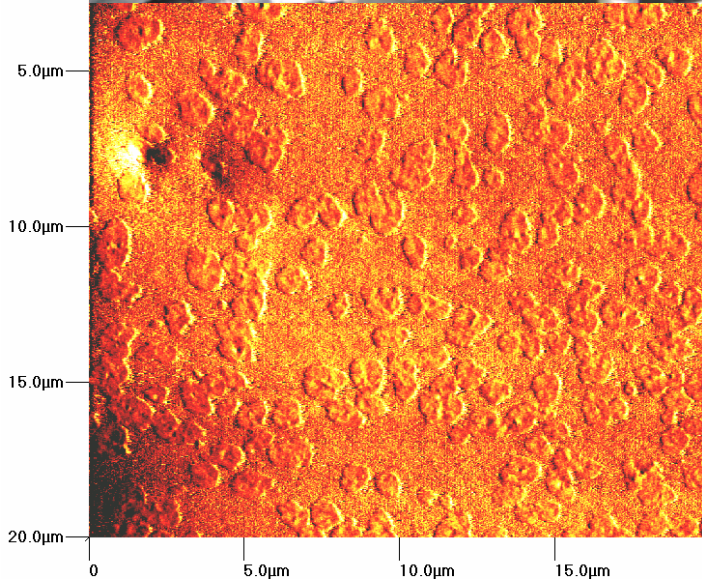
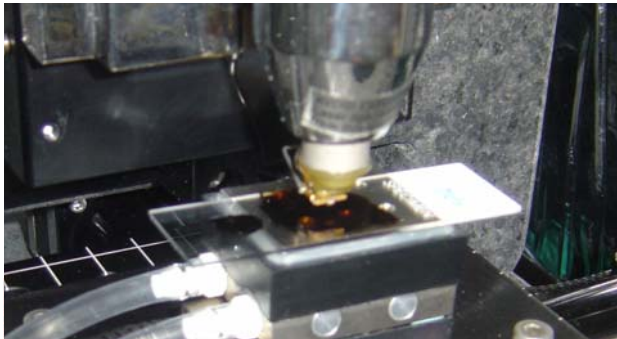
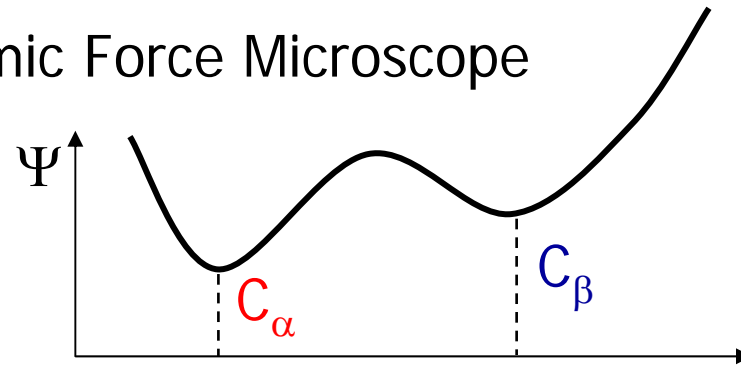
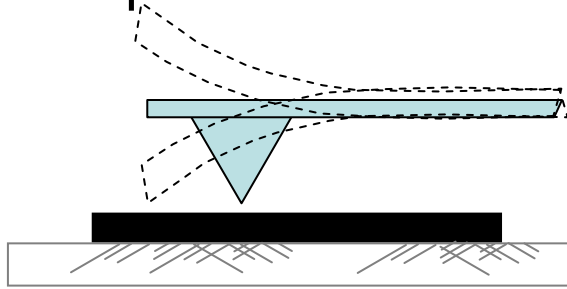

...asphalt under the Atomic Force Microscope

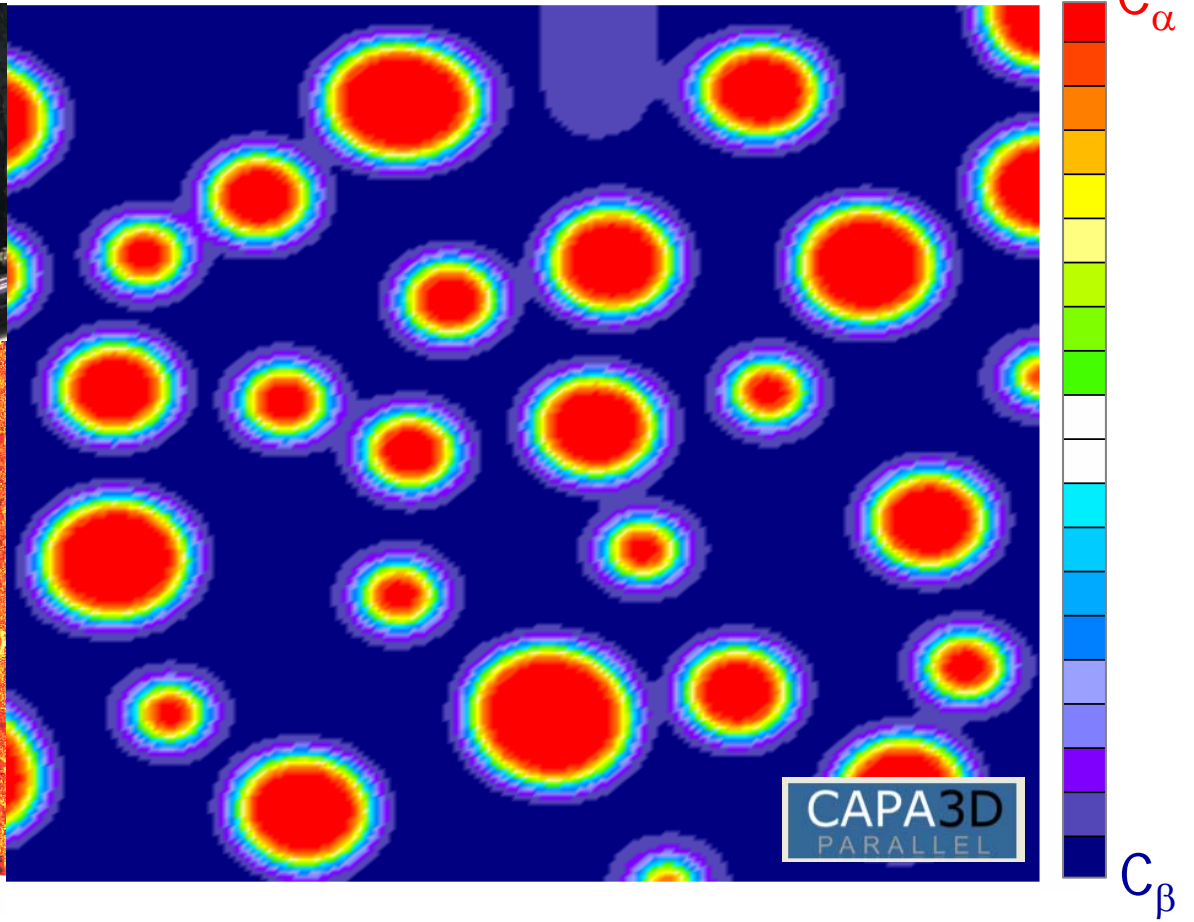
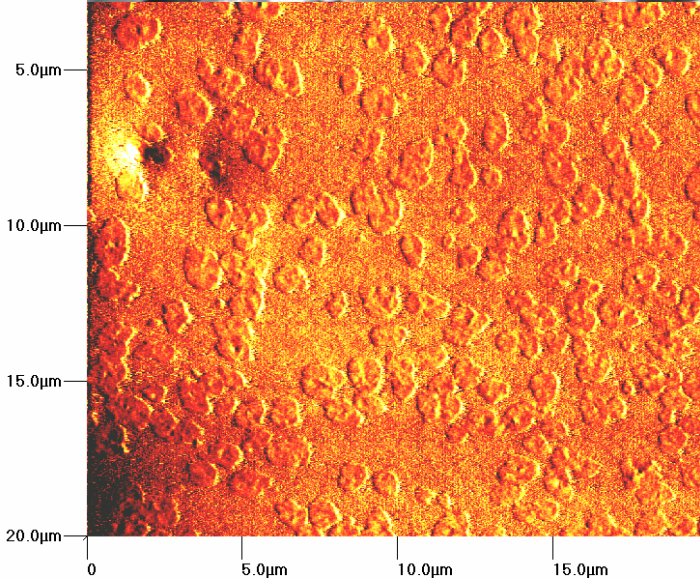
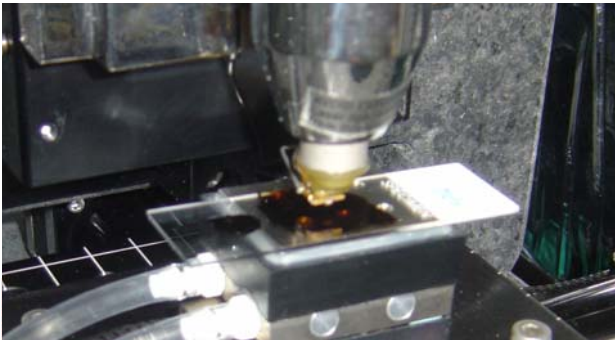
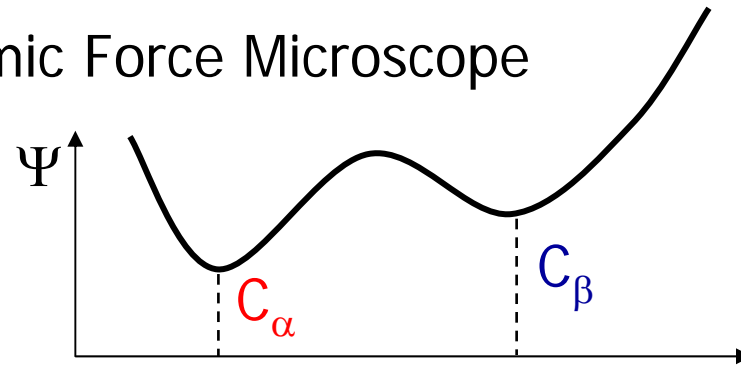
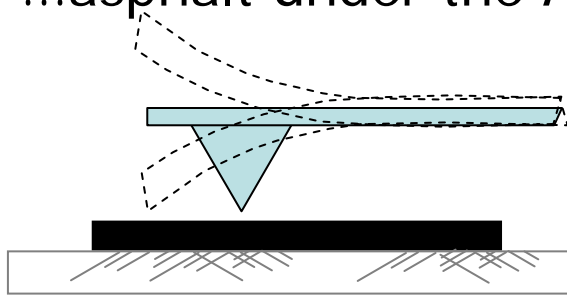

...asphalt under the Atomic Force Microscope

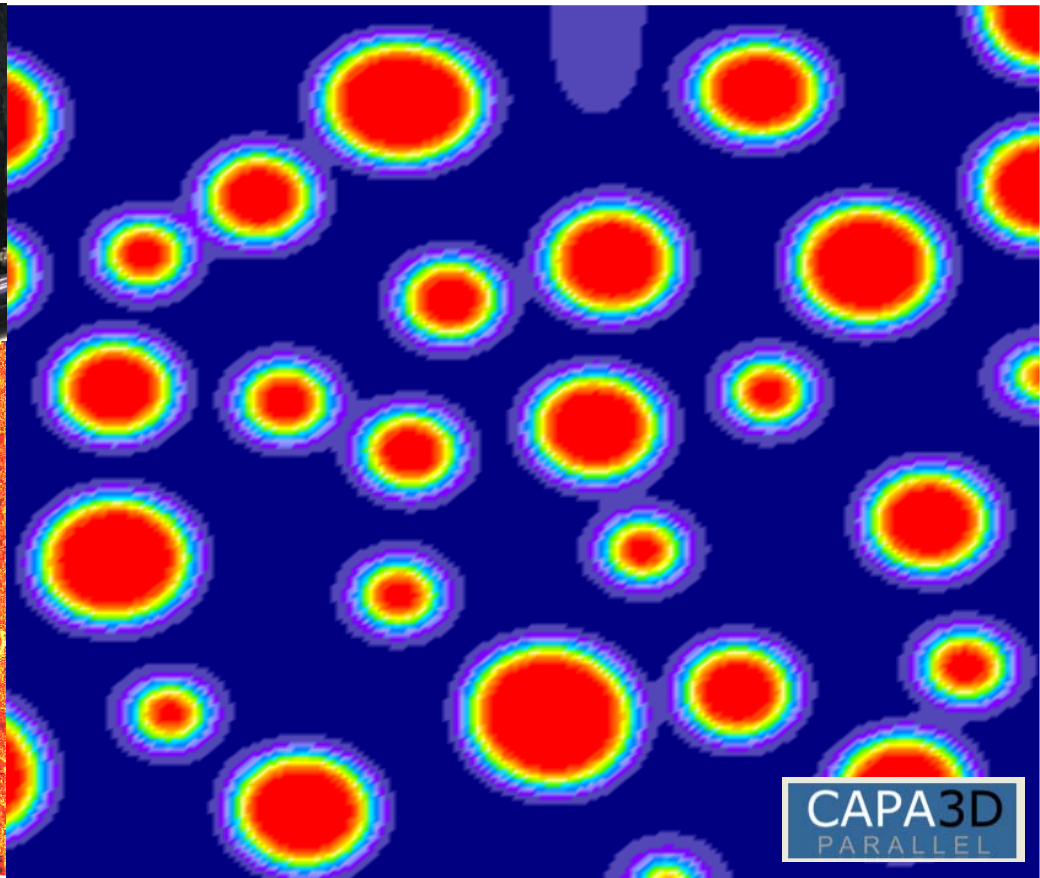
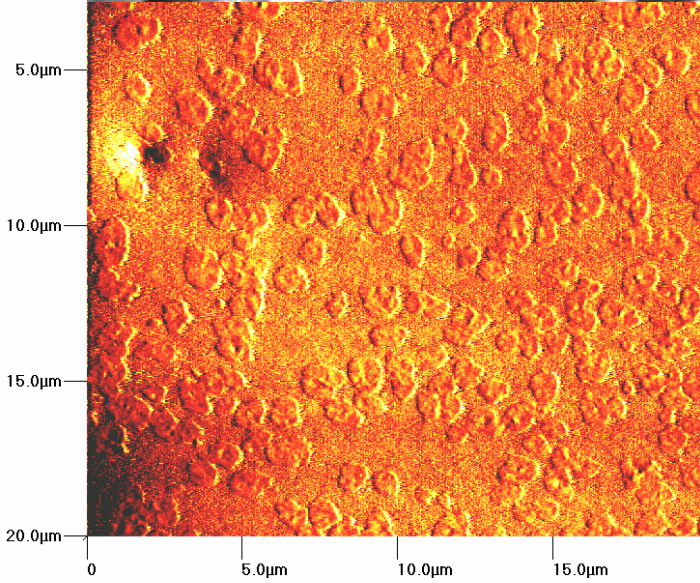
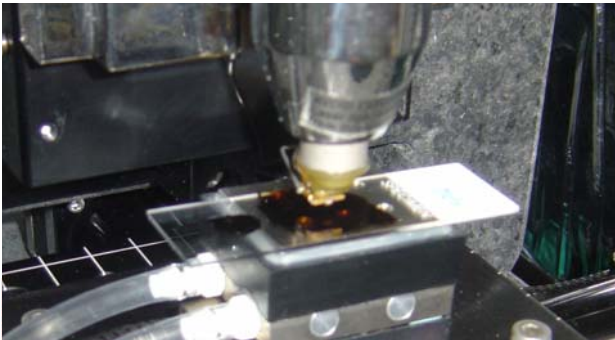
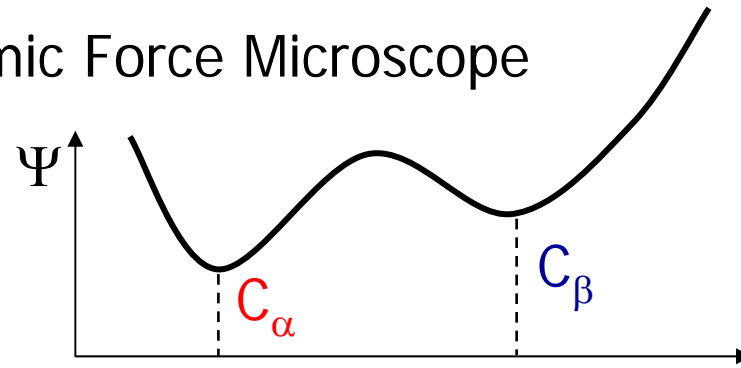
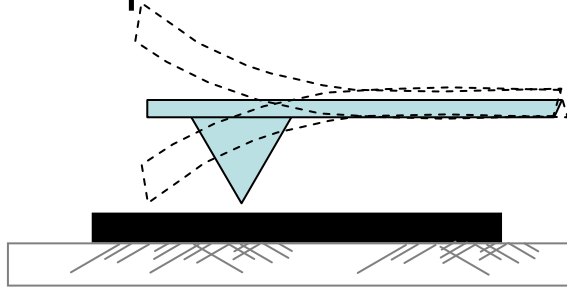

CAPA3D
PARALLEL

C_α

C_β

...asphalt under the Atomic Force Microscope

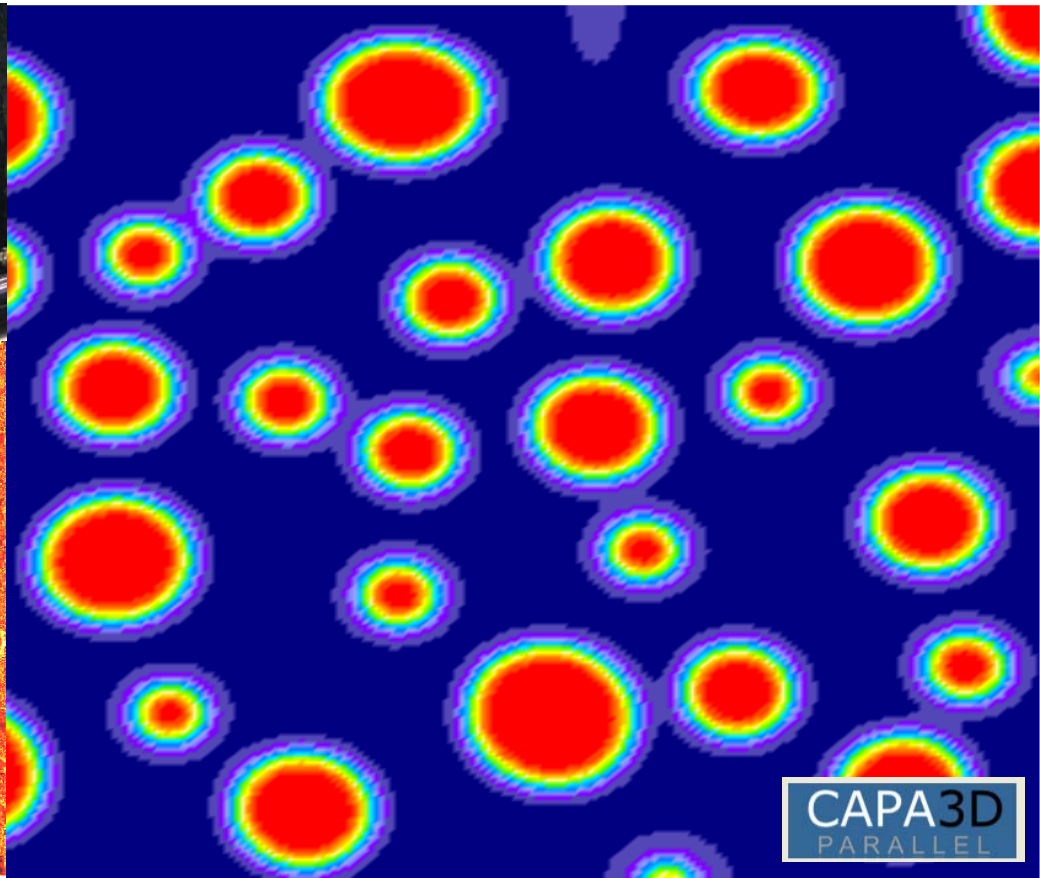
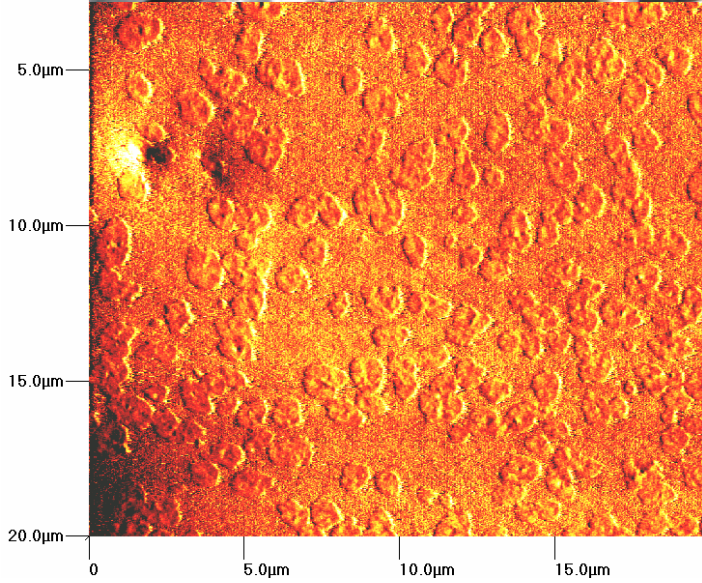
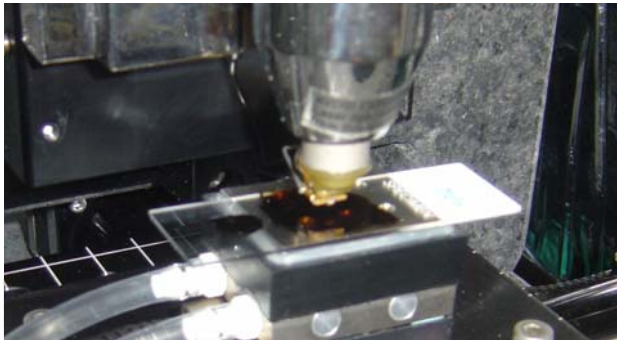
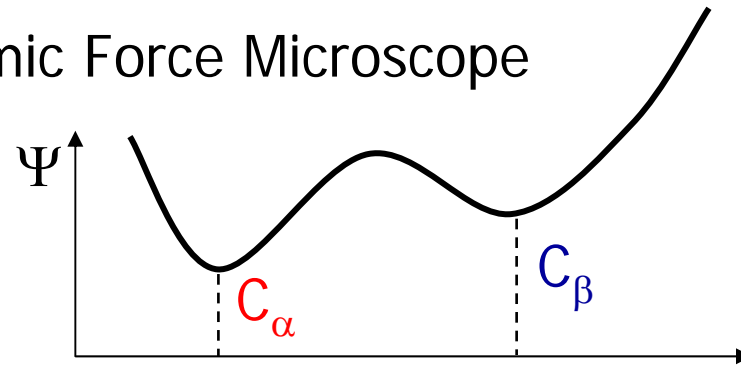
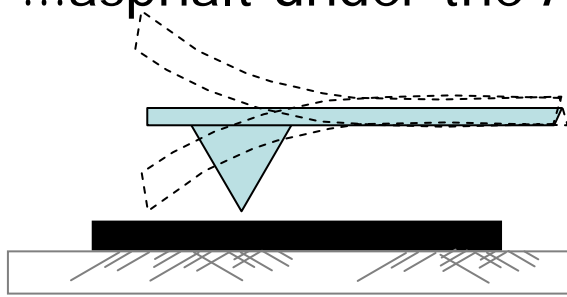

CAPA3D
PARALLEL

C_α
 C_β

...asphalt under the Atomic Force Microscope

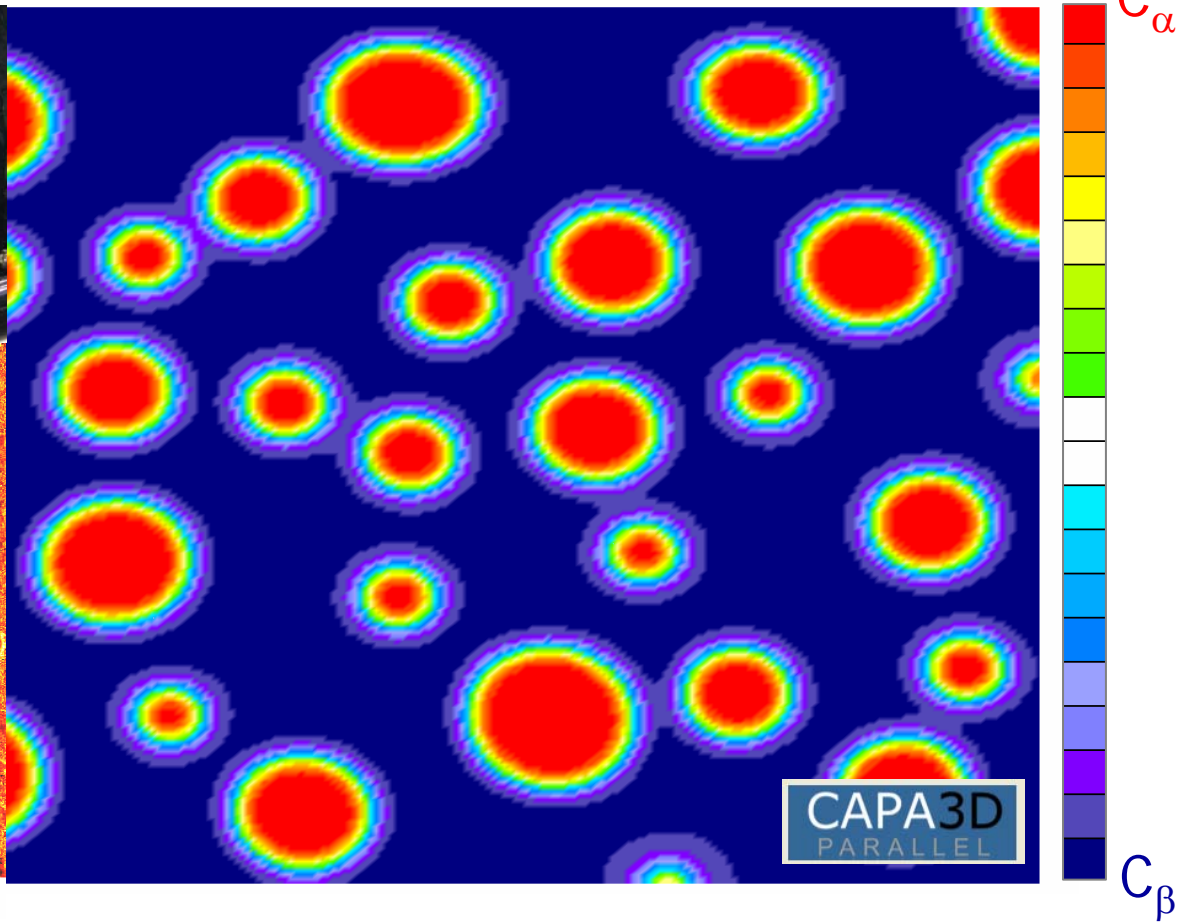
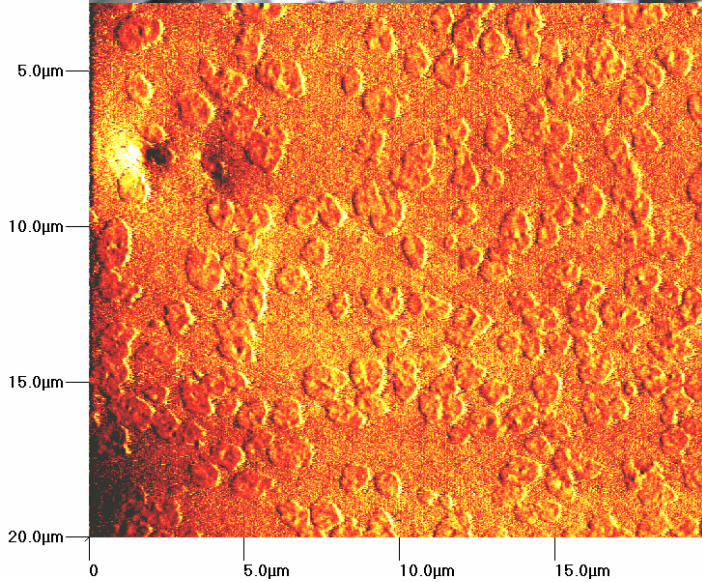
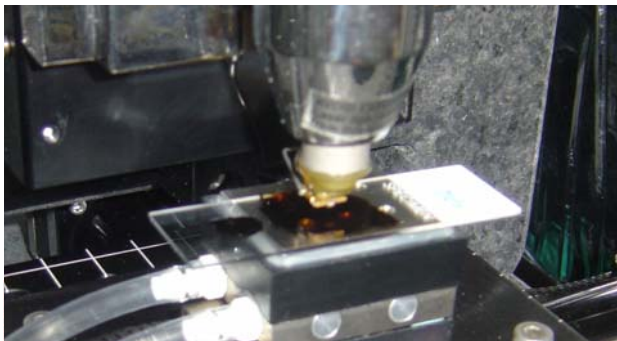
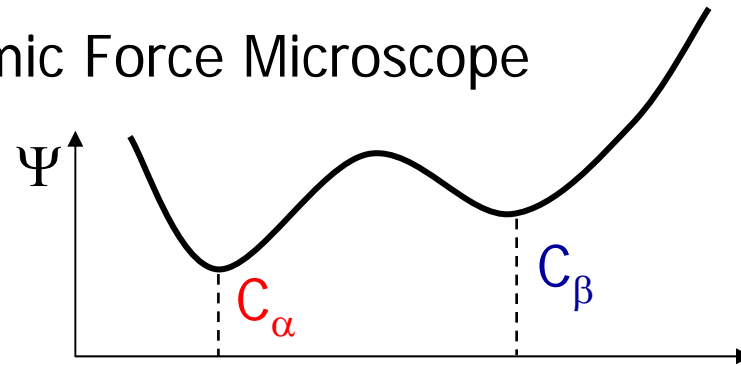
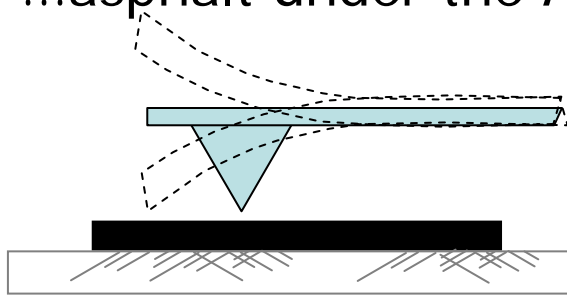

...asphalt under the Atomic Force Microscope

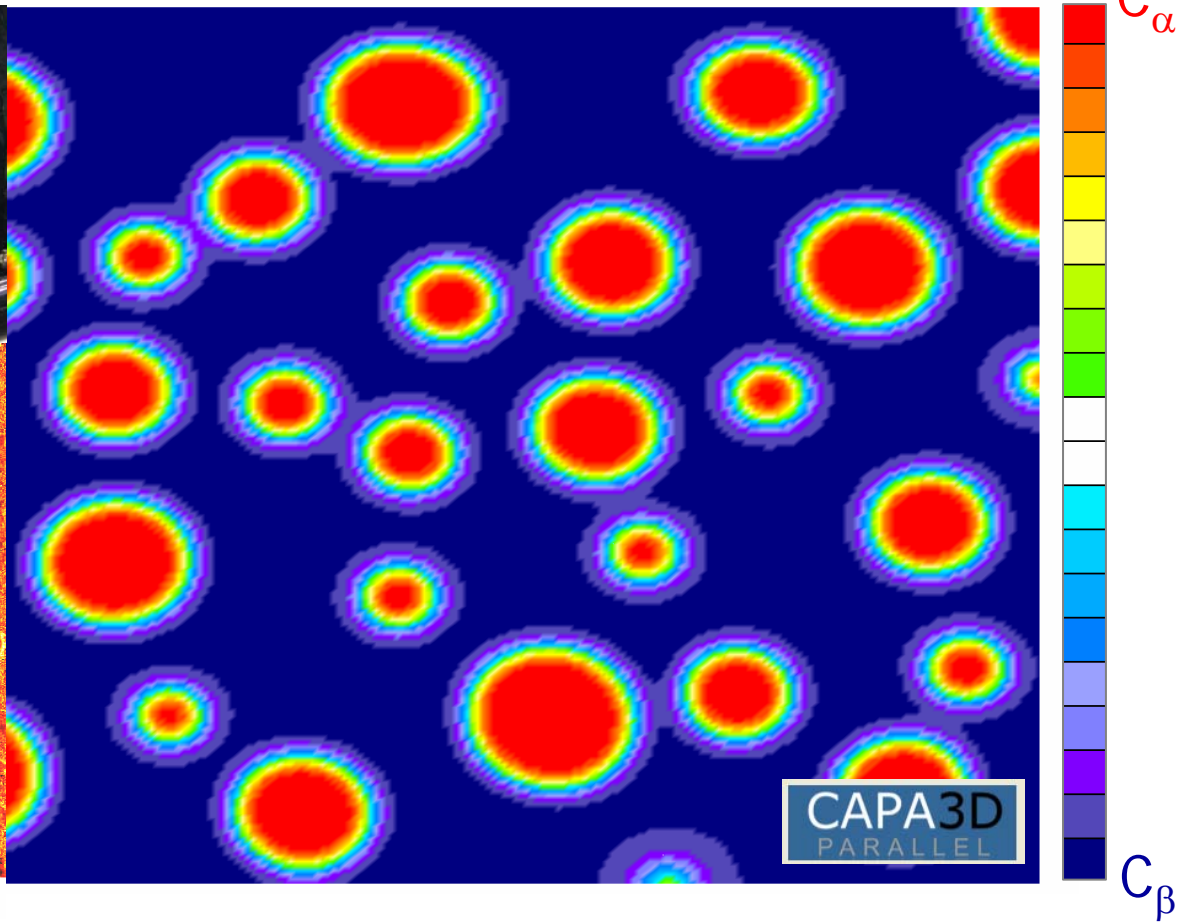
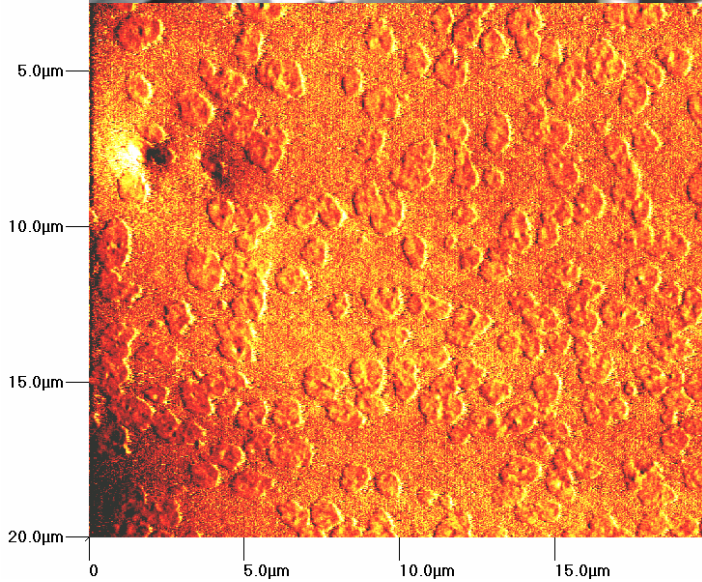
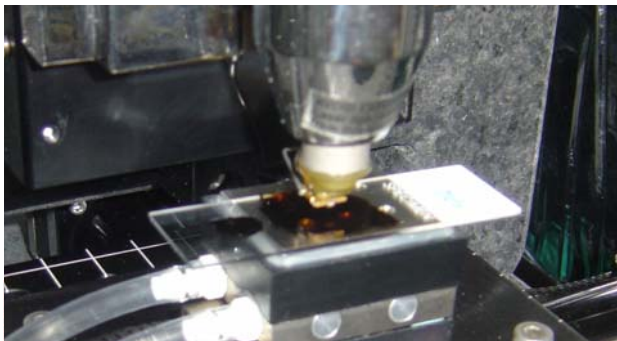
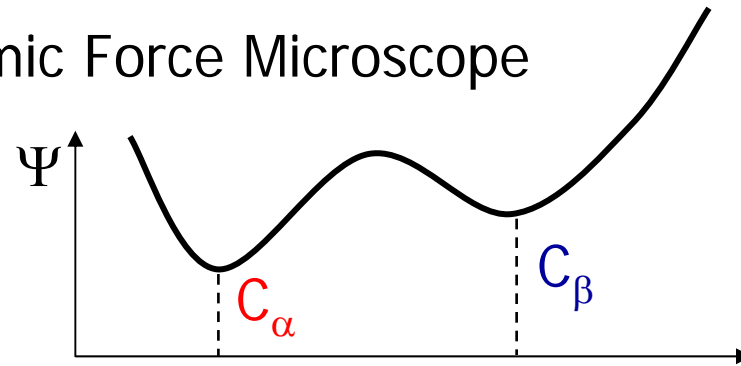
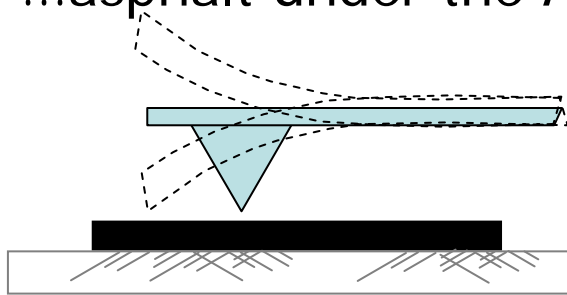

...asphalt under the Atomic Force Microscope

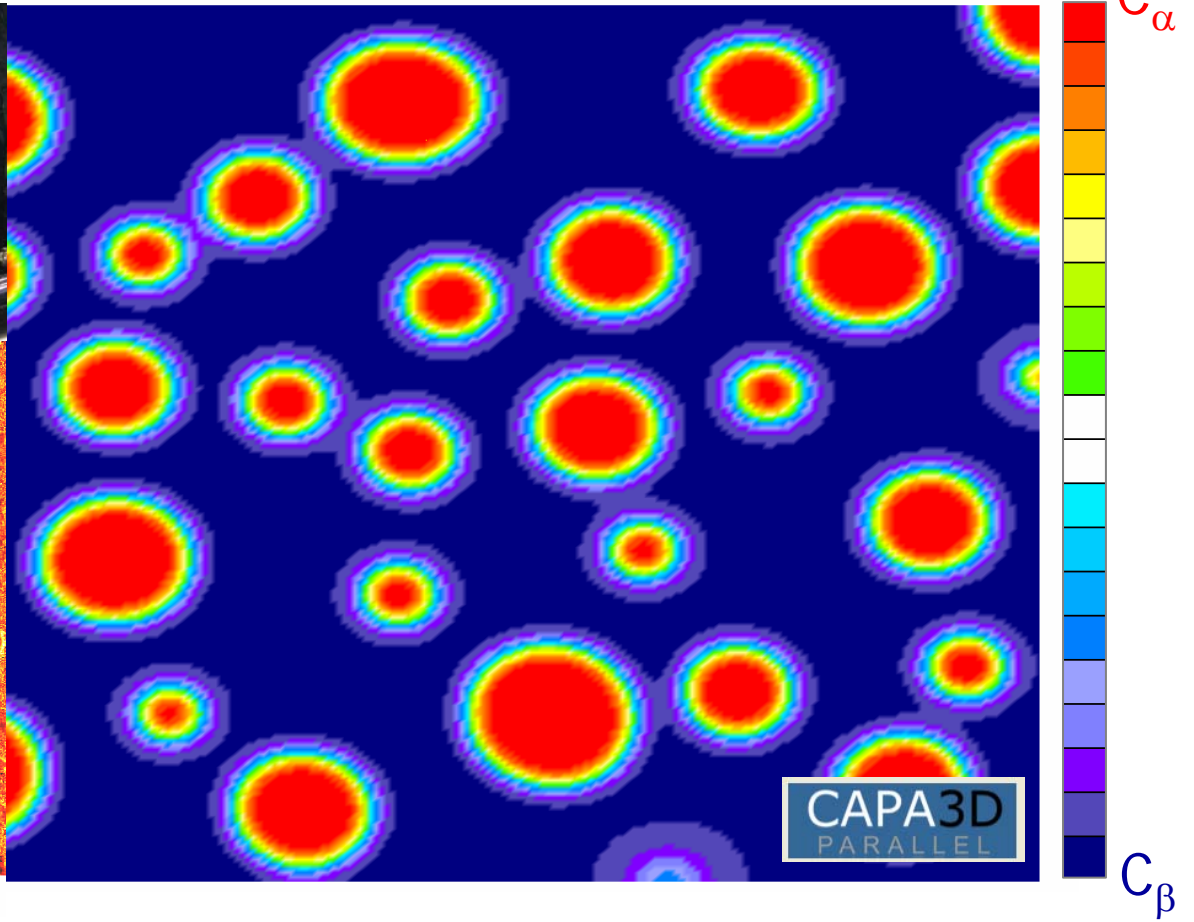
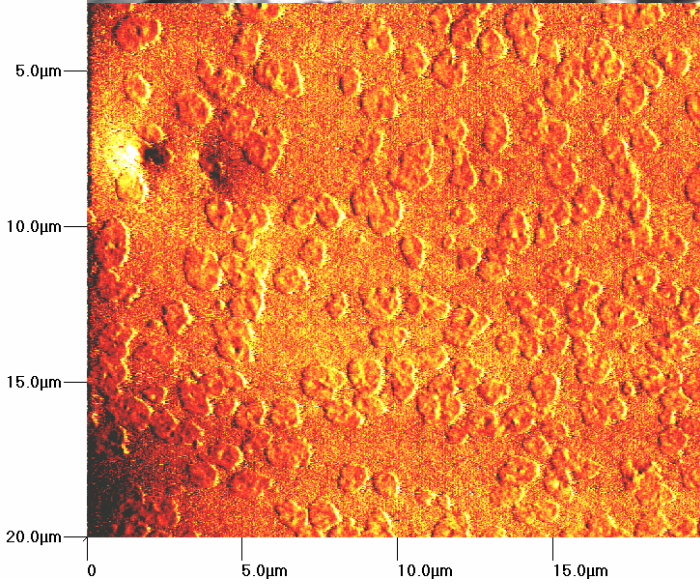
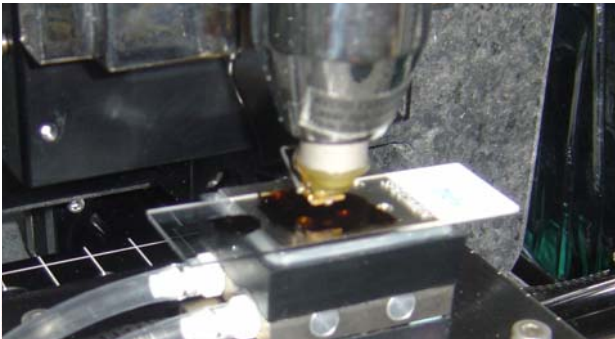
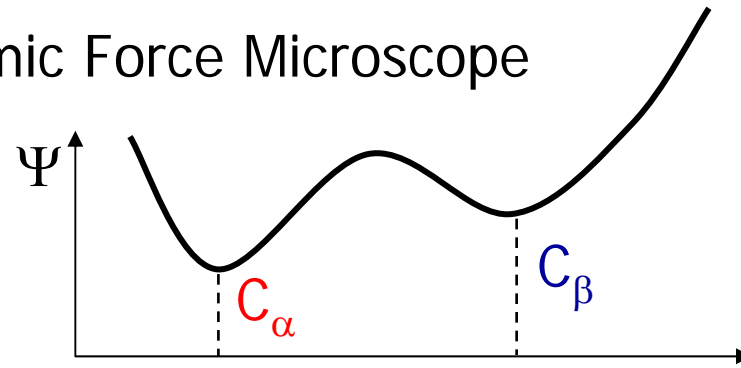
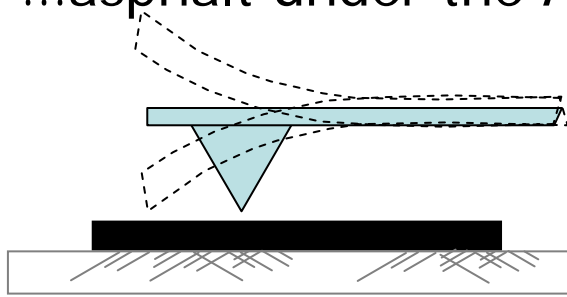

...asphalt under the Atomic Force Microscope

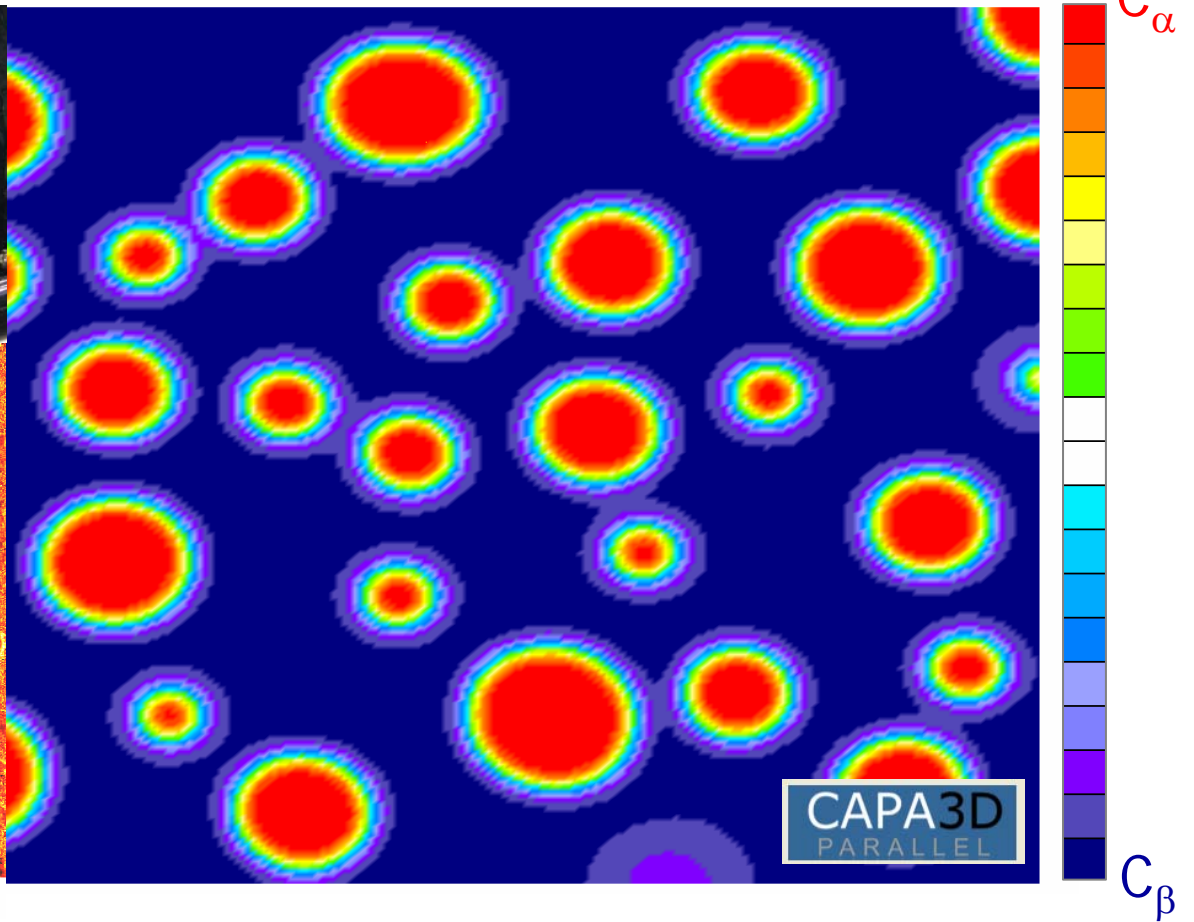
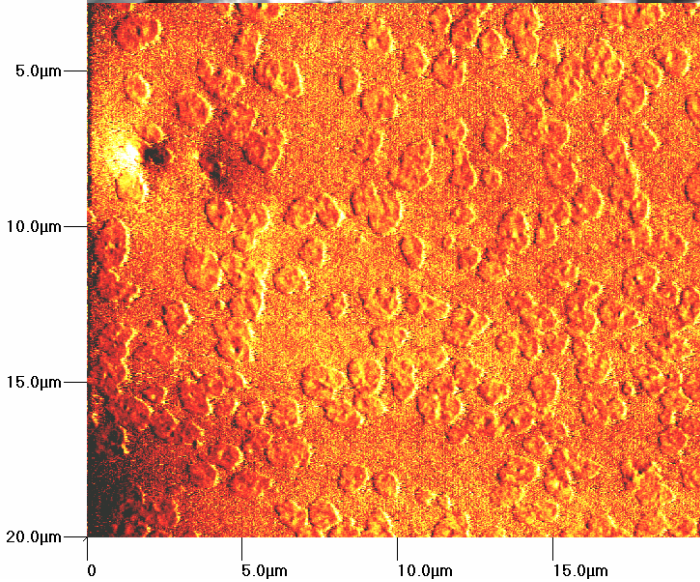
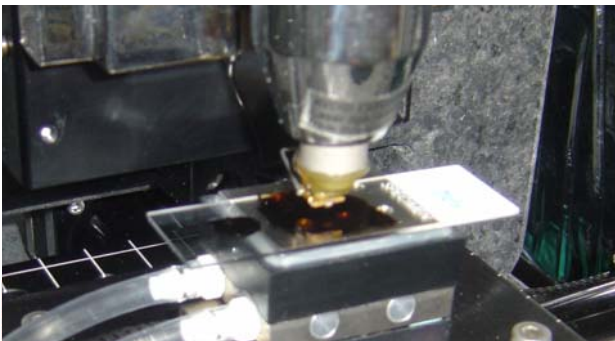
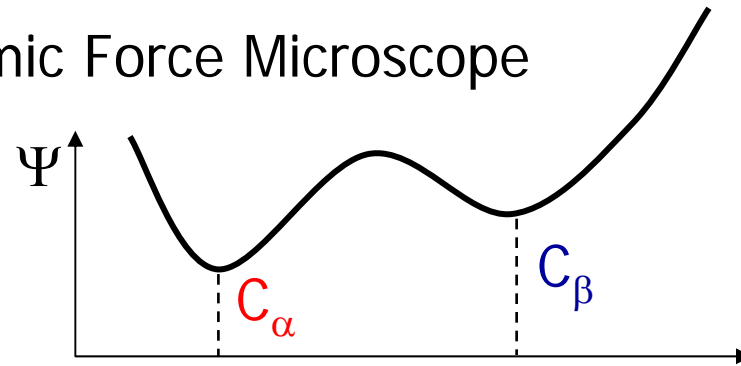
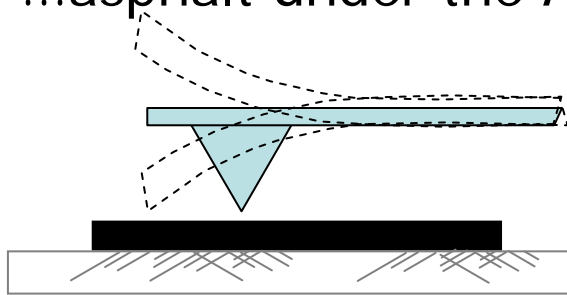

...asphalt under the Atomic Force Microscope

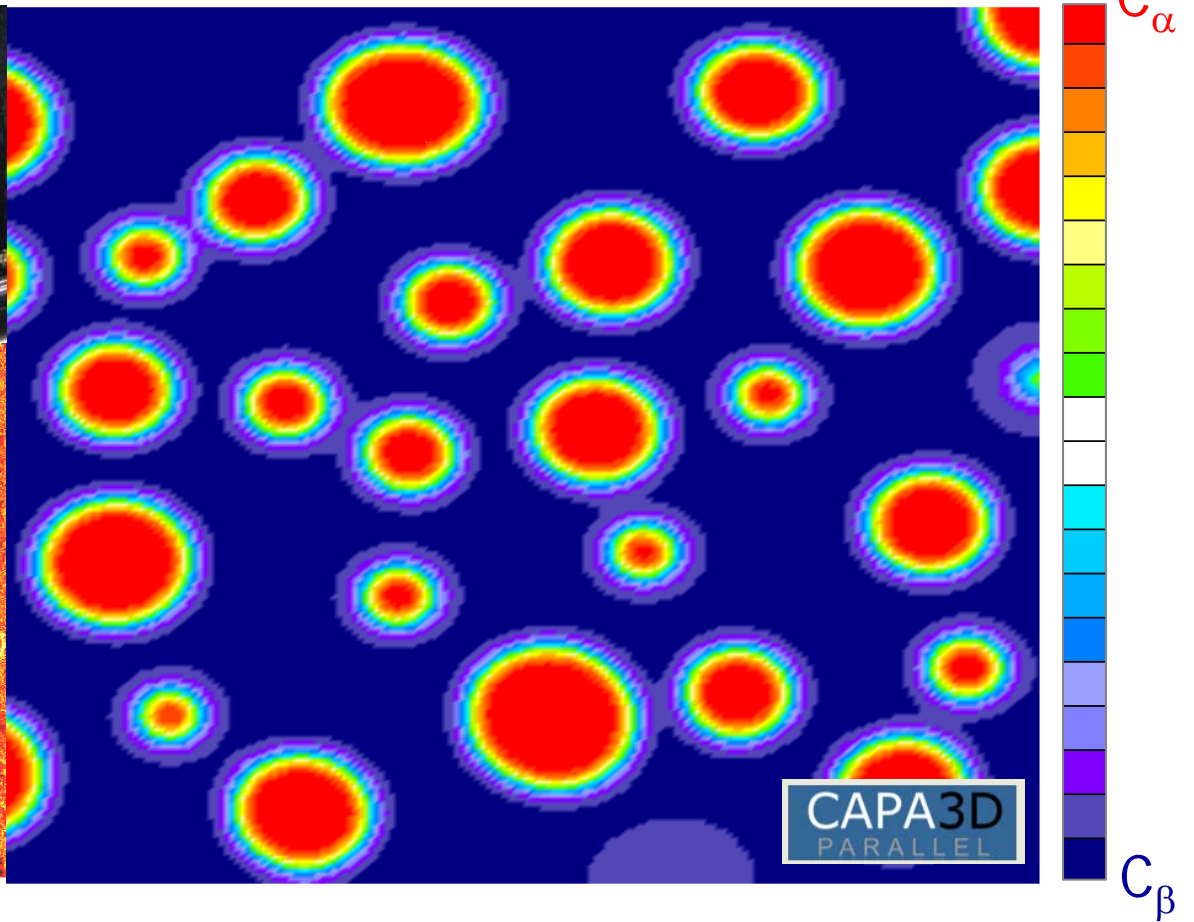
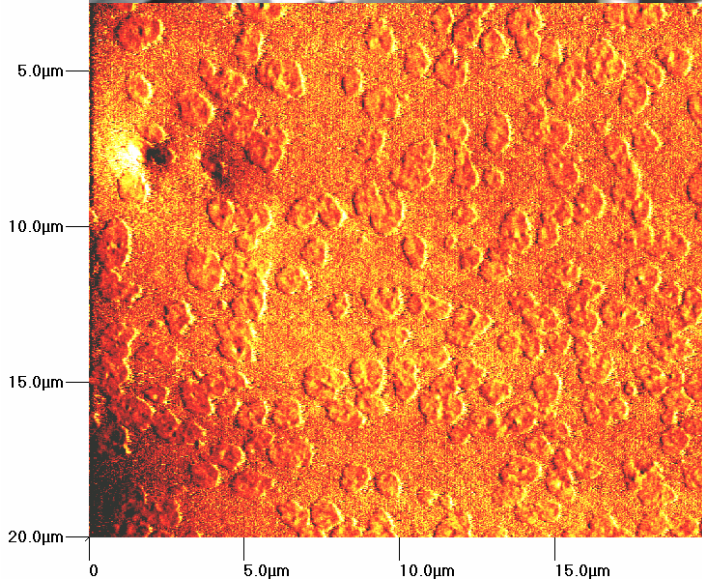
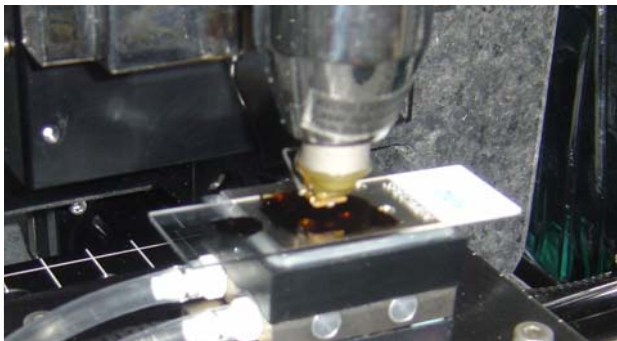
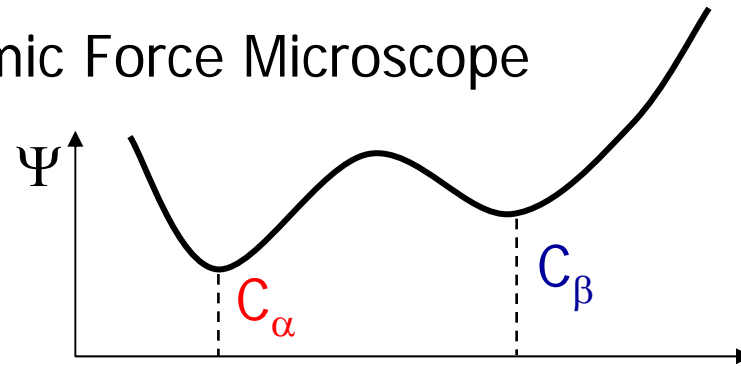
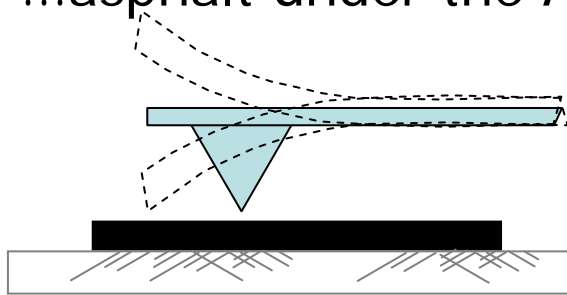

...asphalt under the Atomic Force Microscope

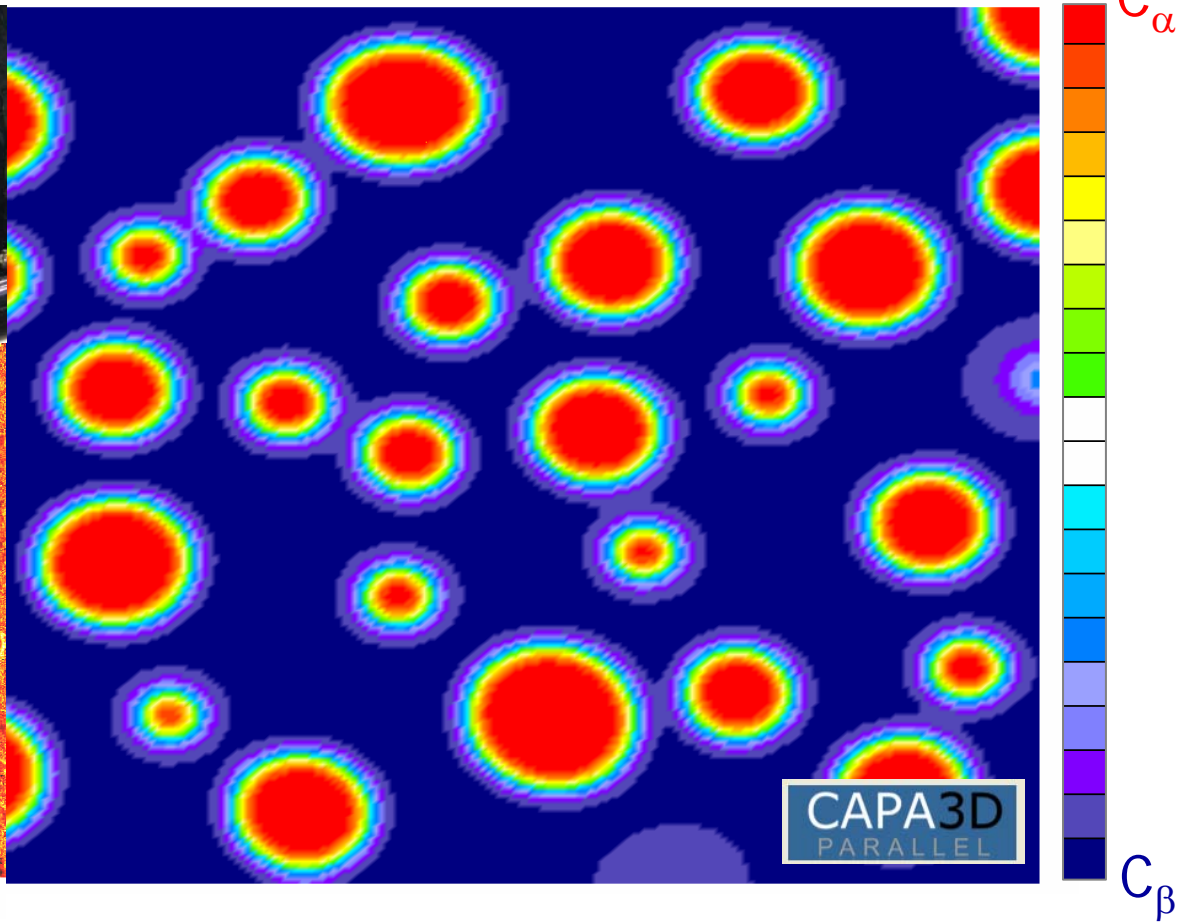
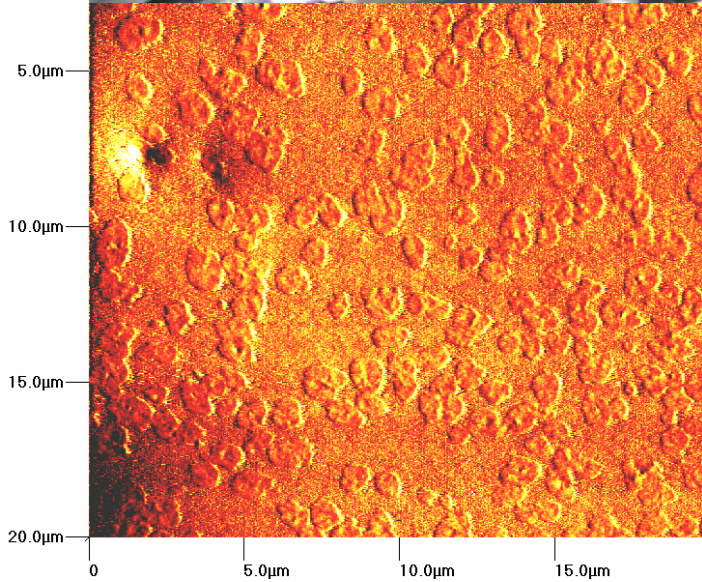
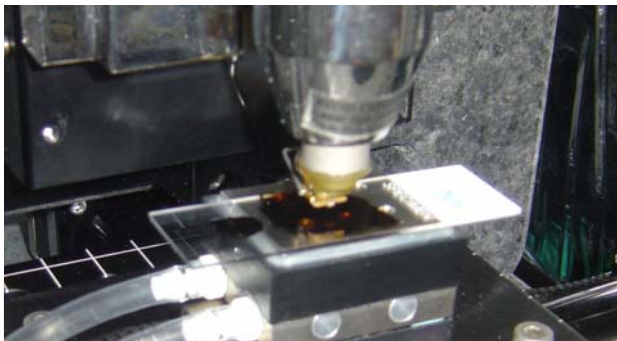
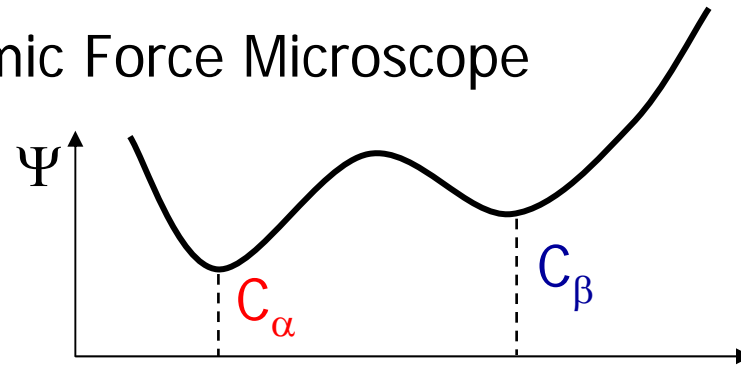
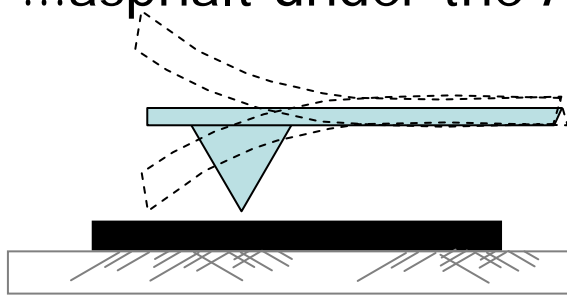

...asphalt under the Atomic Force Microscope

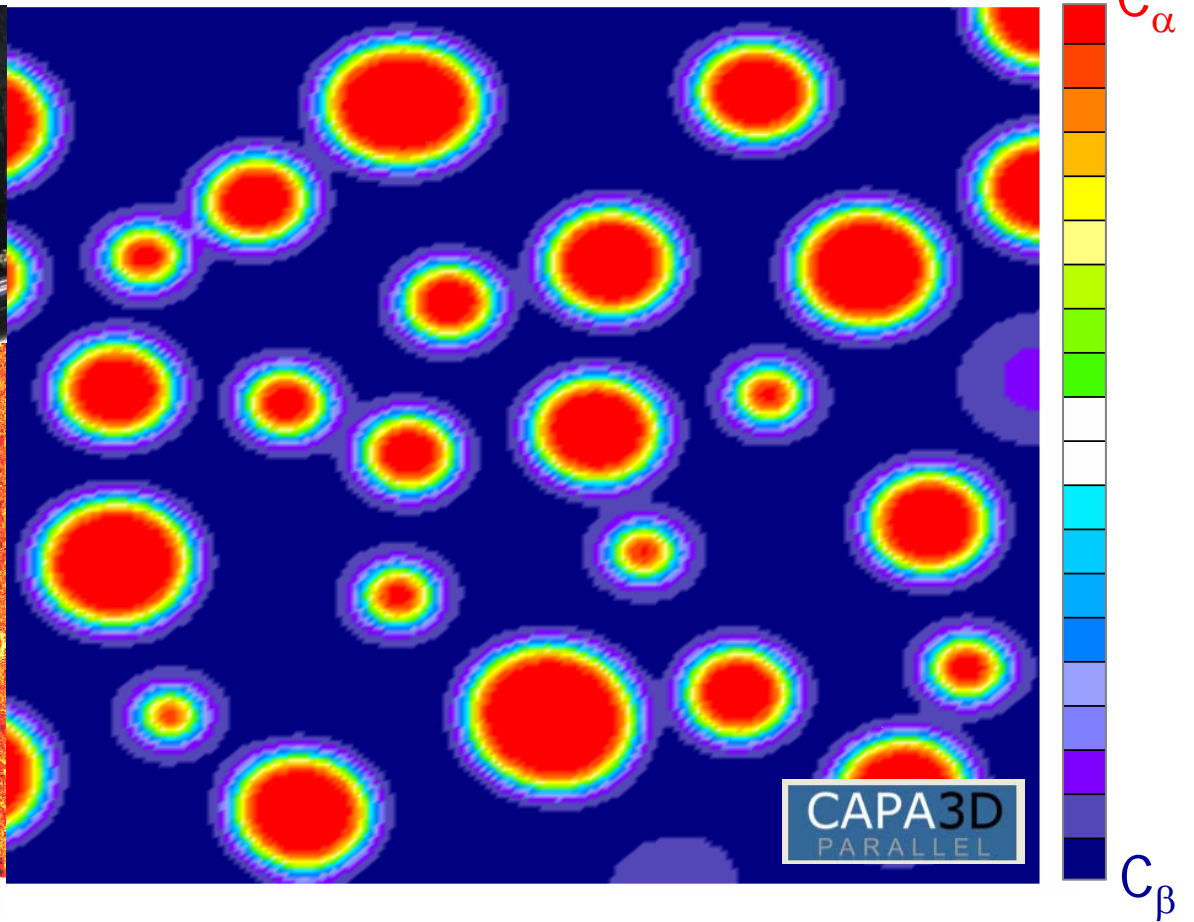
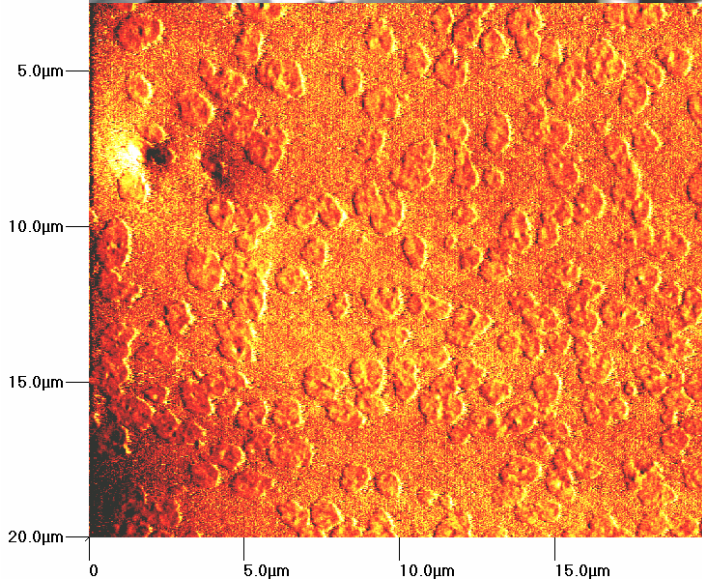
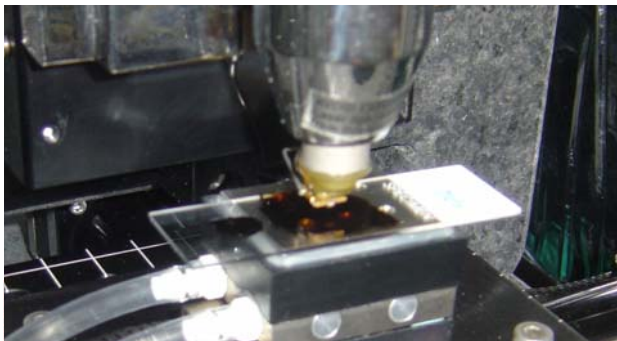
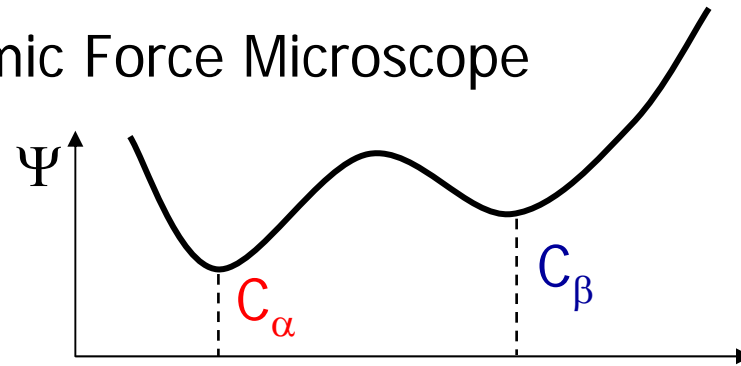
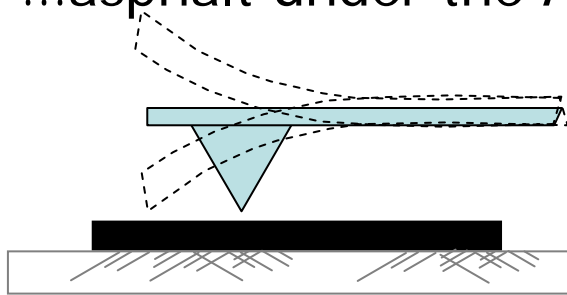

...asphalt under the Atomic Force Microscope

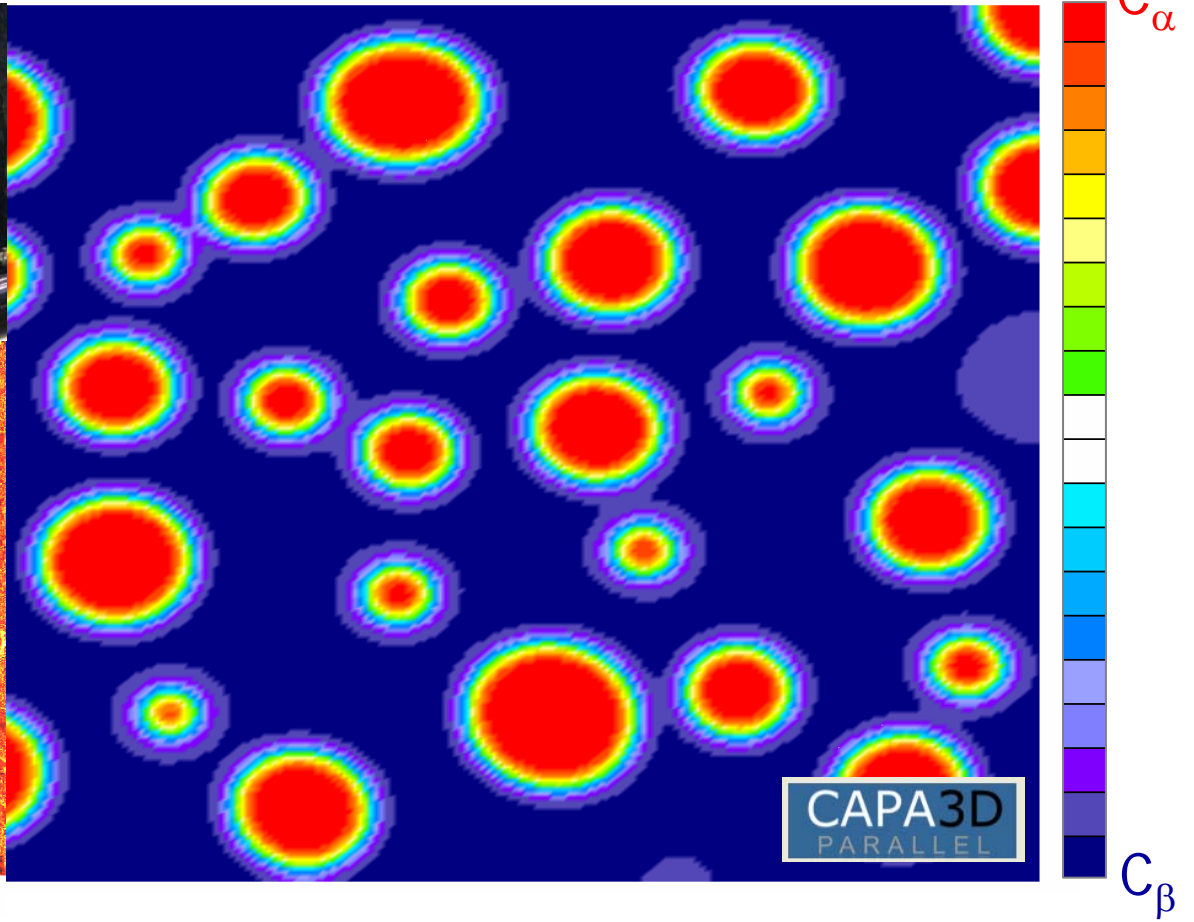
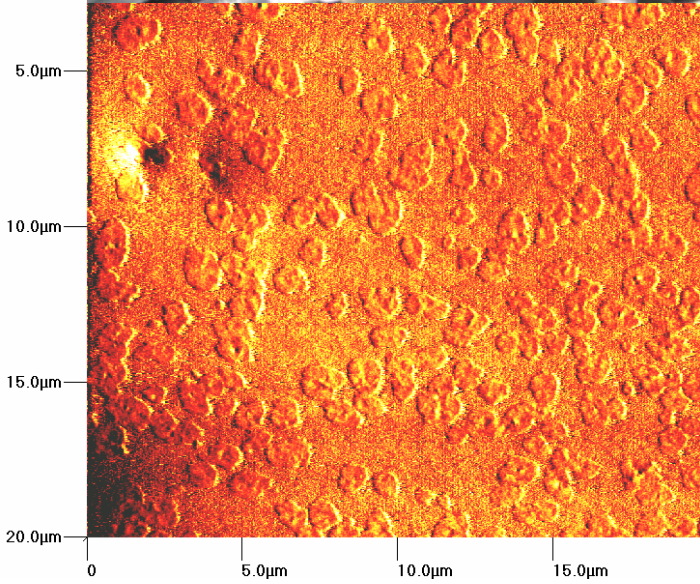
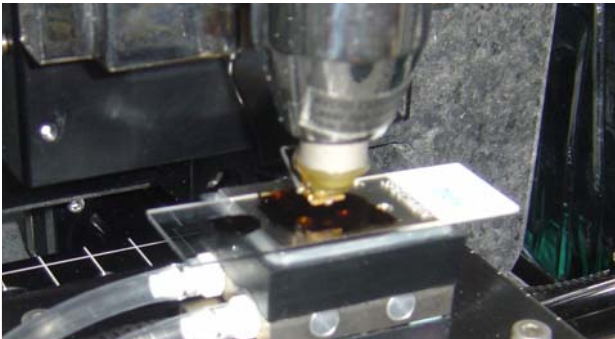
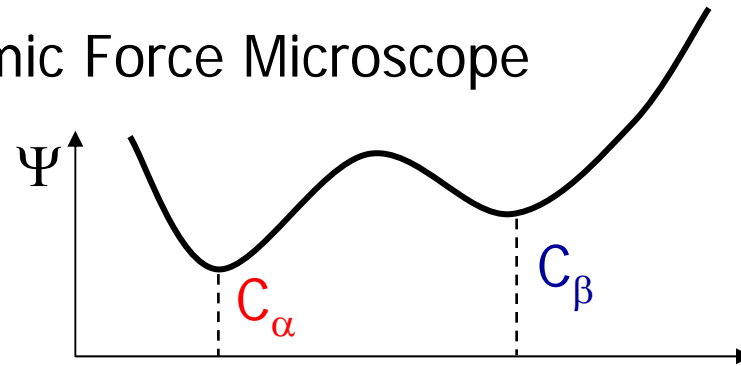
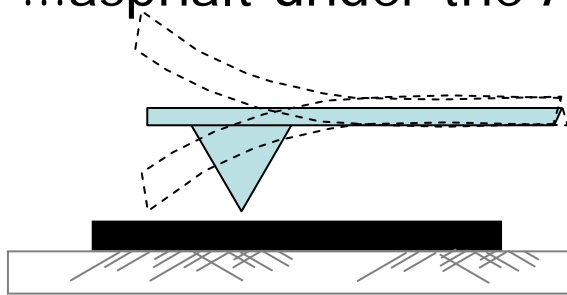

...asphalt under the Atomic Force Microscope

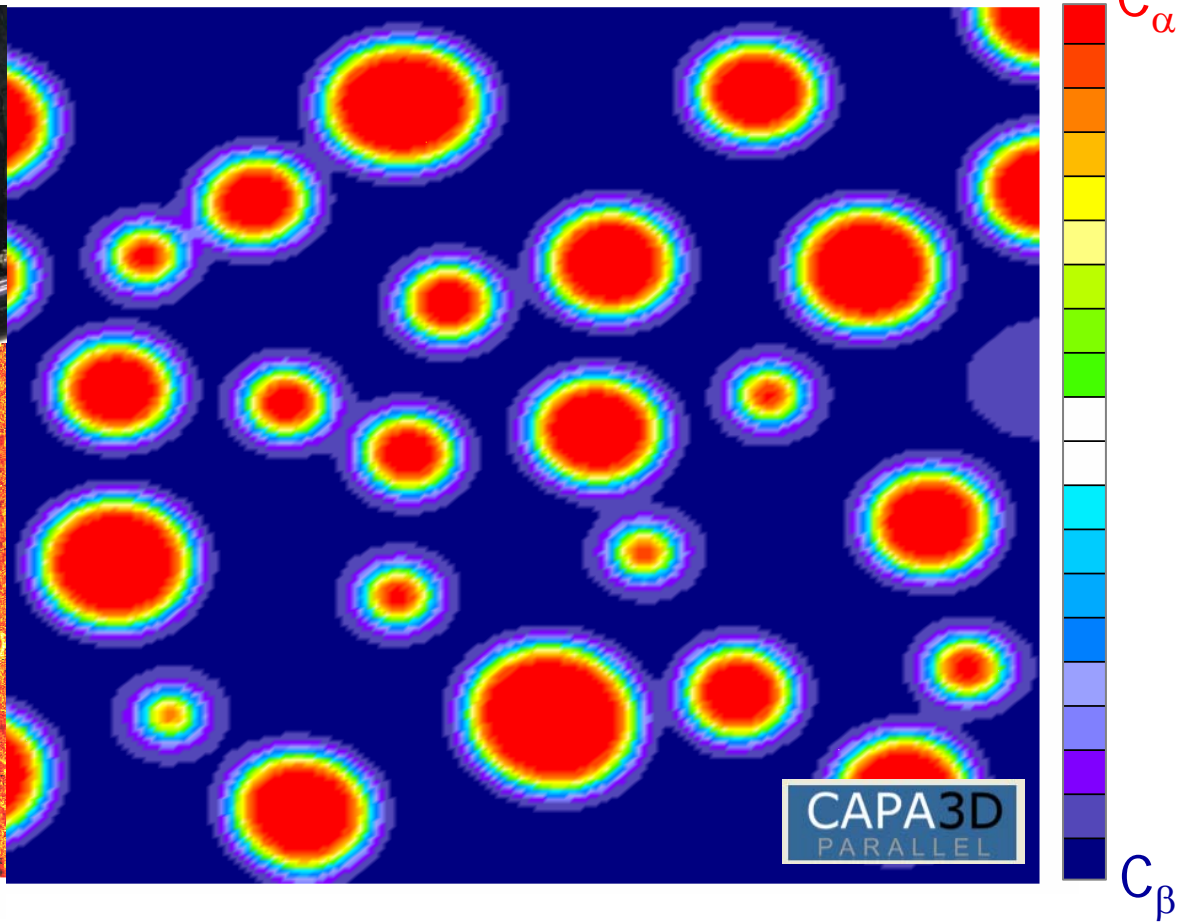
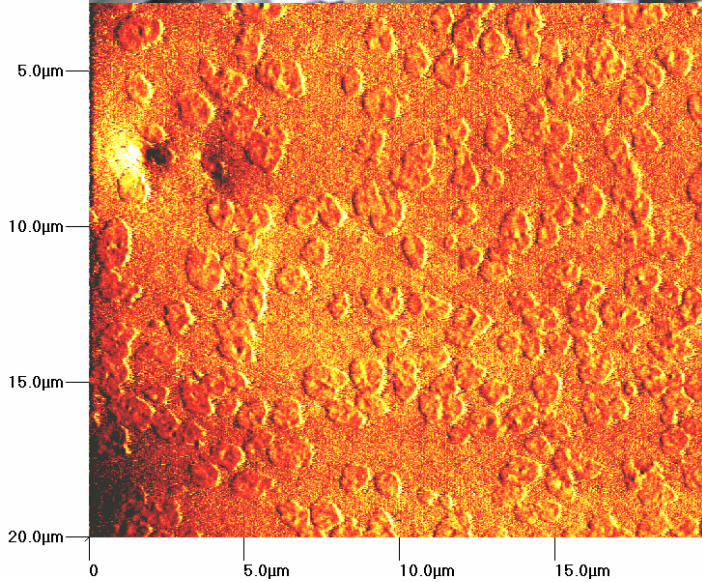
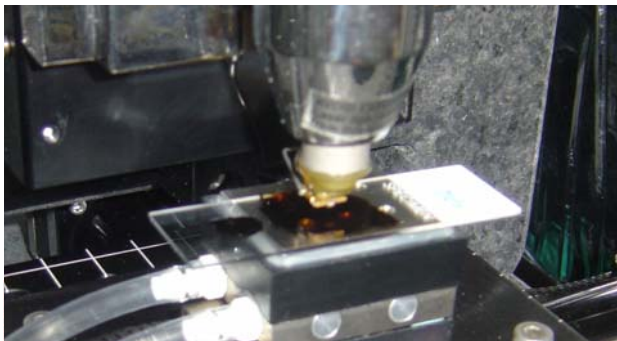
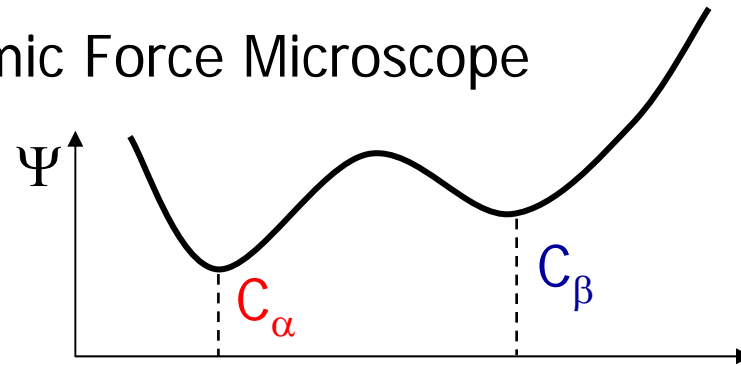
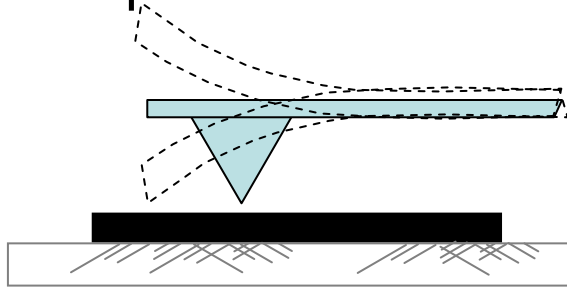

...asphalt under the Atomic Force Microscope

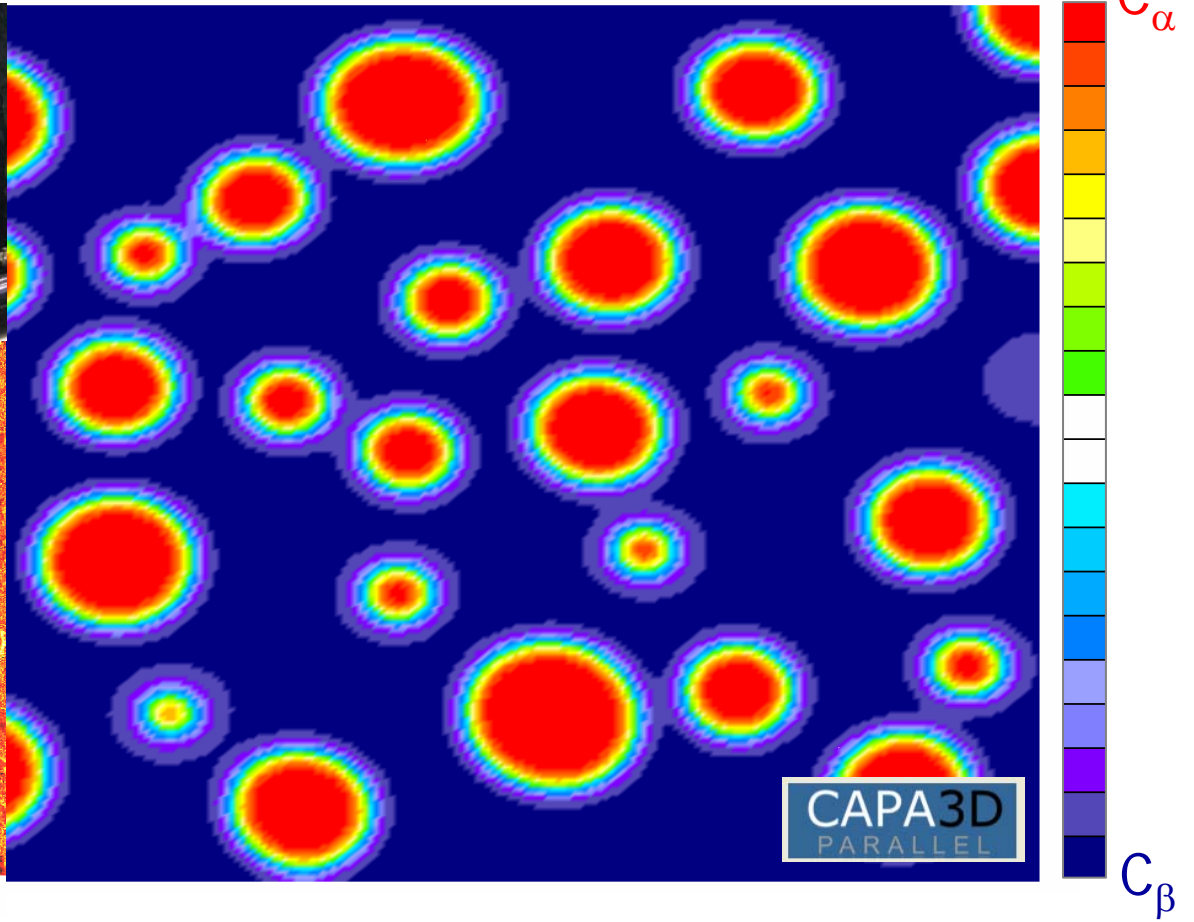
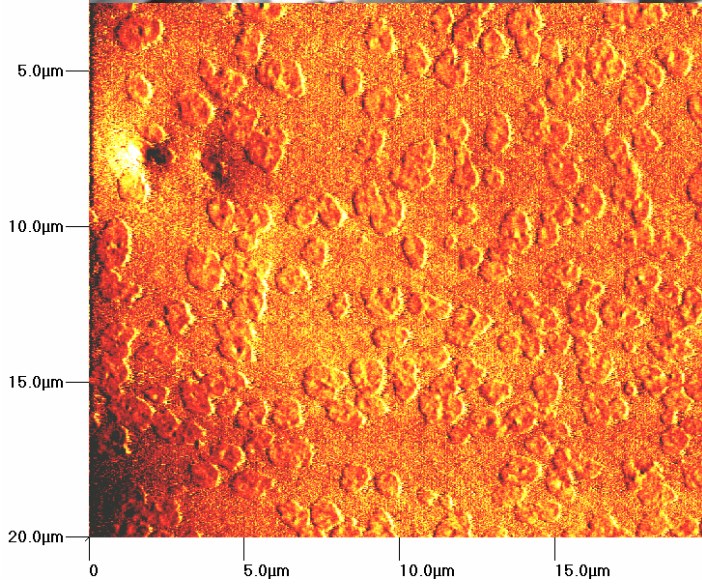
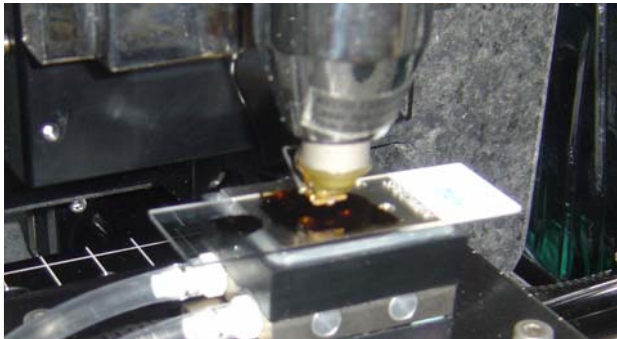
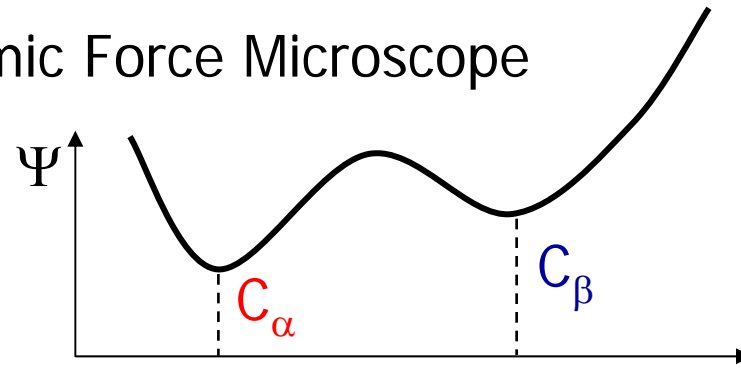
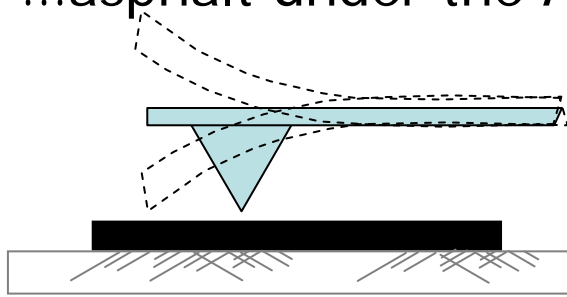

...asphalt under the Atomic Force Microscope

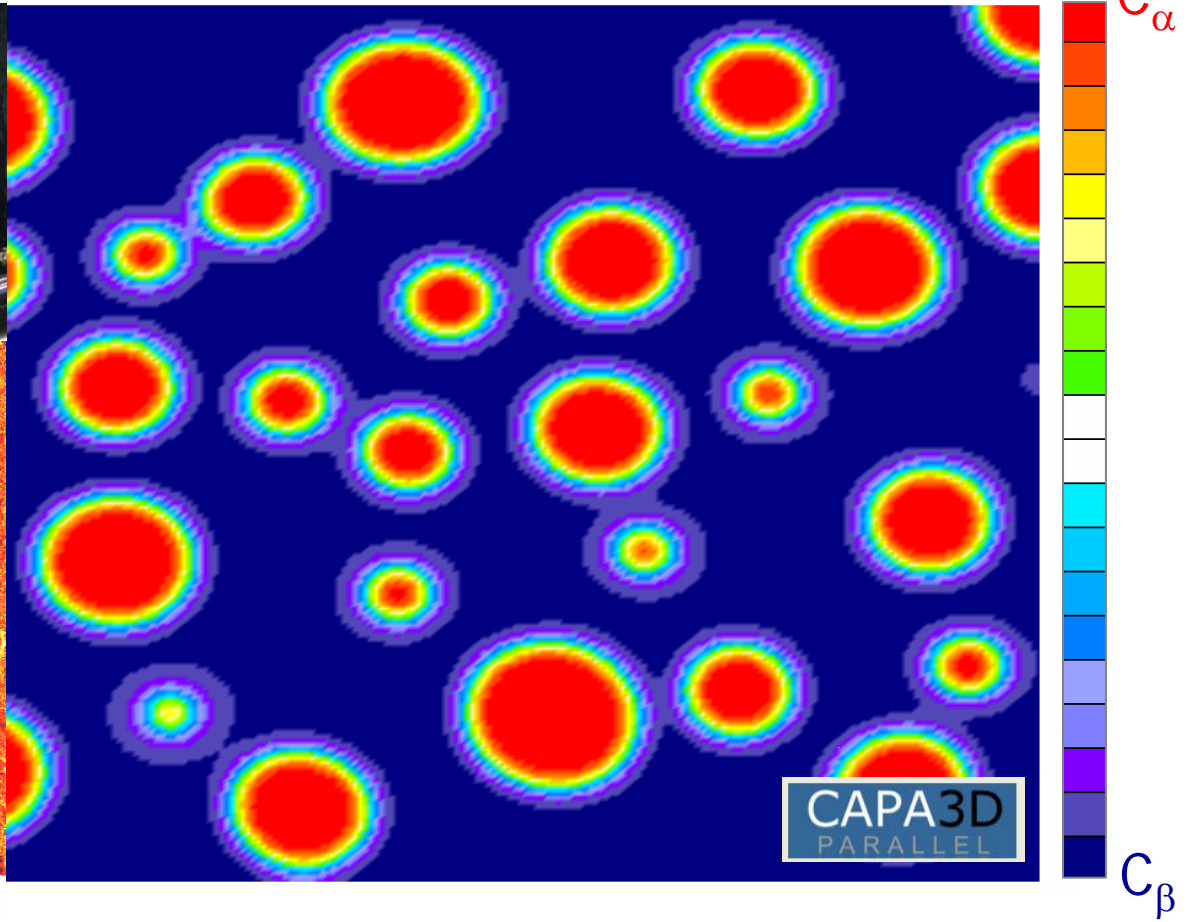
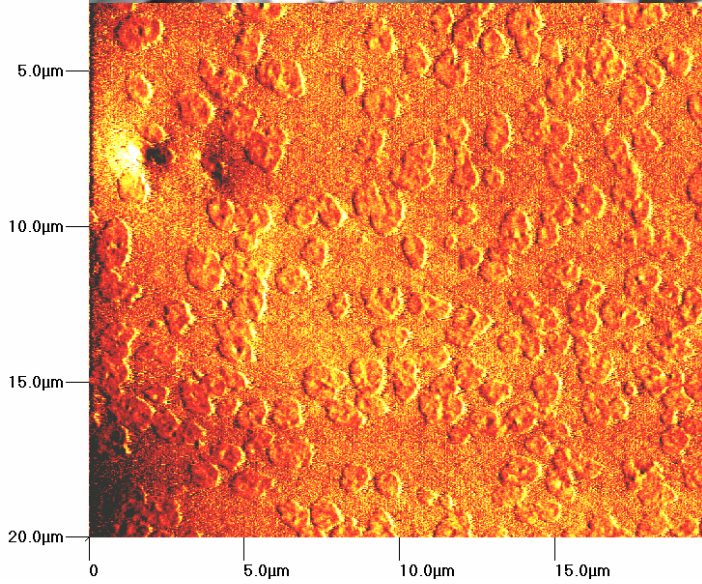
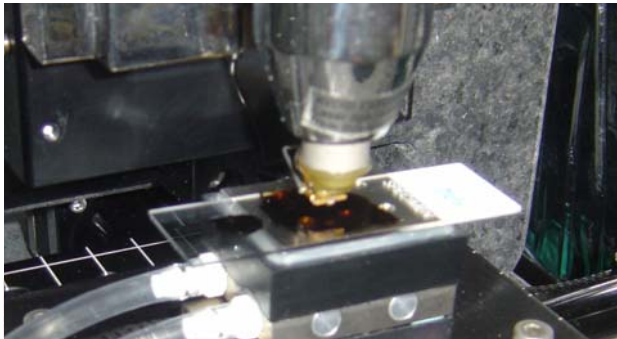
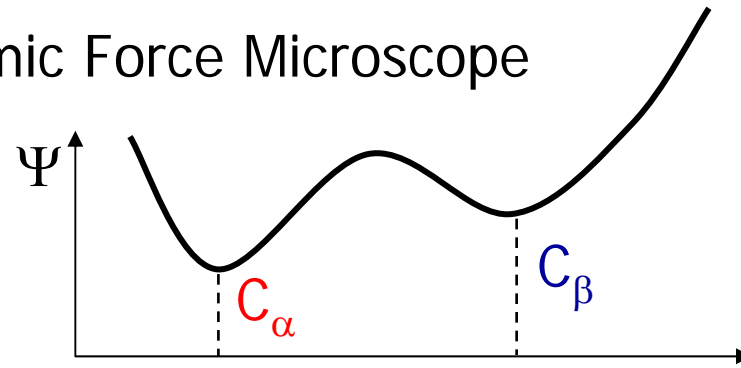
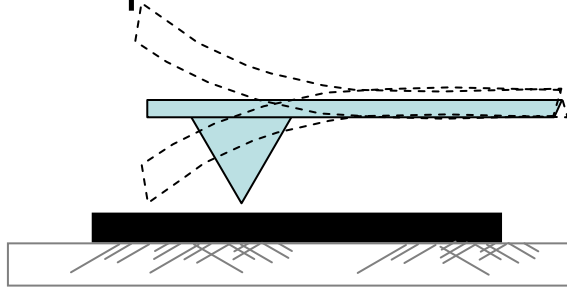

...asphalt under the Atomic Force Microscope

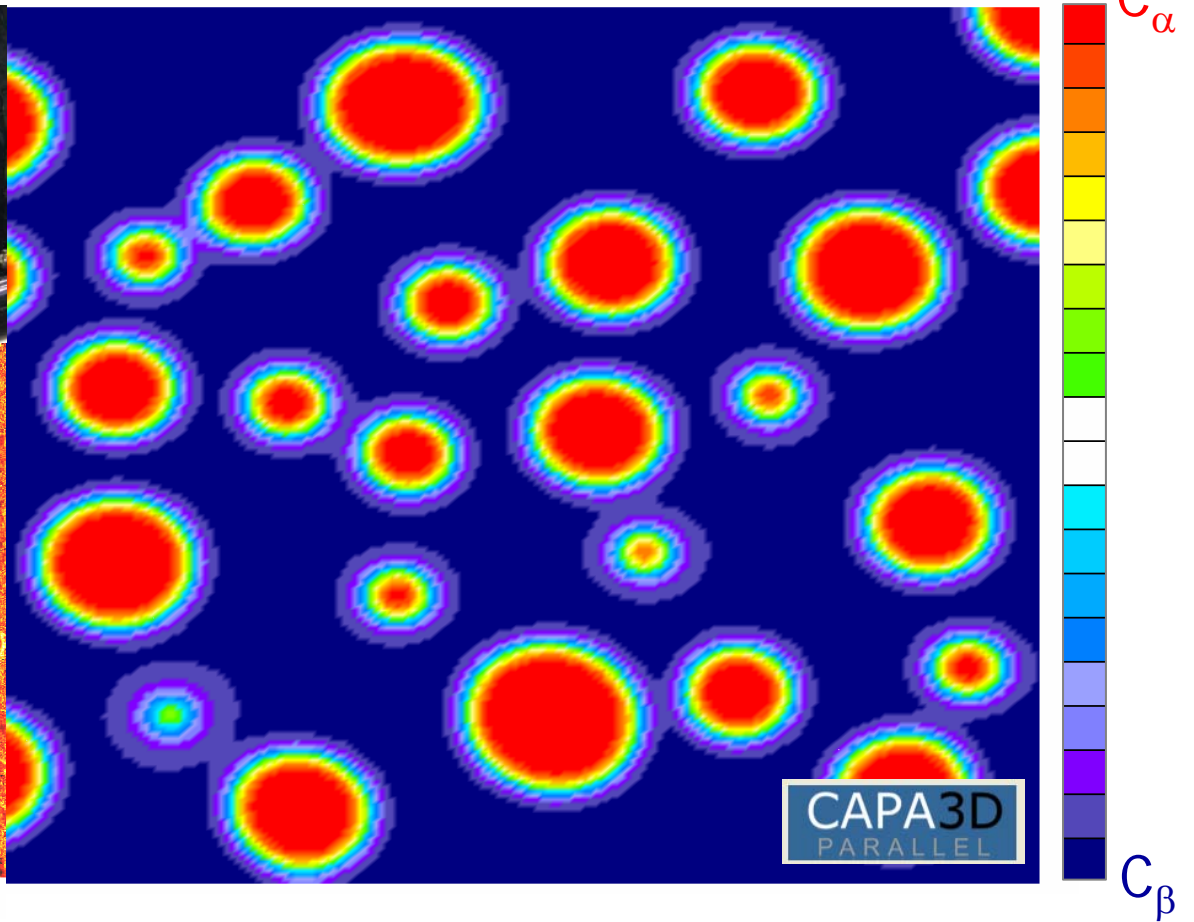
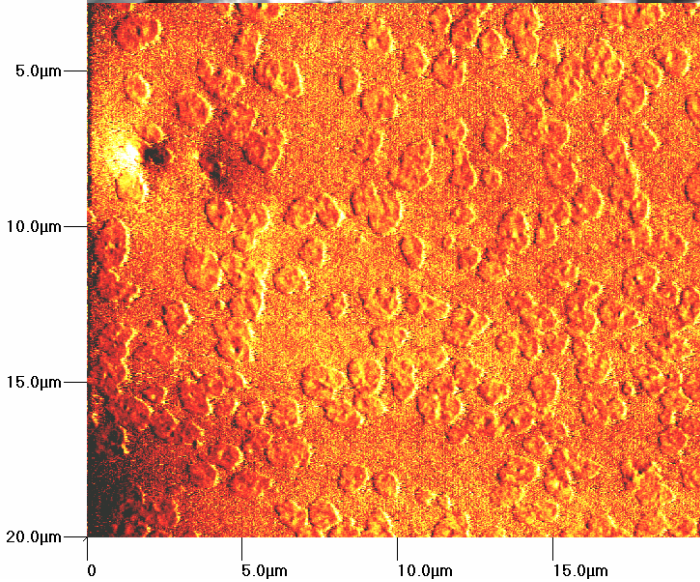
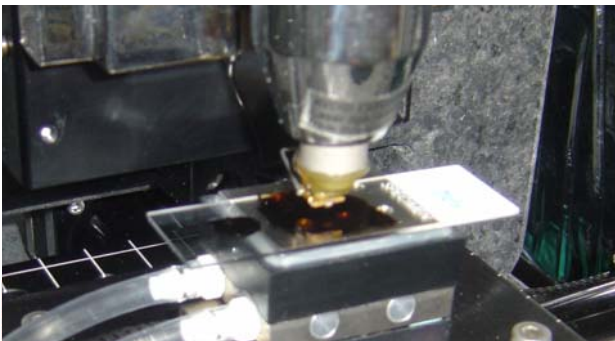
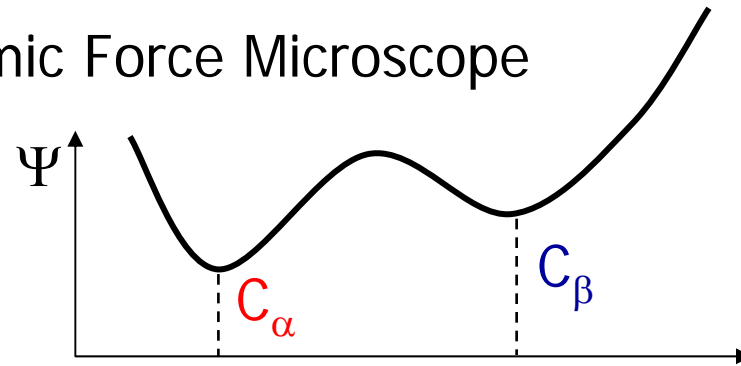
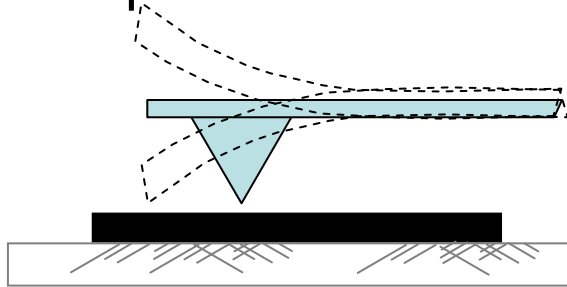

...asphalt under the Atomic Force Microscope

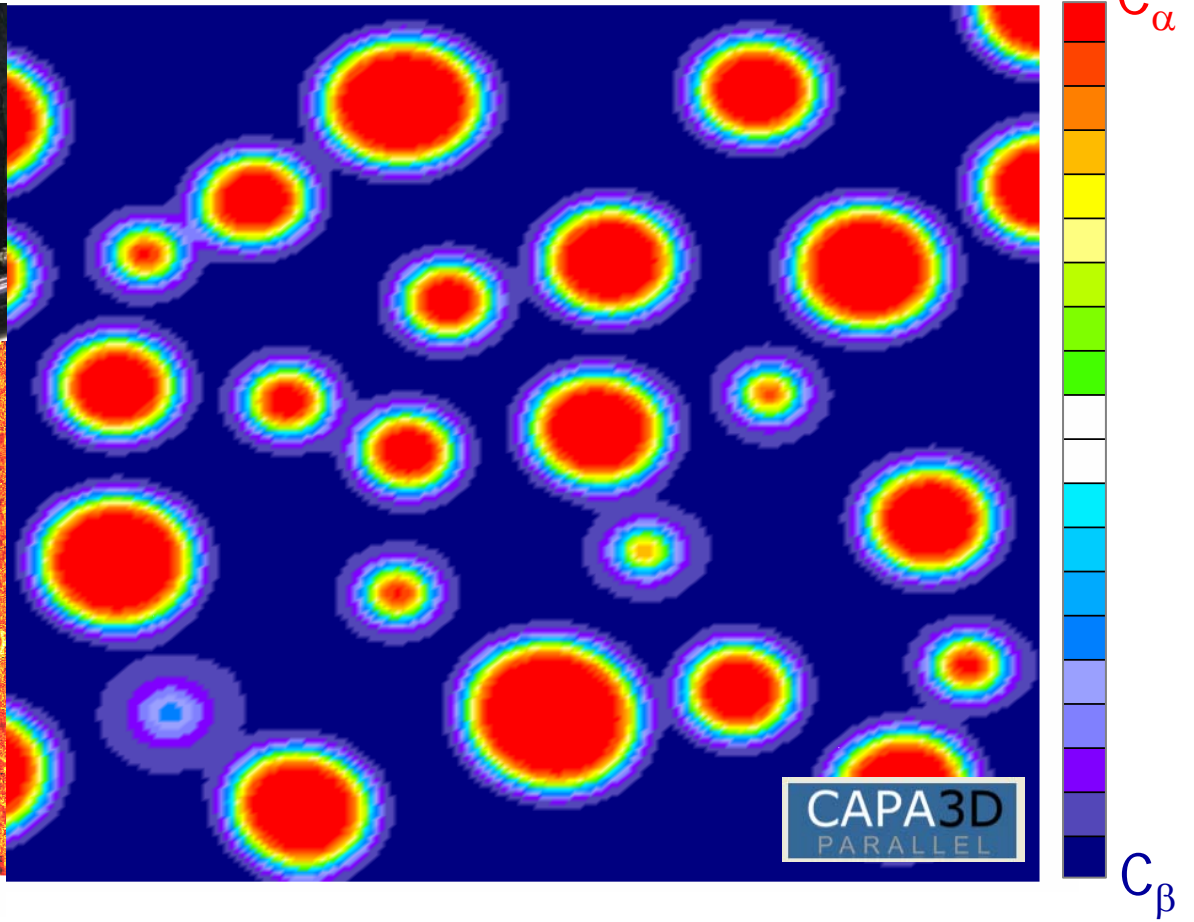
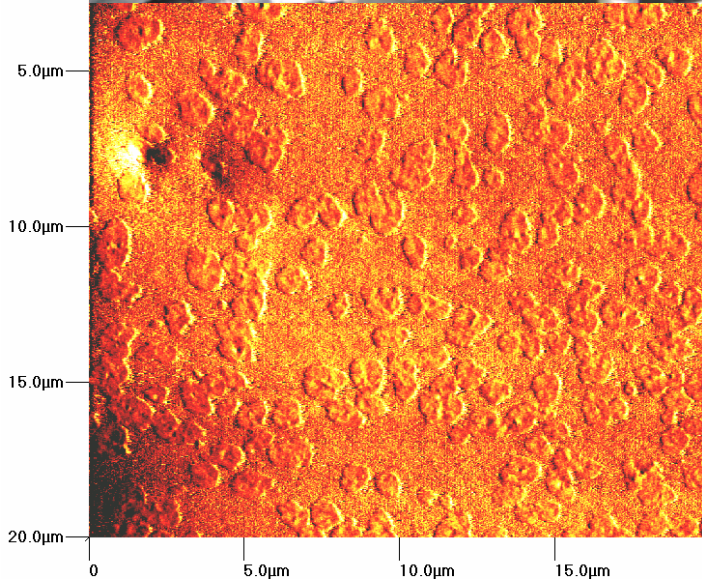
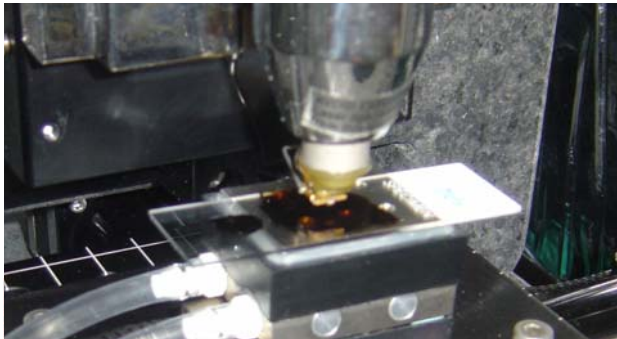
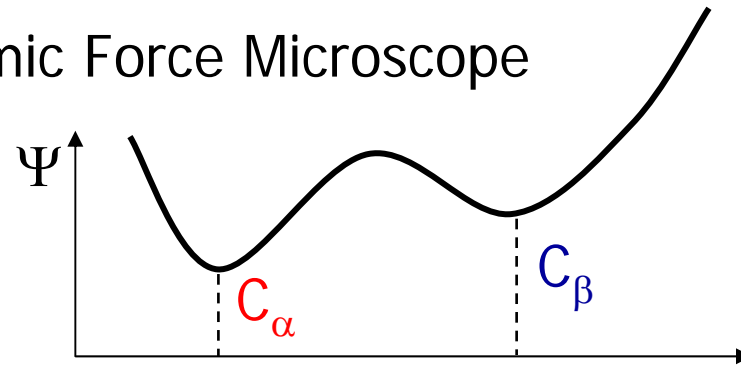
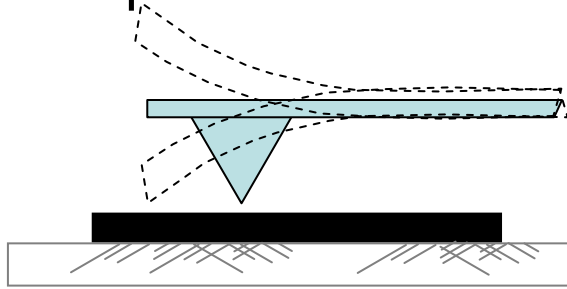

...asphalt under the Atomic Force Microscope

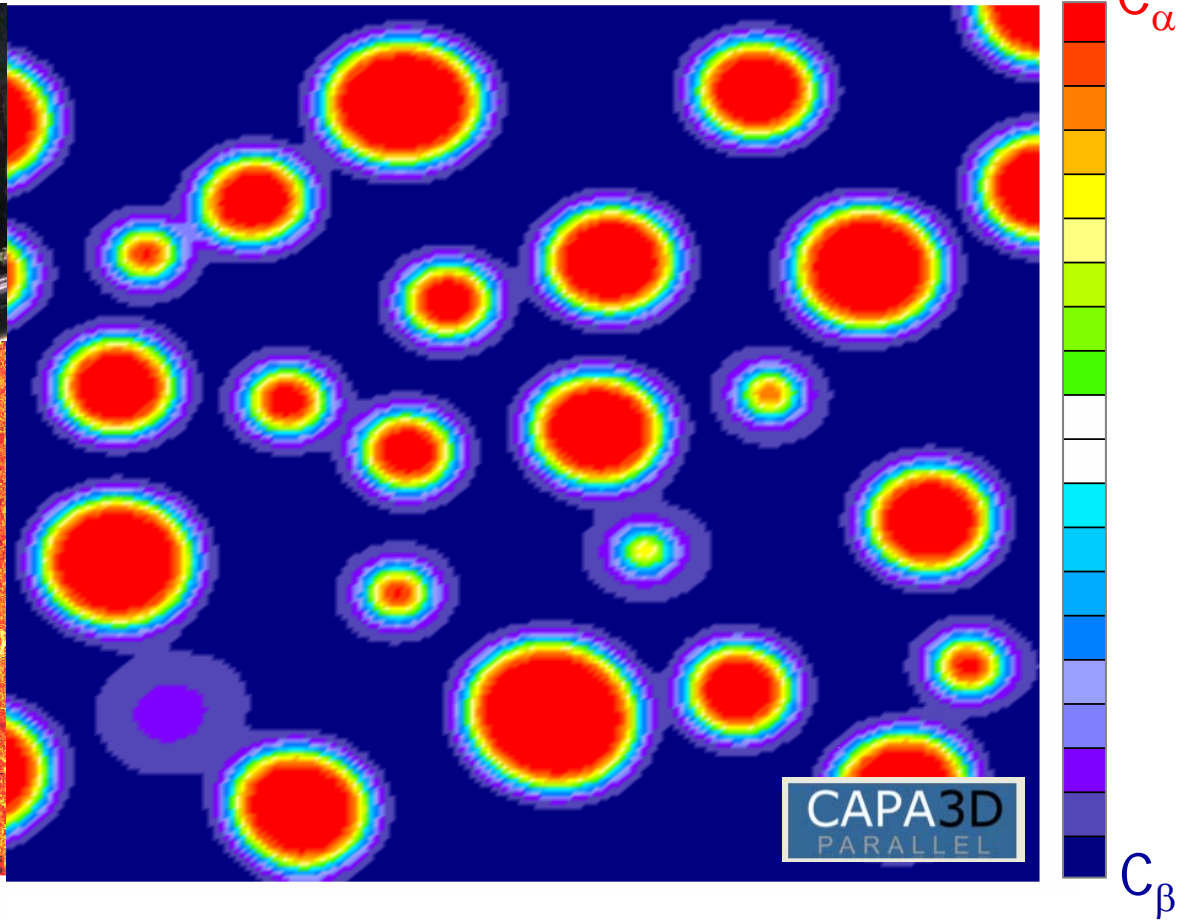
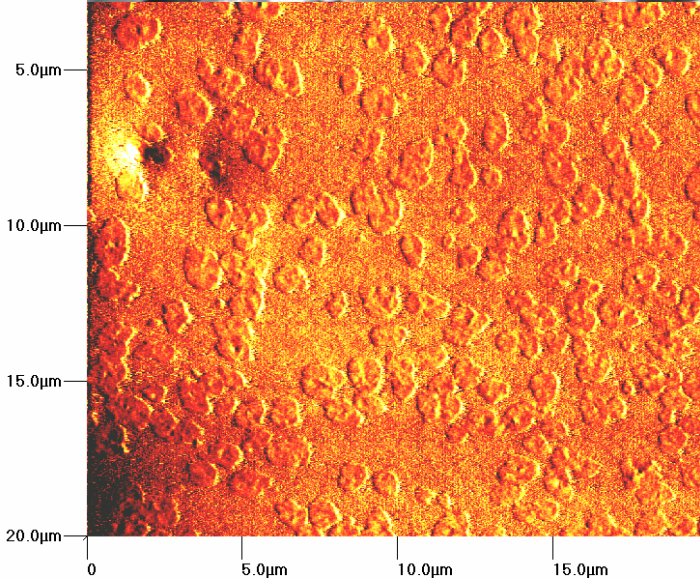
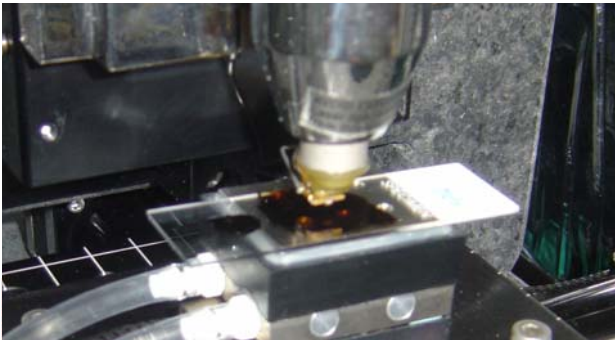
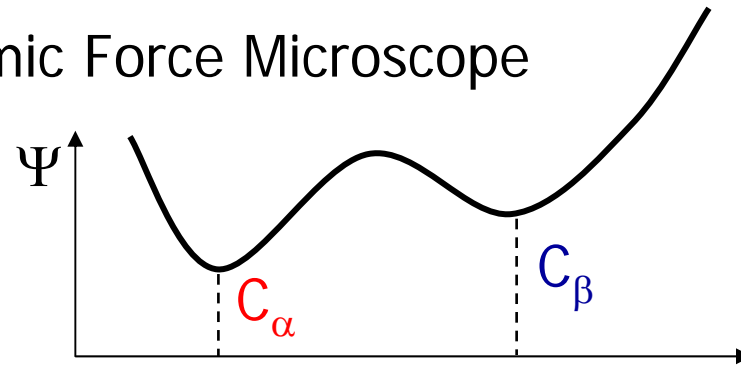
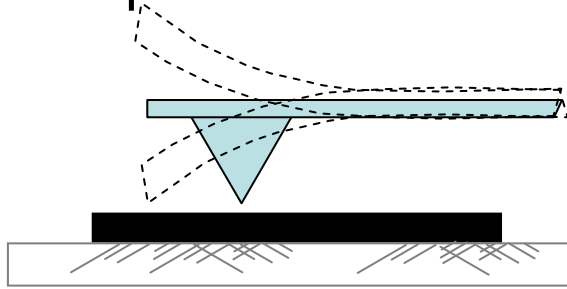

...asphalt under the Atomic Force Microscope

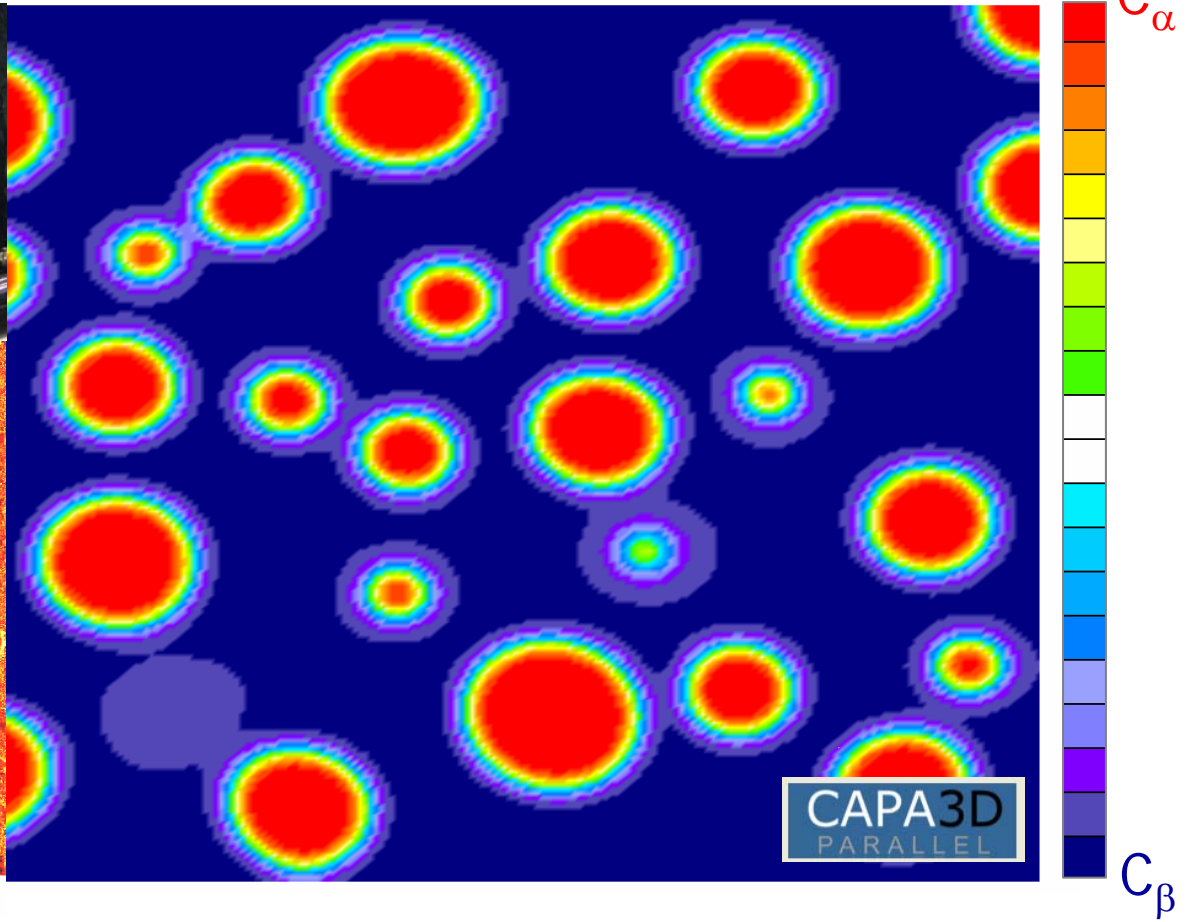
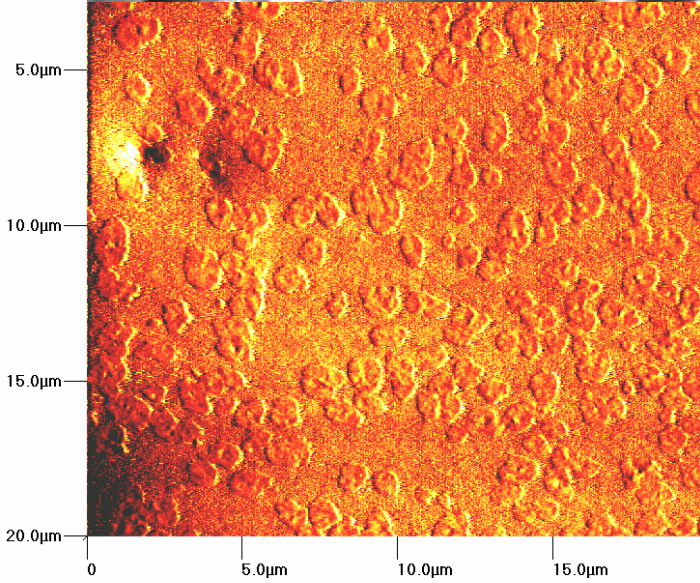
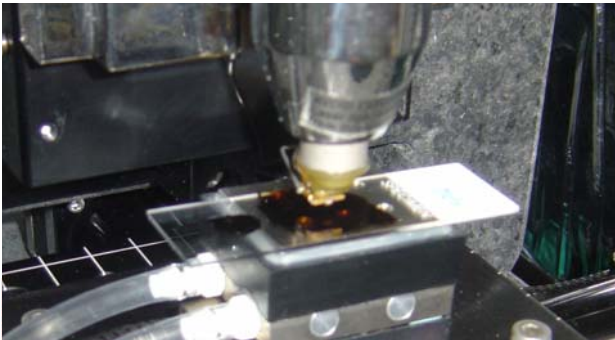
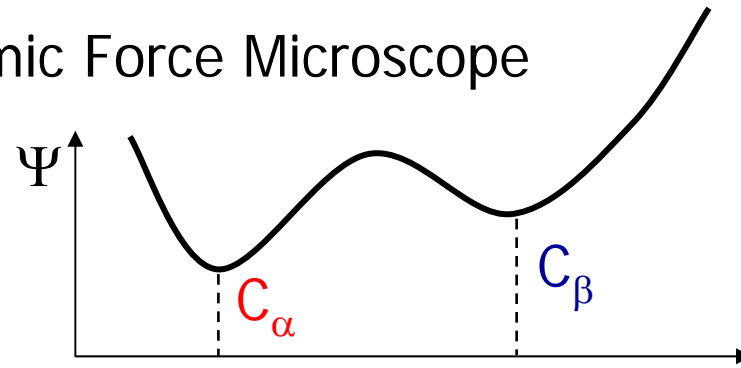
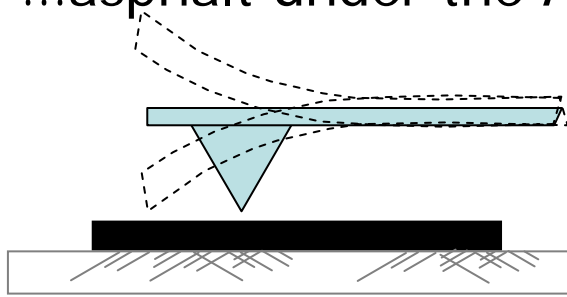

...asphalt under the Atomic Force Microscope

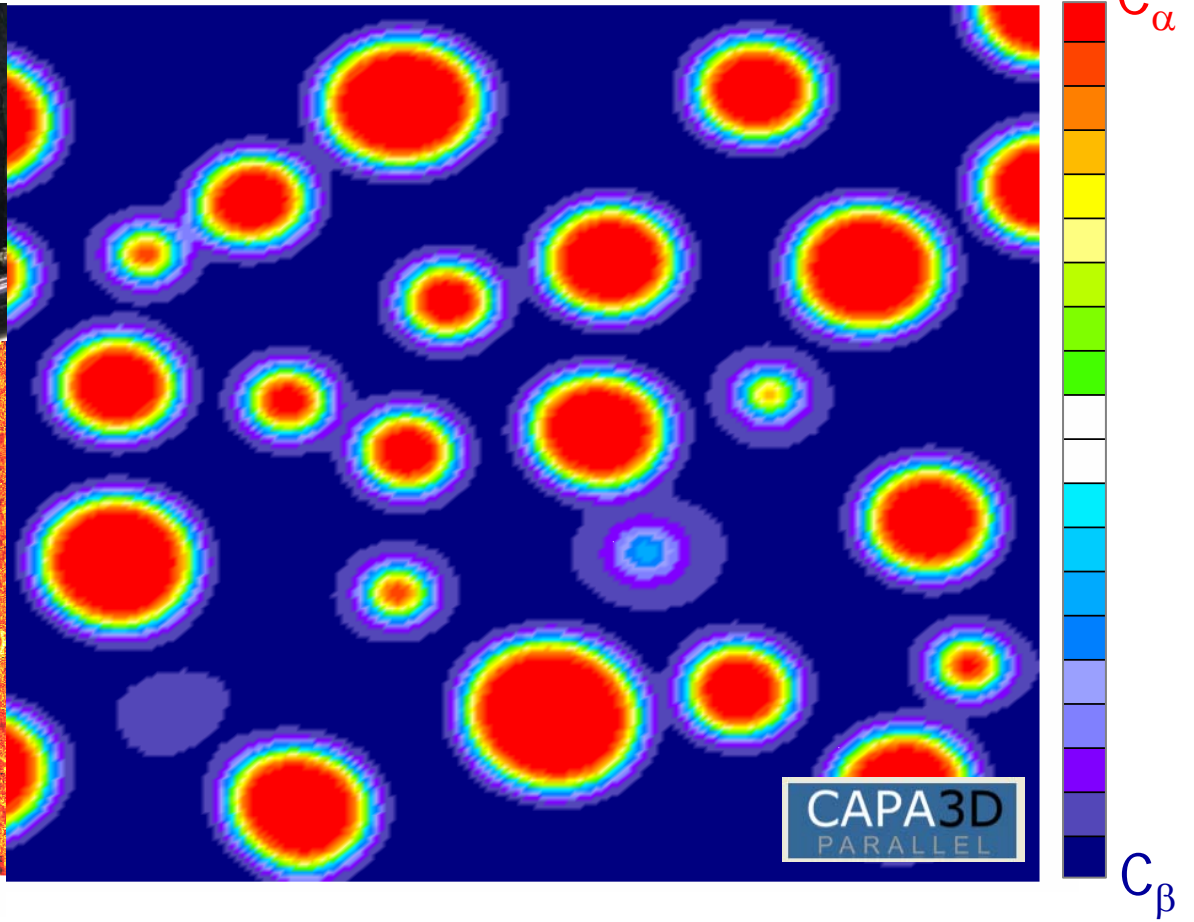
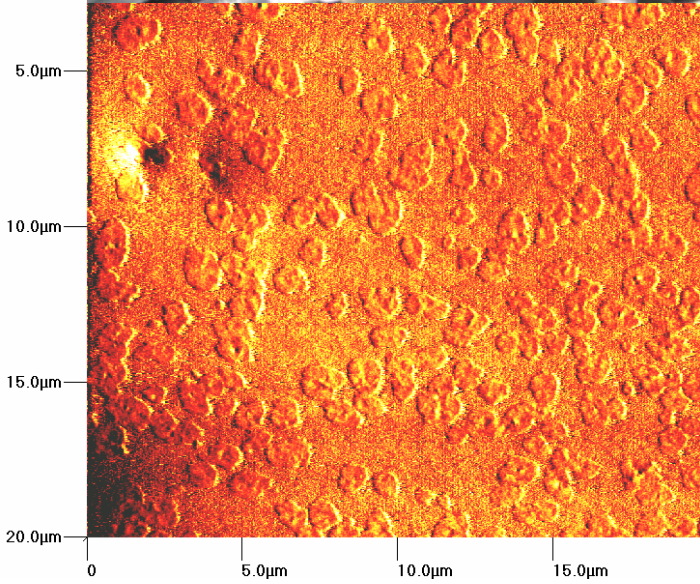
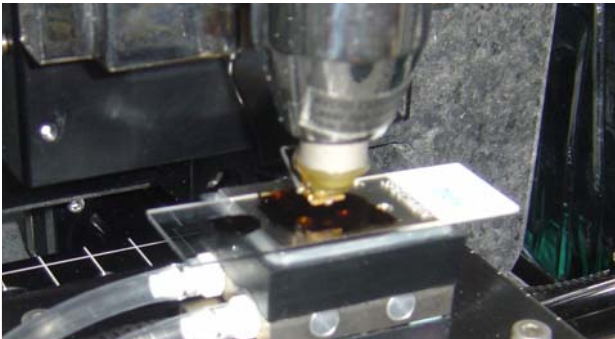
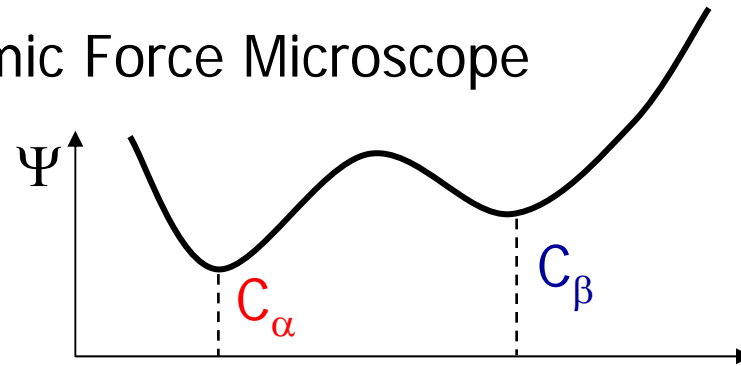
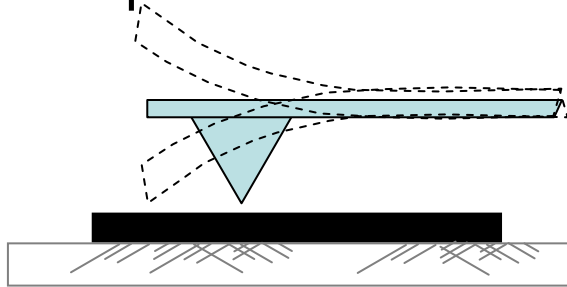

...asphalt under the Atomic Force Microscope

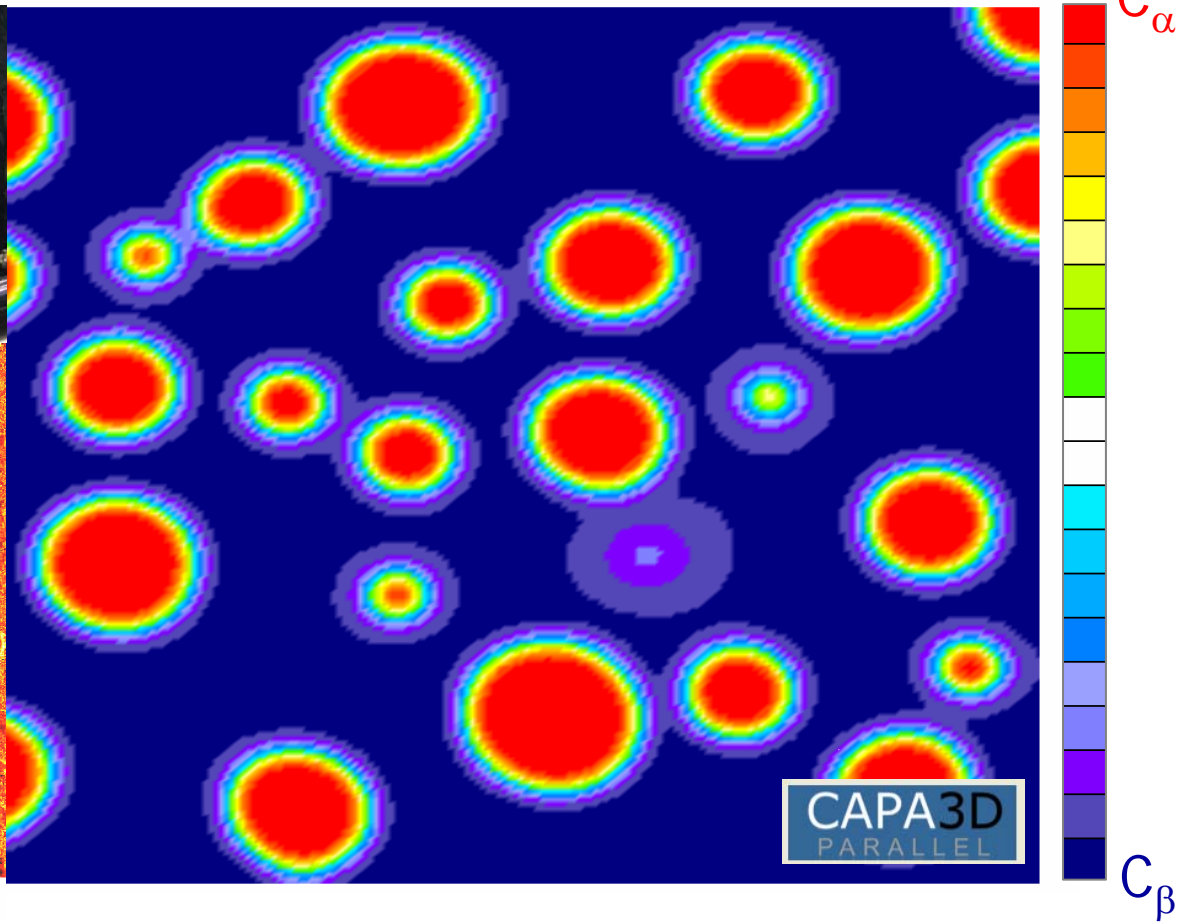
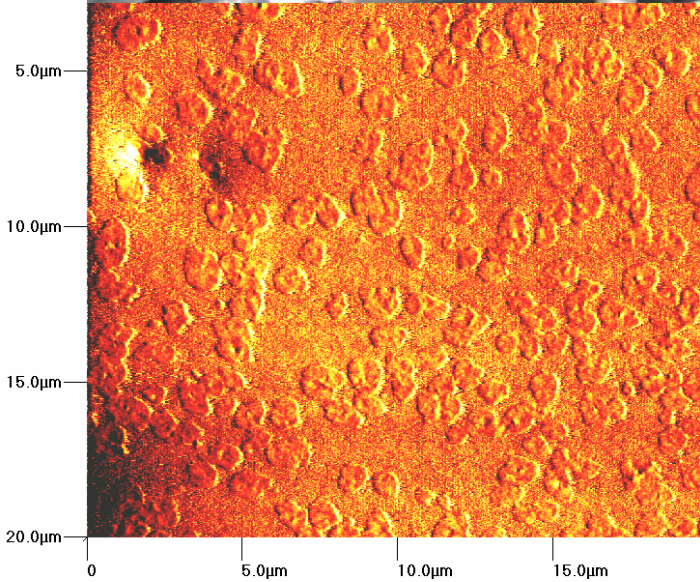
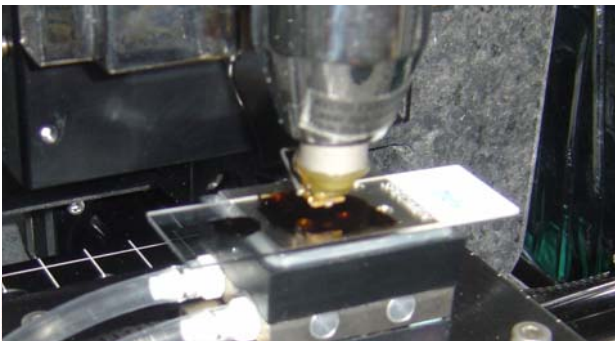
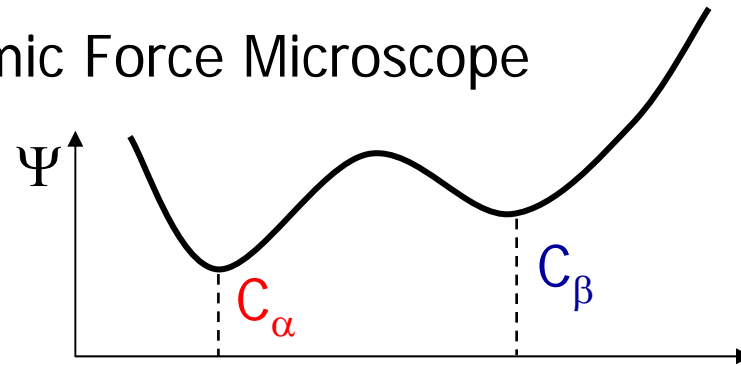
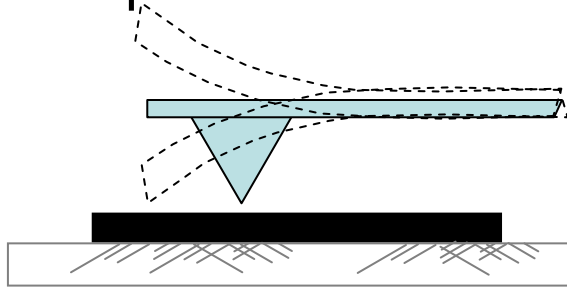

...asphalt under the Atomic Force Microscope

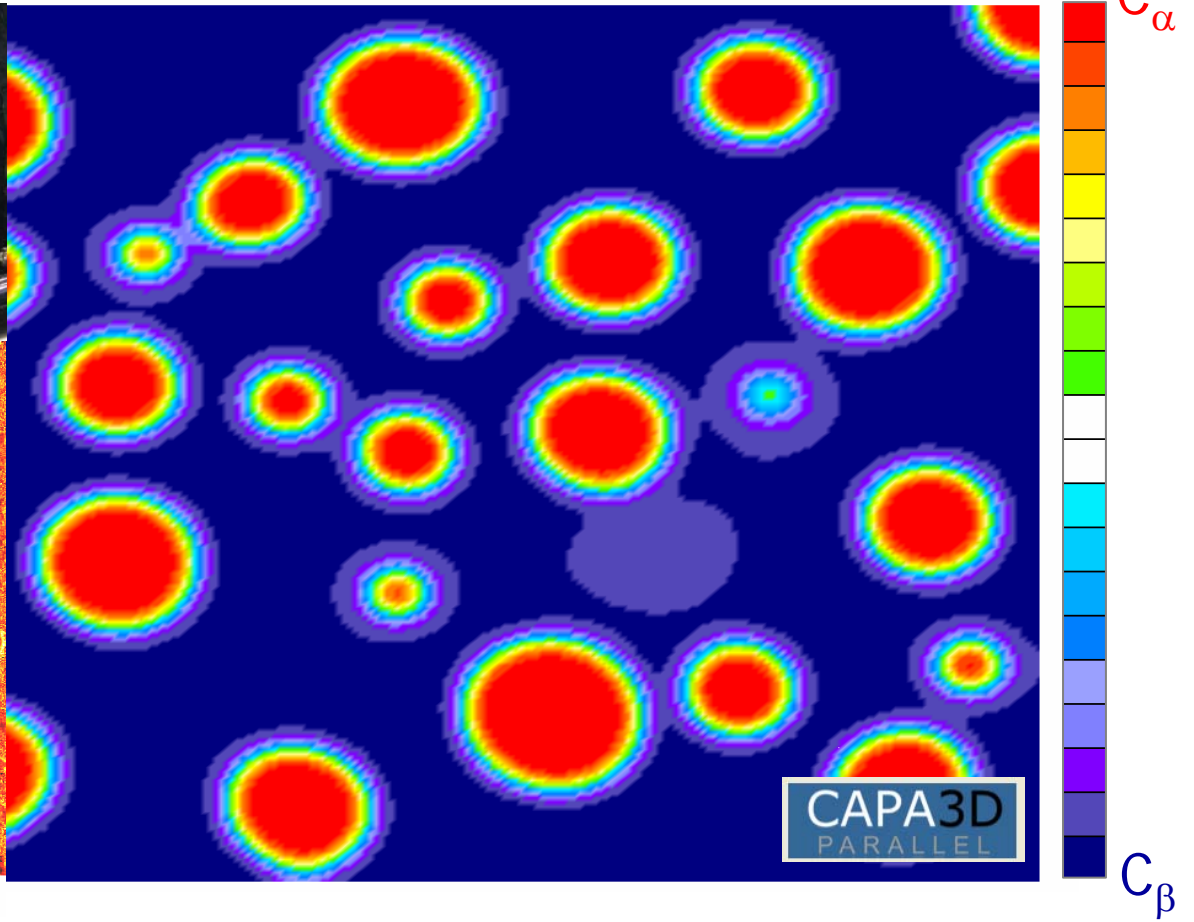
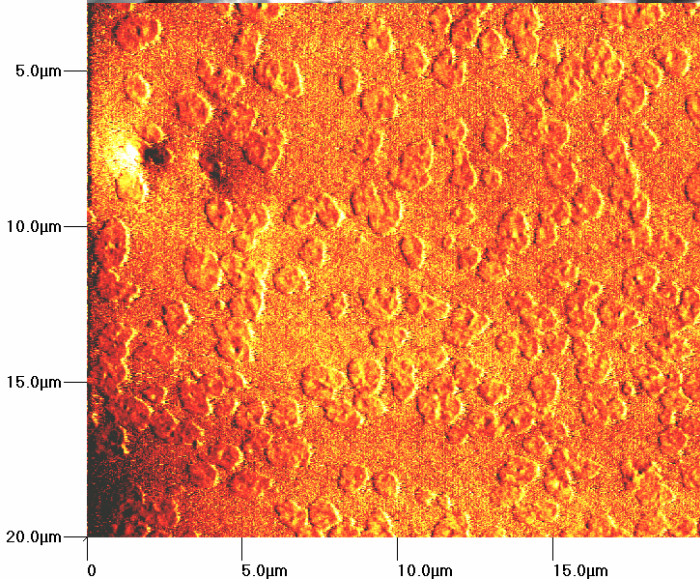
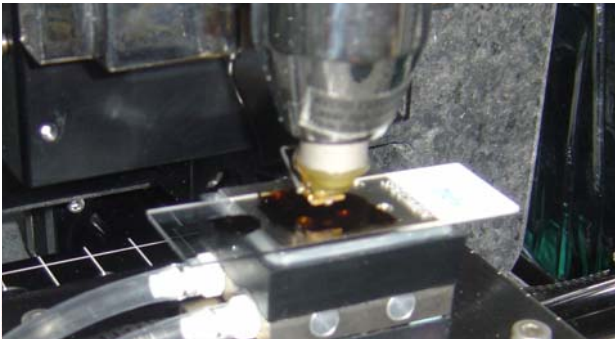
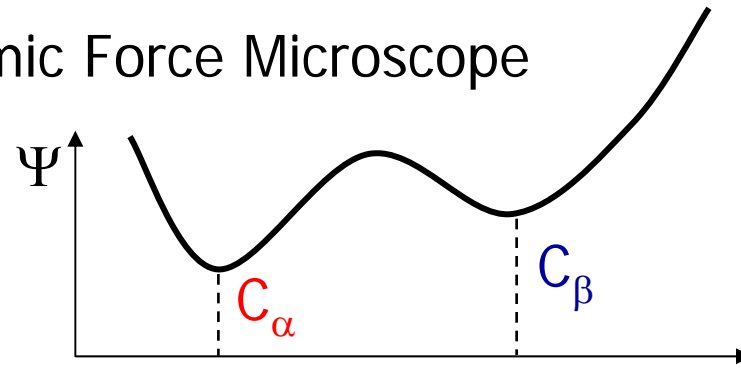
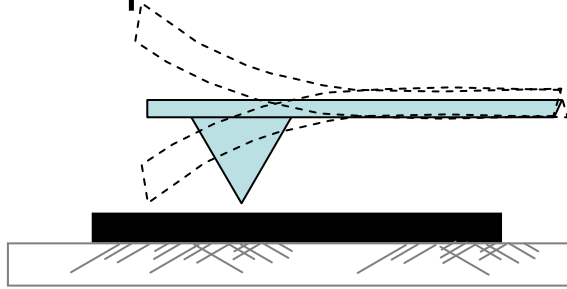

...asphalt under the Atomic Force Microscope

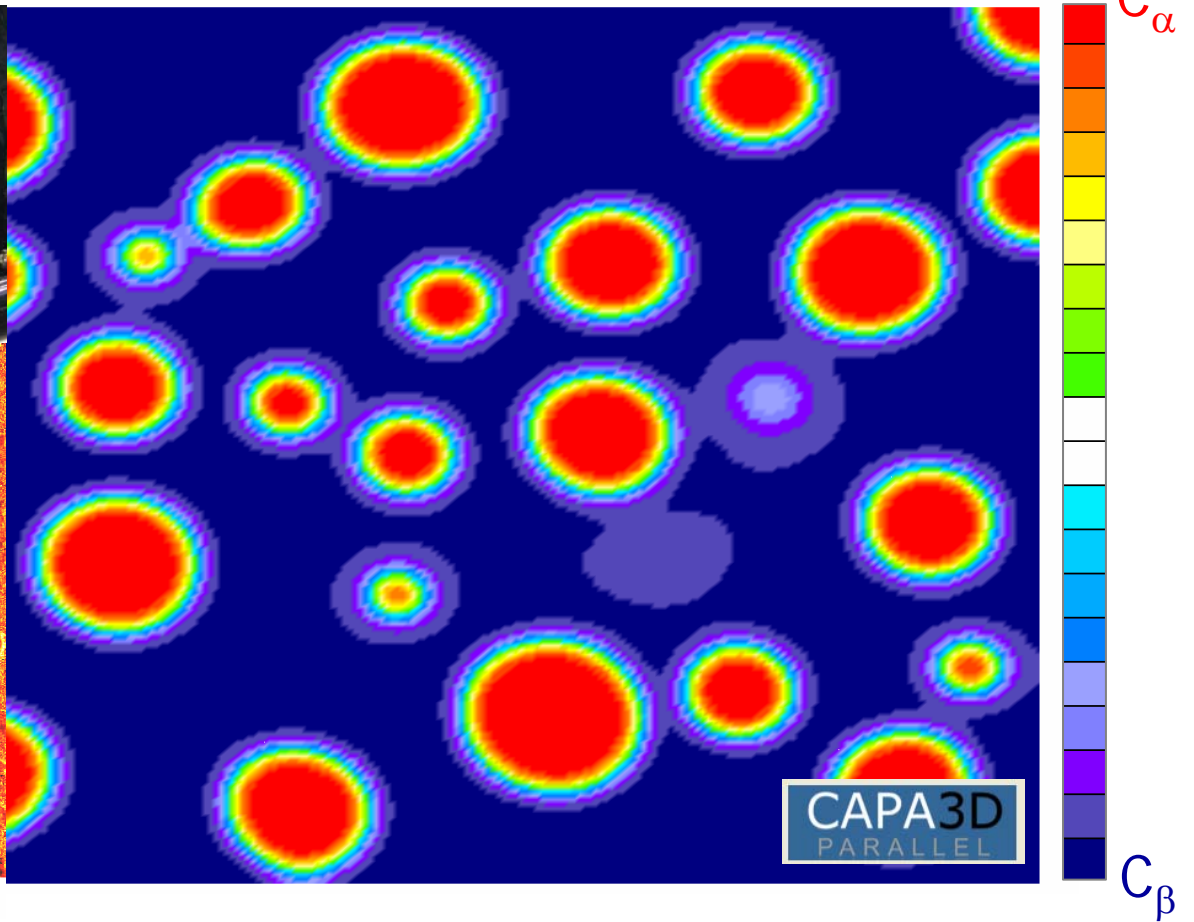
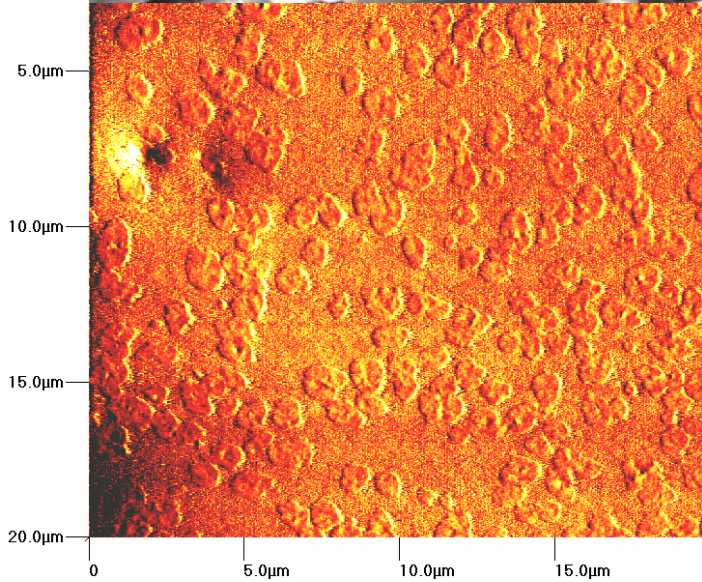
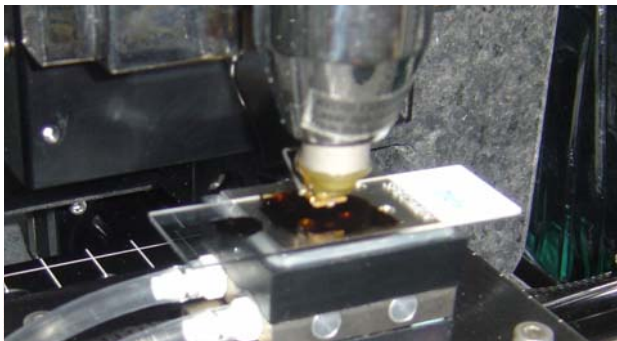
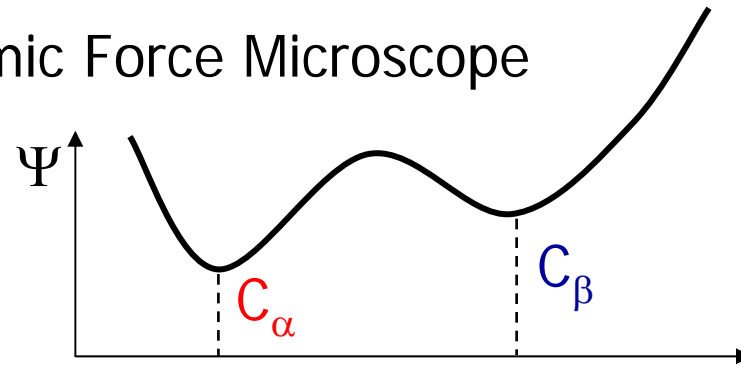
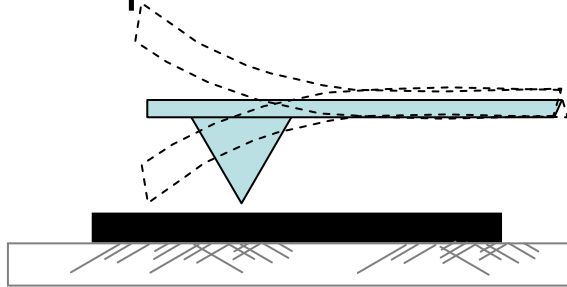

...asphalt under the Atomic Force Microscope

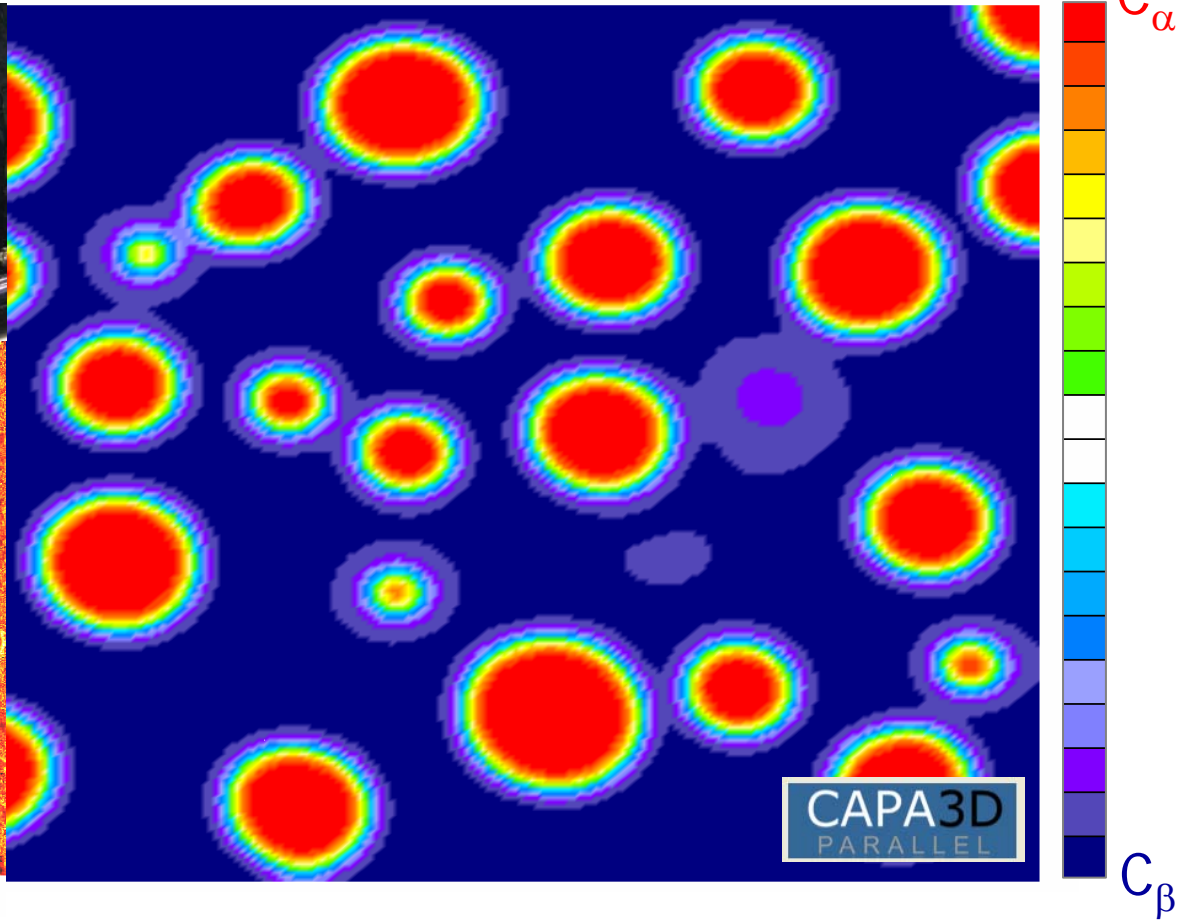
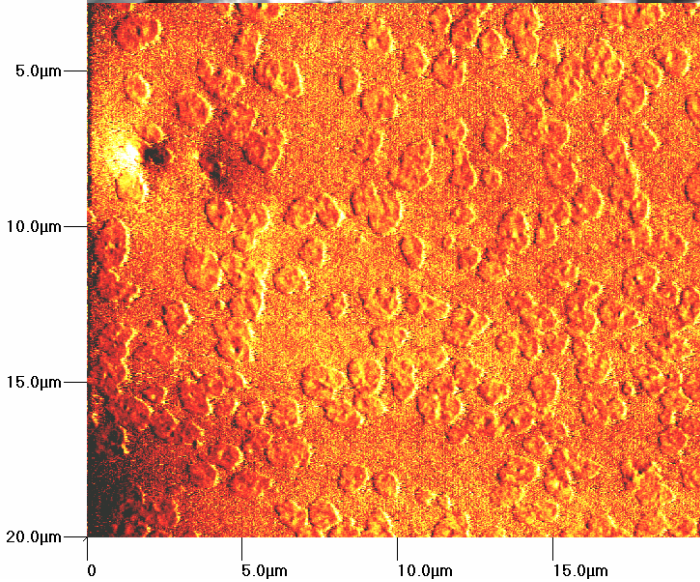
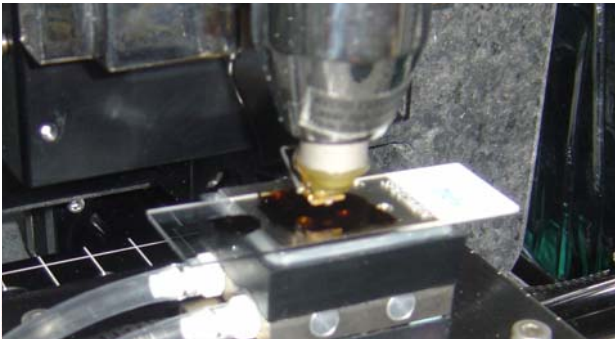
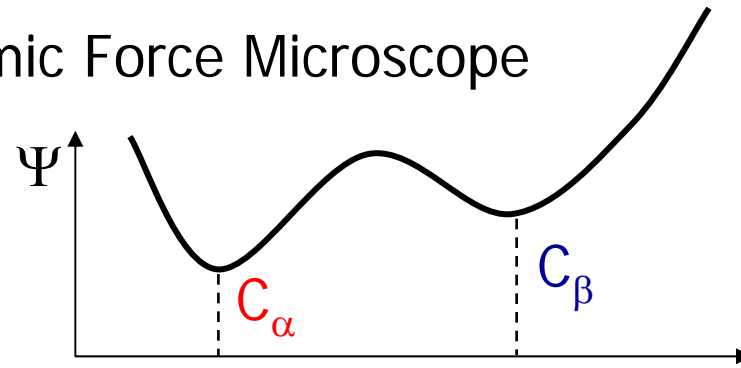
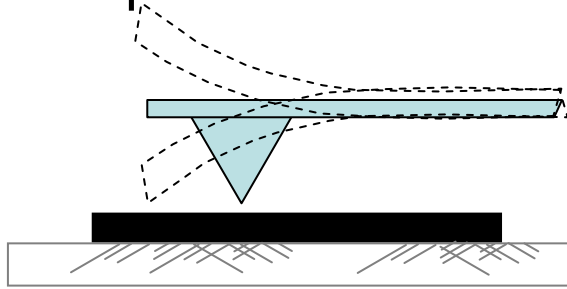

...asphalt under the Atomic Force Microscope

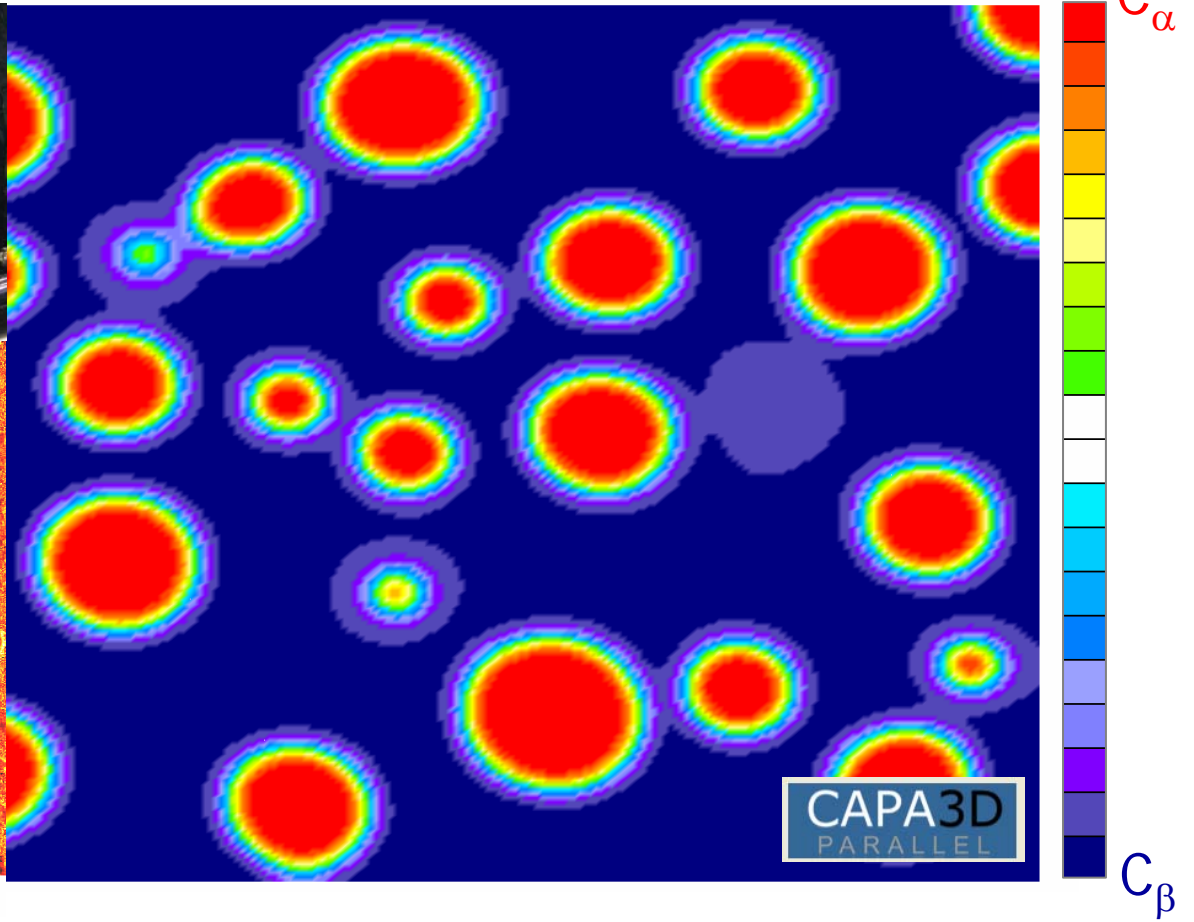
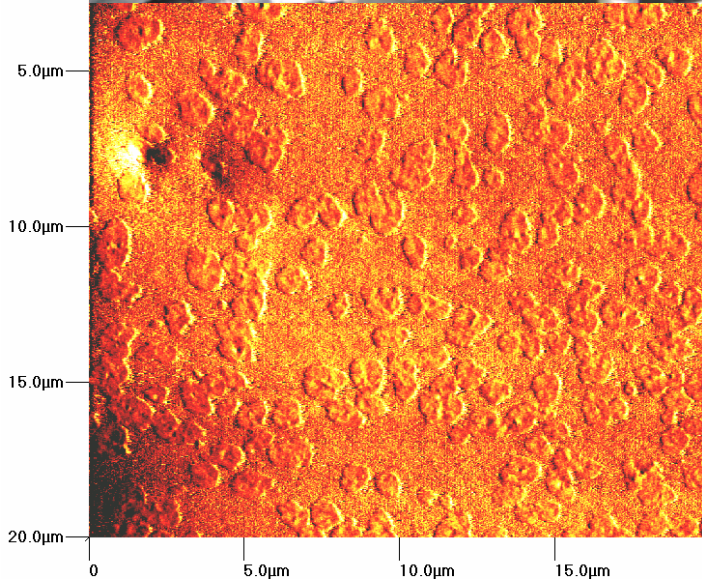
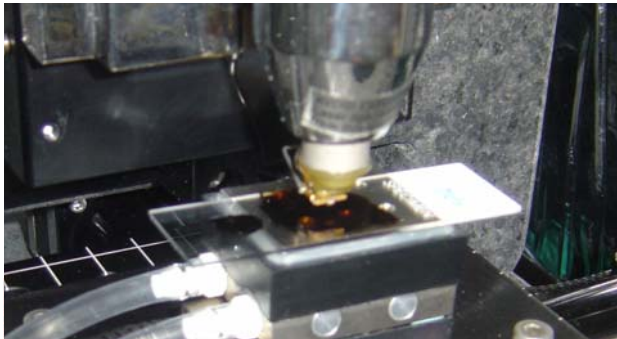
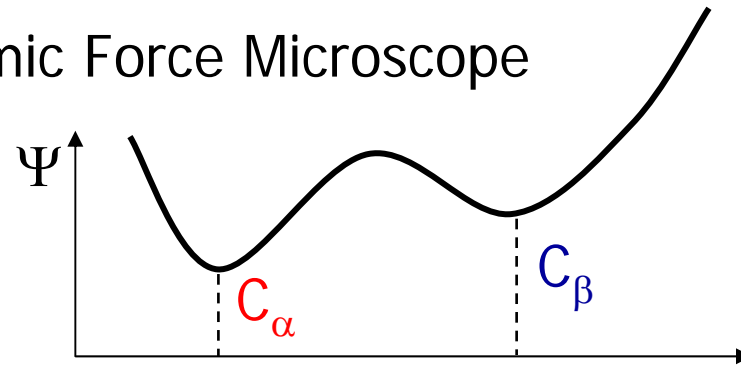
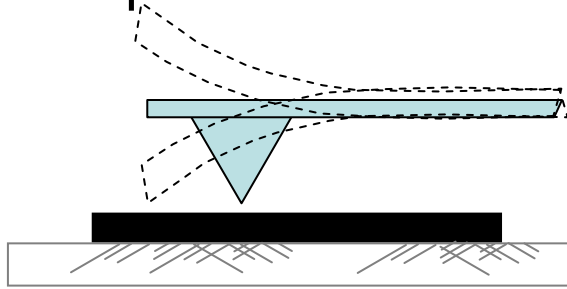

...asphalt under the Atomic Force Microscope

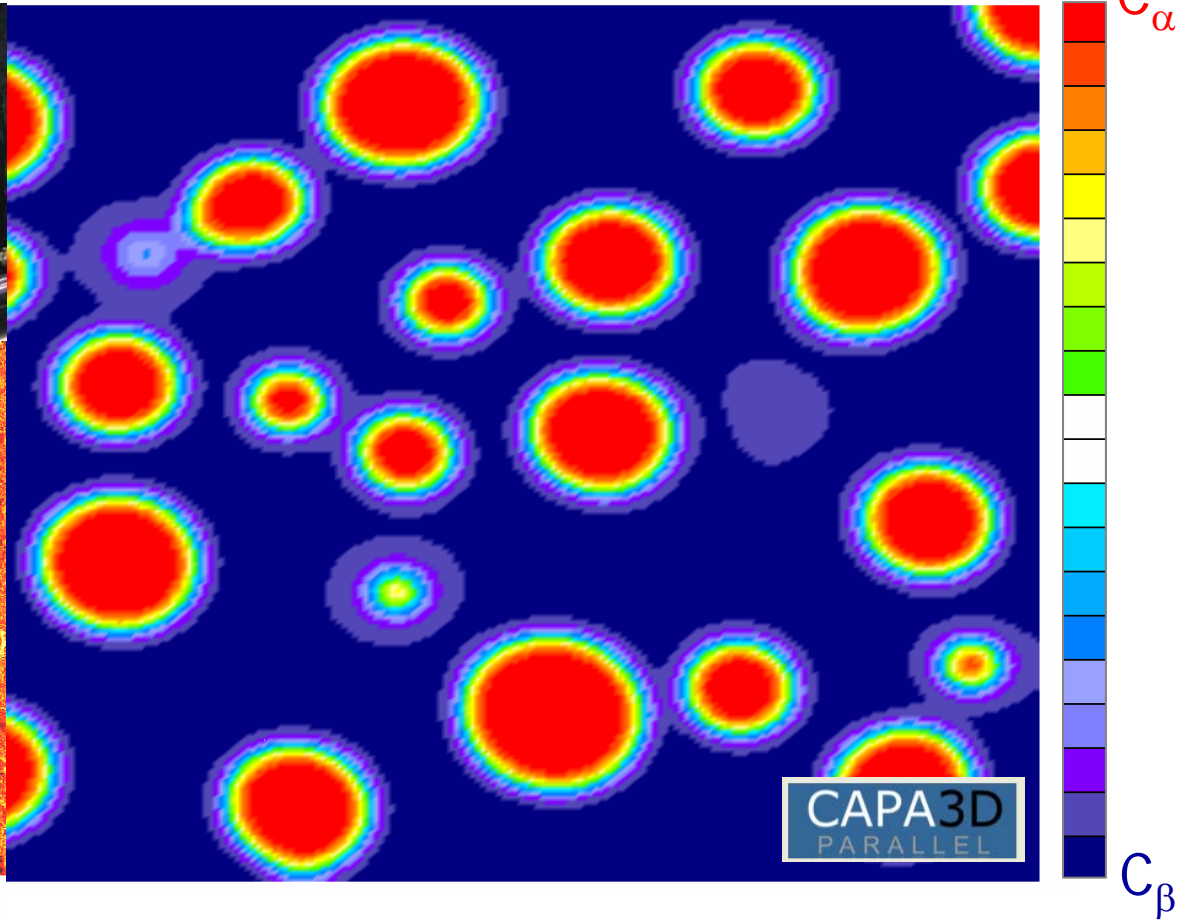
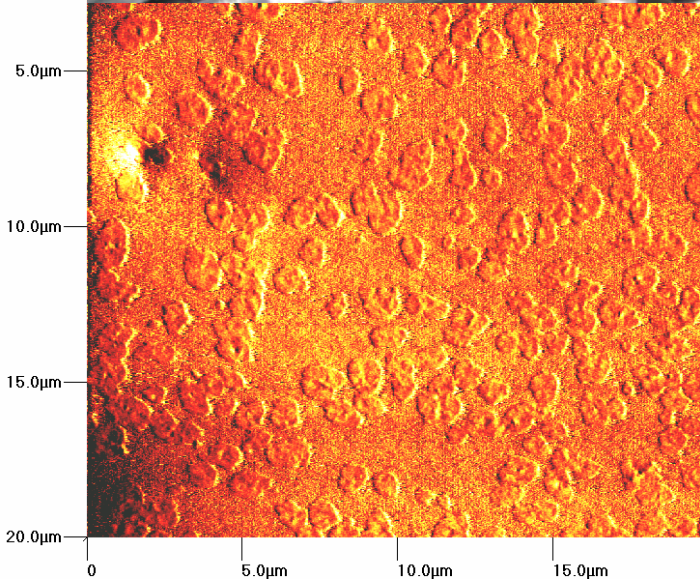
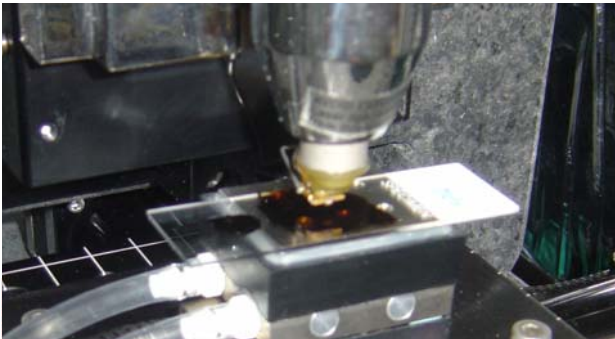
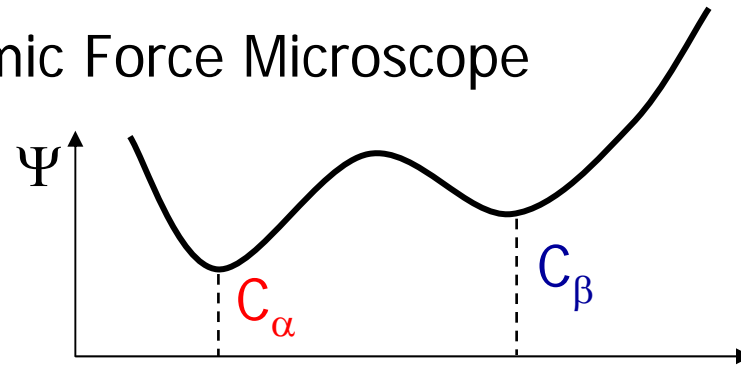
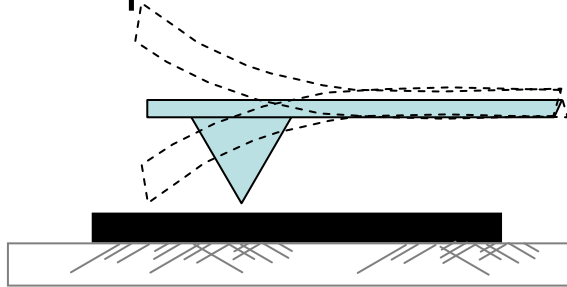

...asphalt under the Atomic Force Microscope

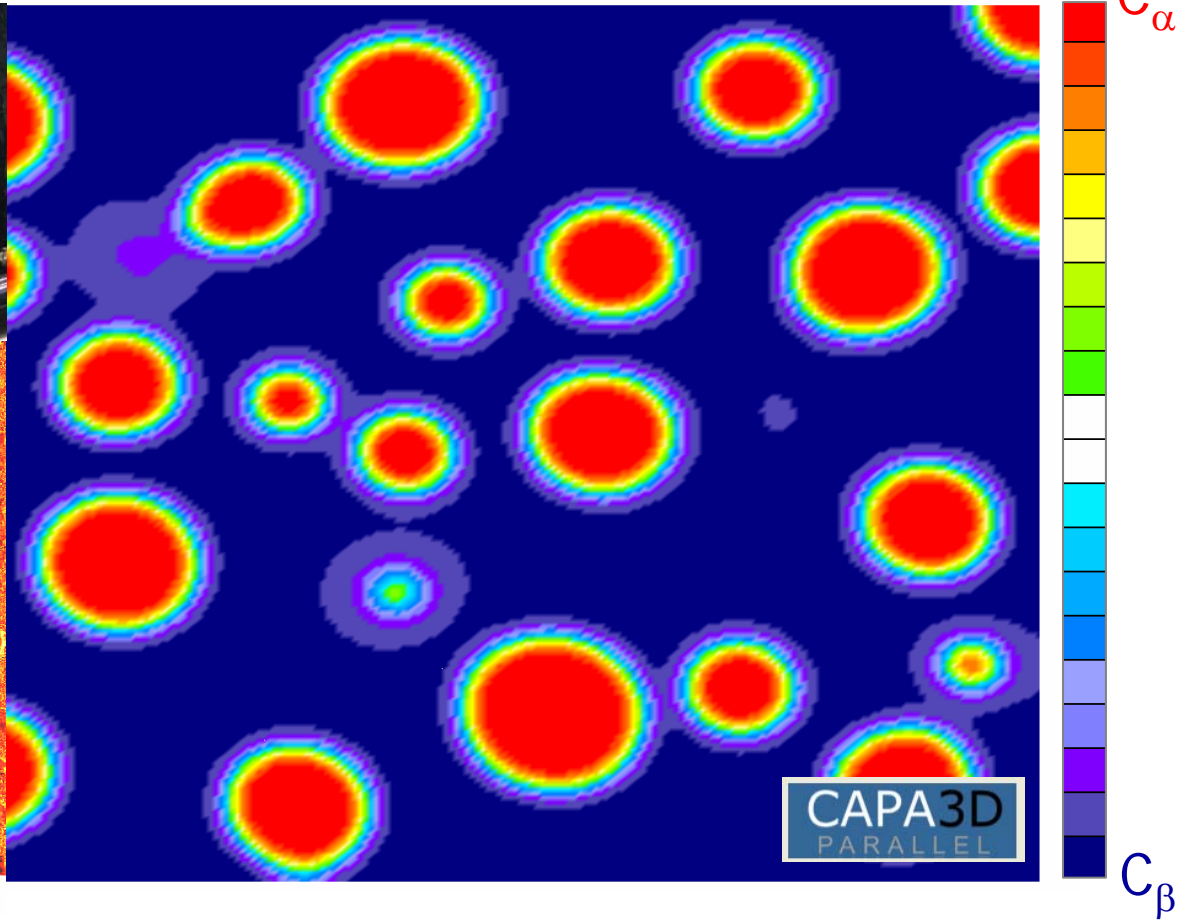
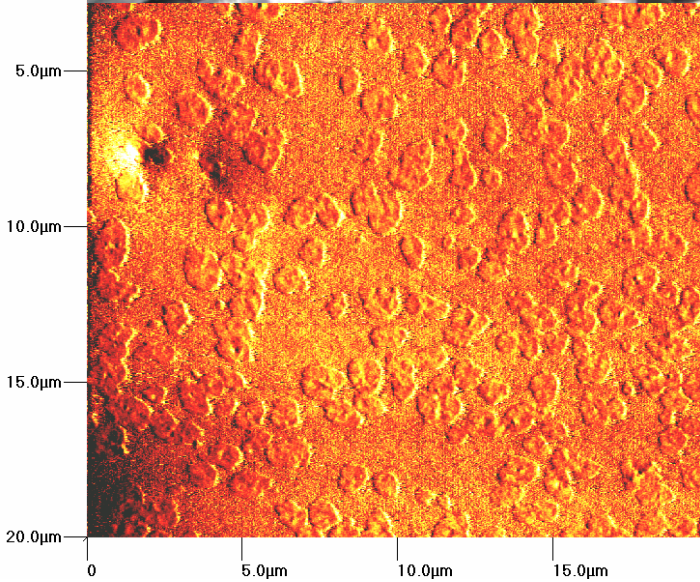
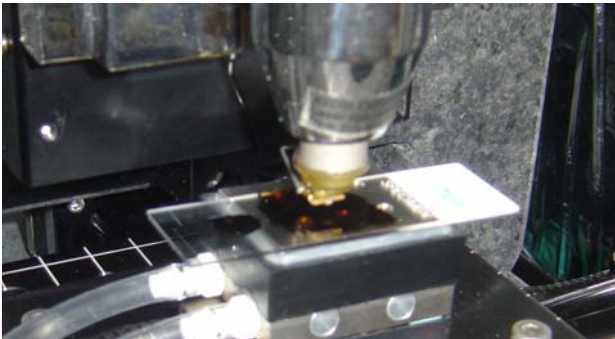
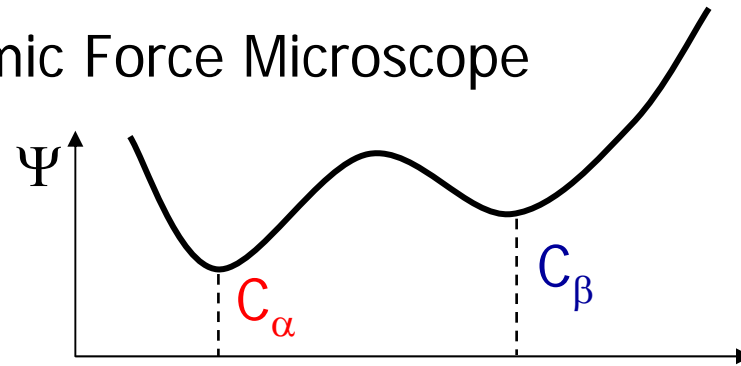
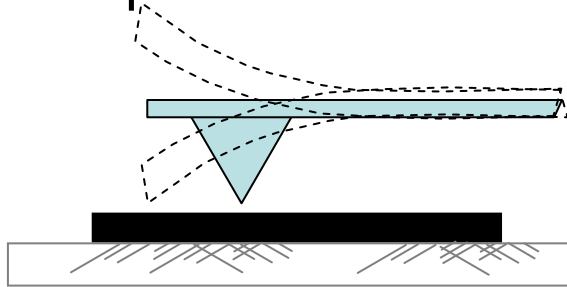

...asphalt under the Atomic Force Microscope

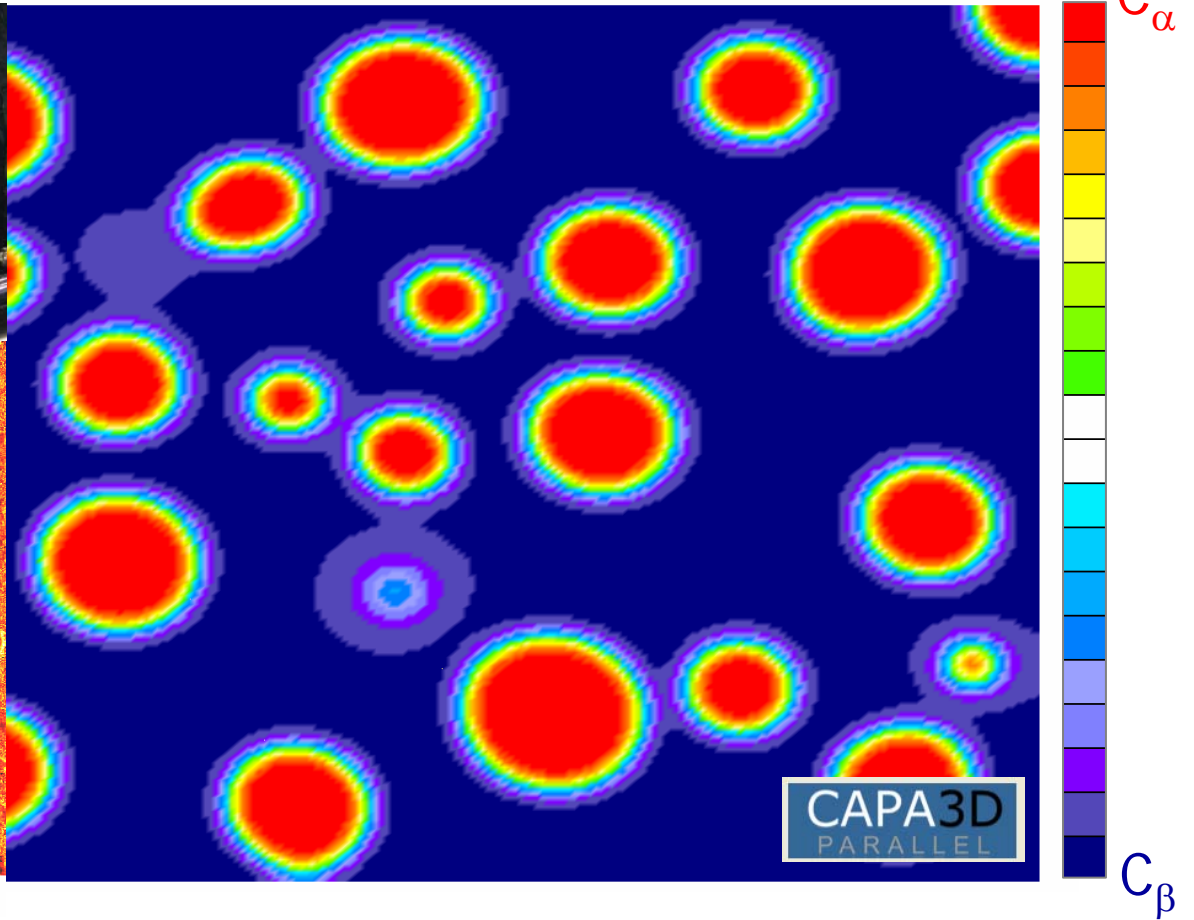
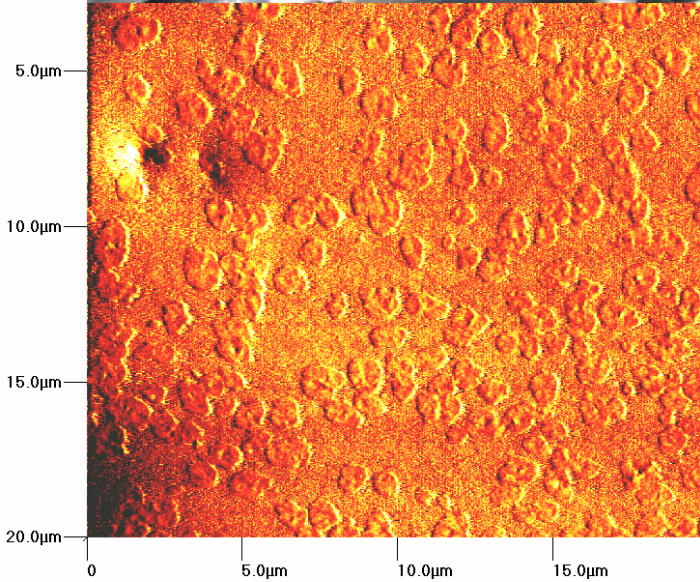
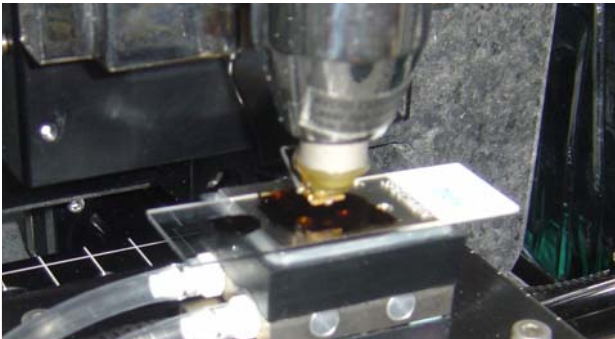
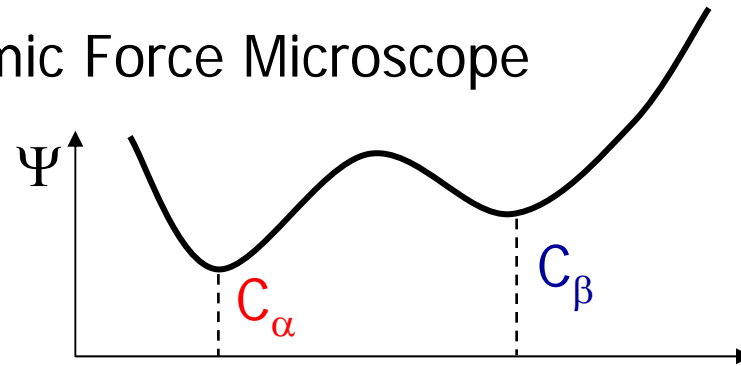
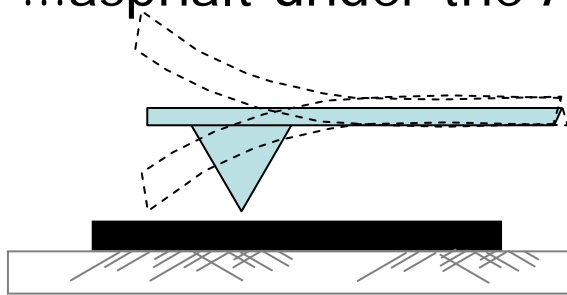

...asphalt under the Atomic Force Microscope

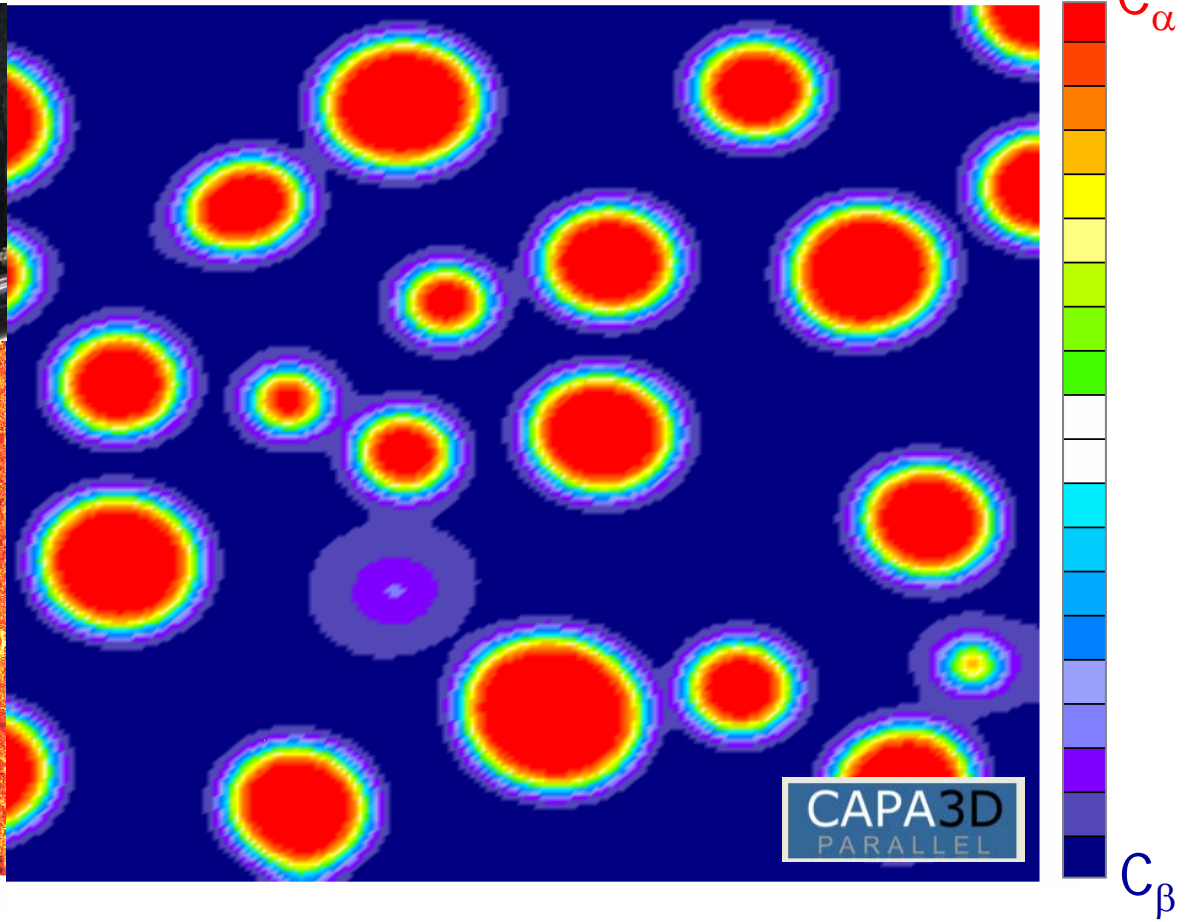
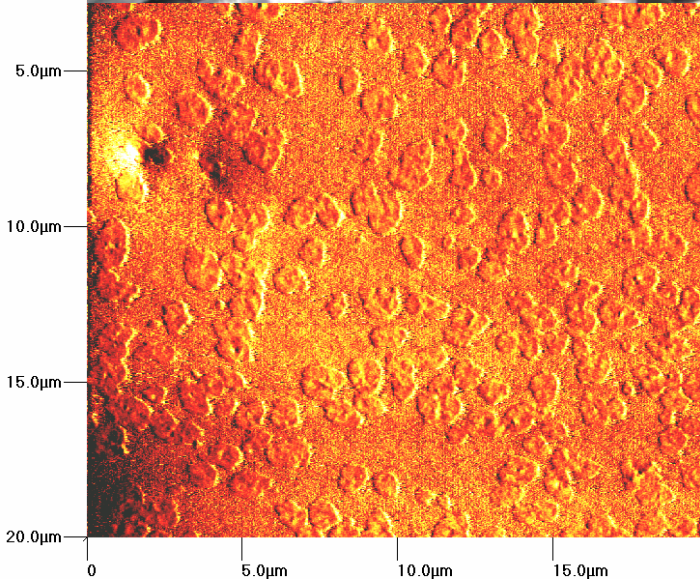
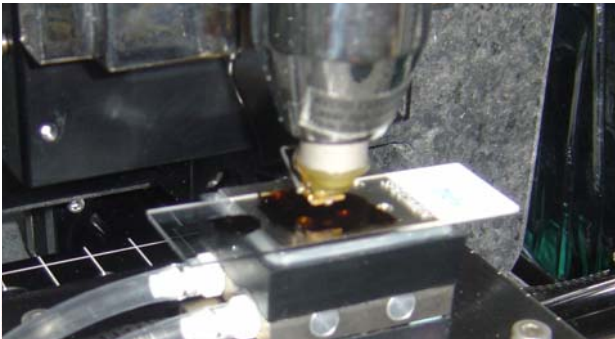
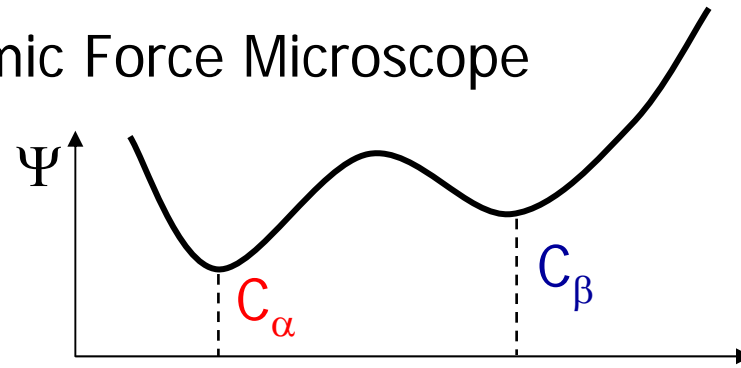
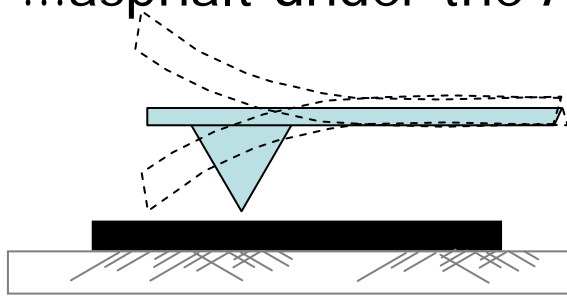

...asphalt under the Atomic Force Microscope

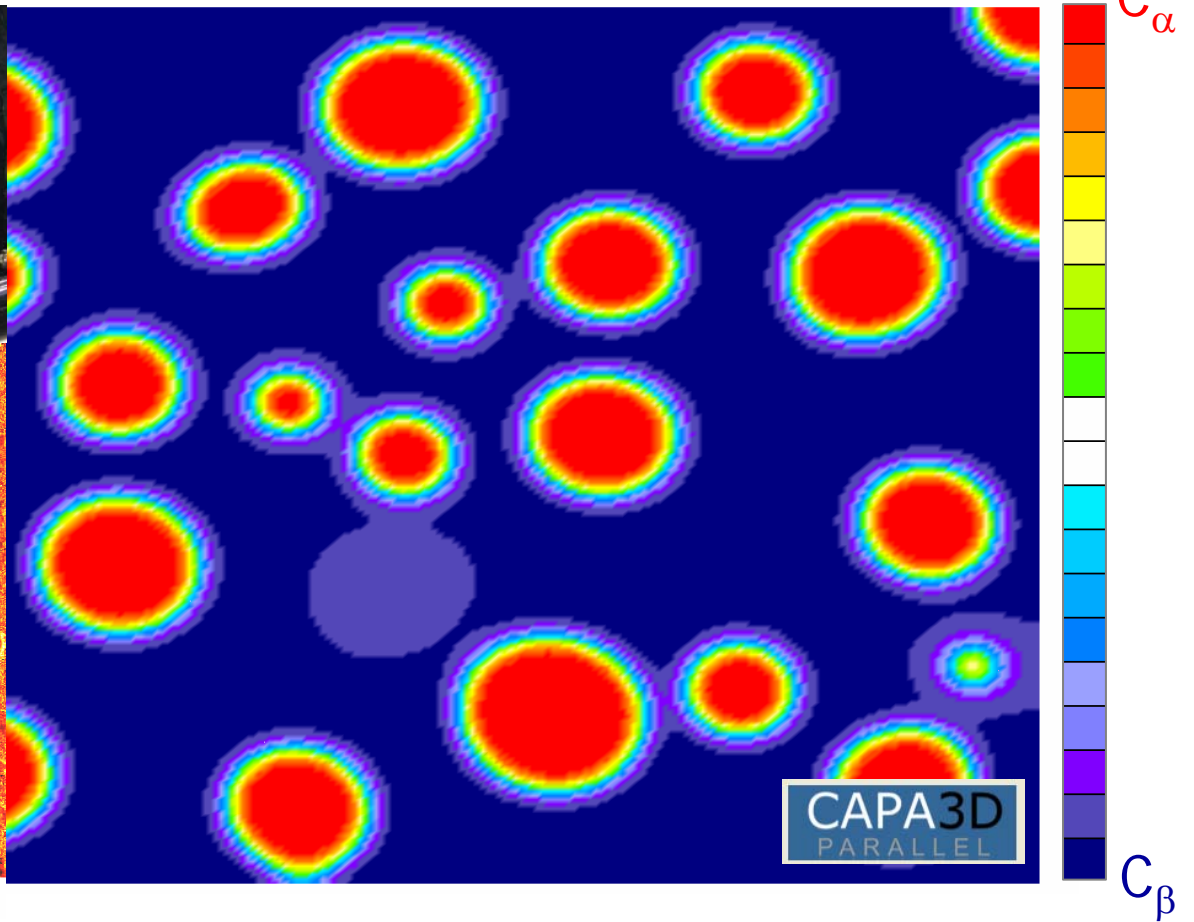
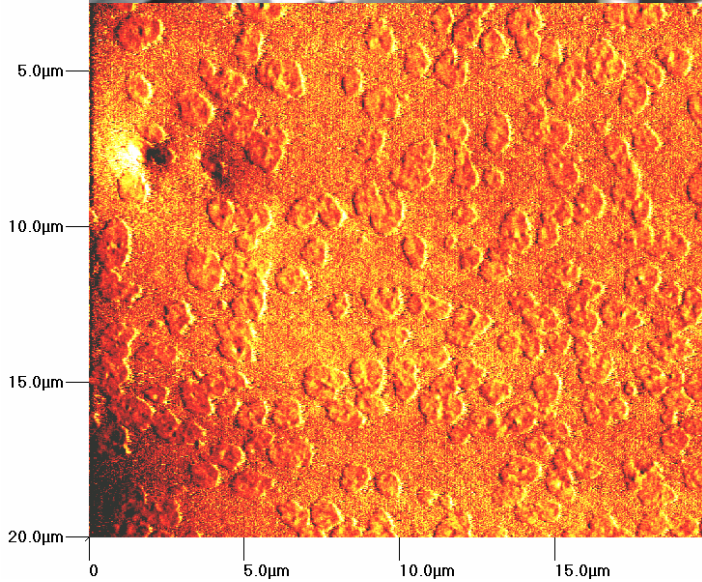
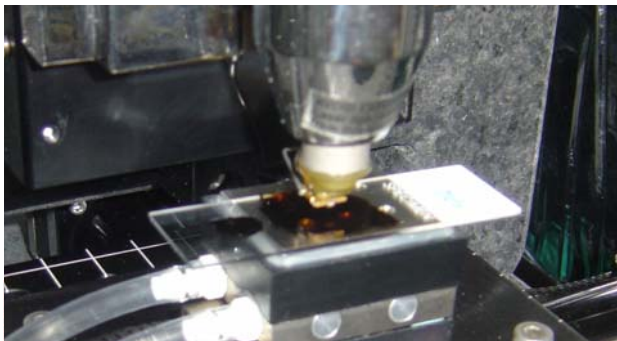
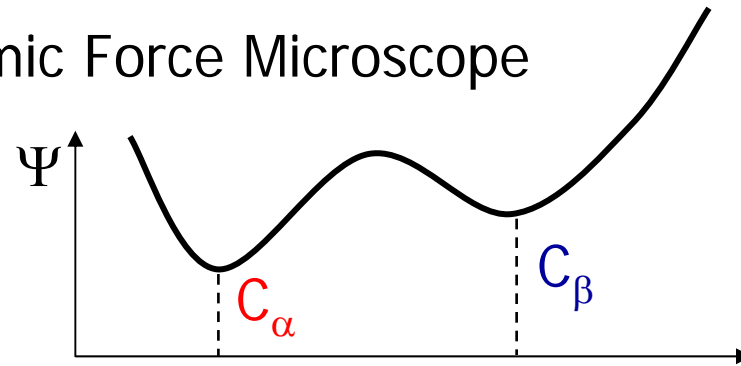
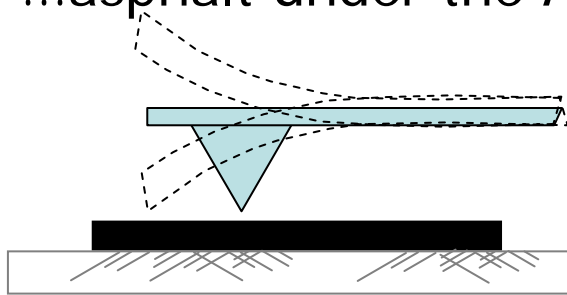

...asphalt under the Atomic Force Microscope

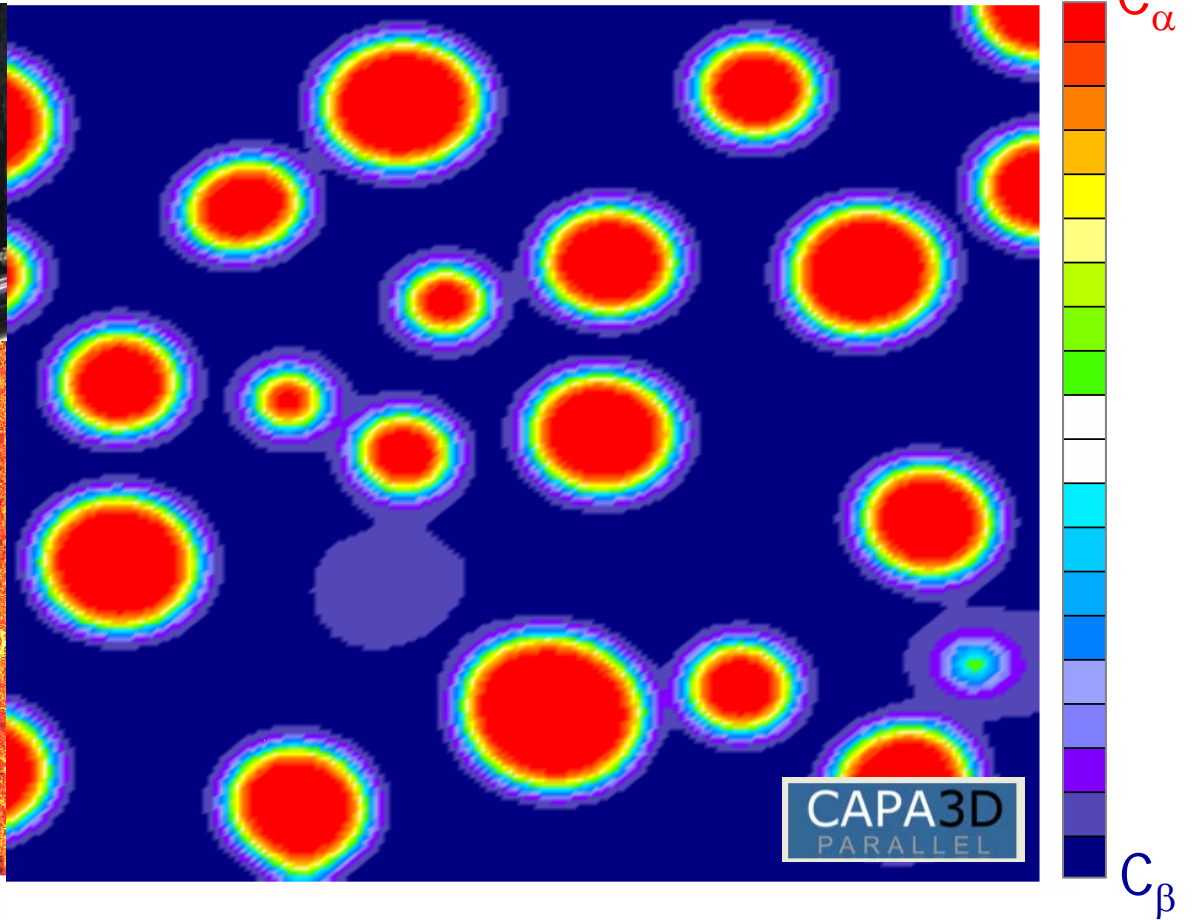
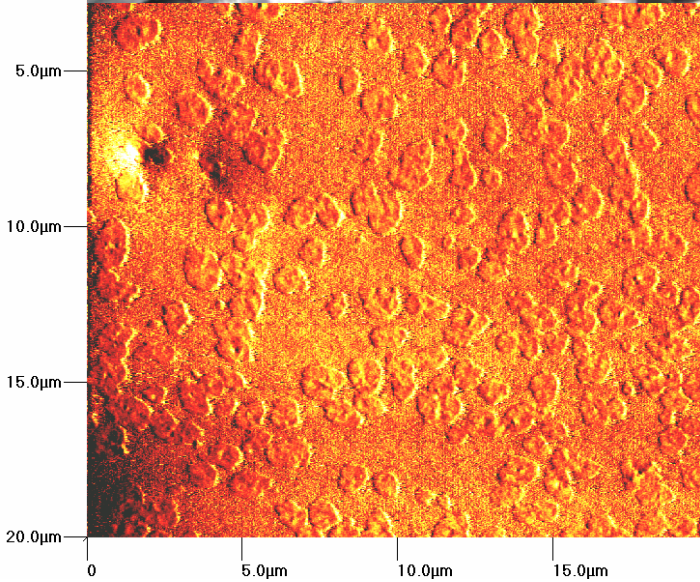
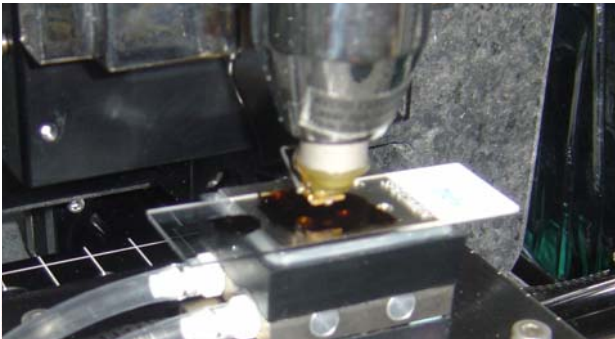
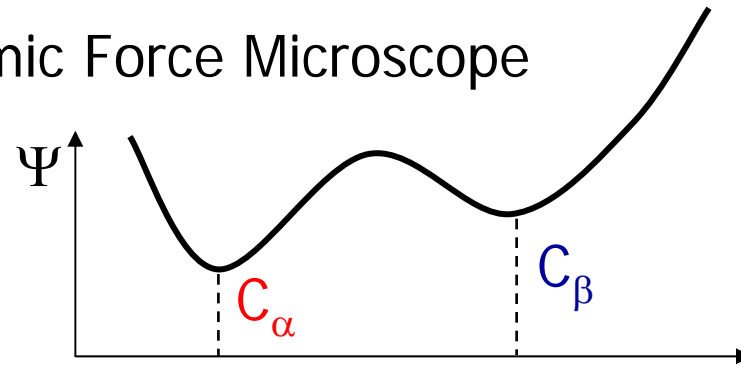
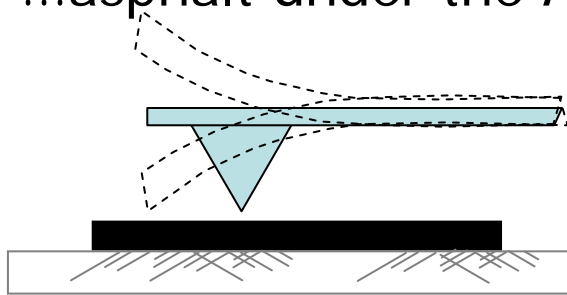

...asphalt under the Atomic Force Microscope

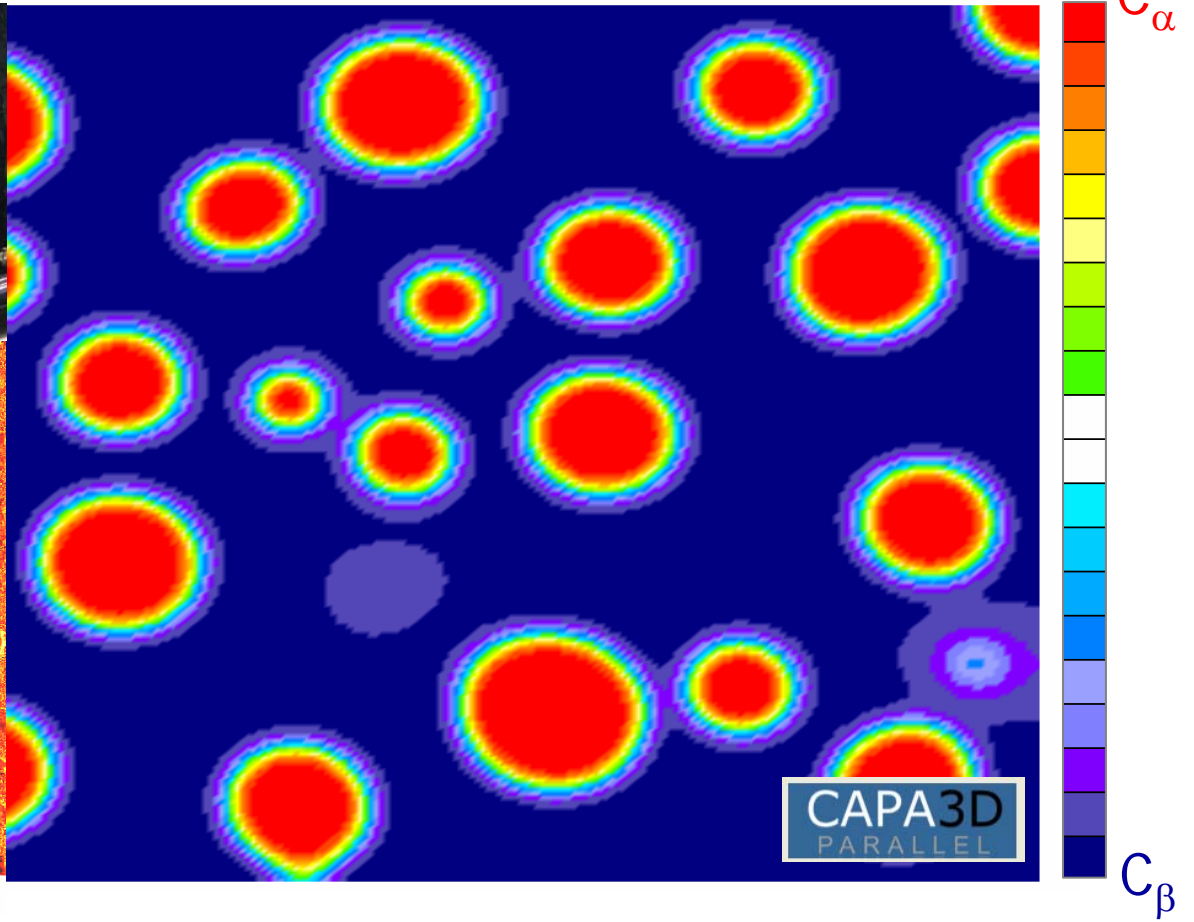
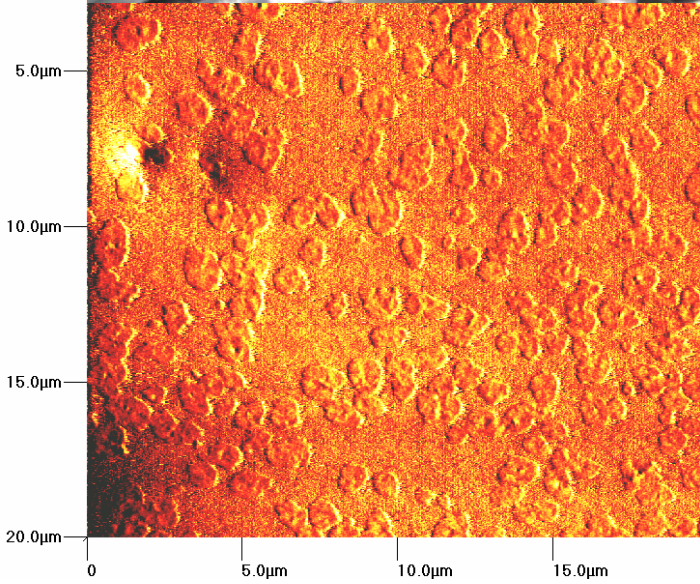
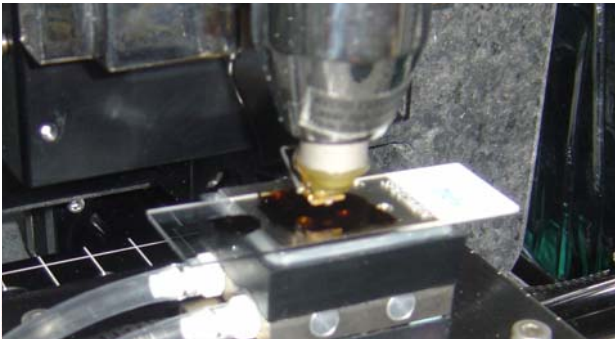
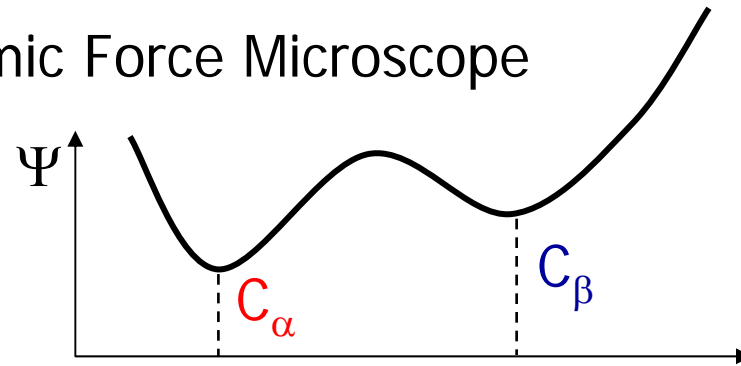
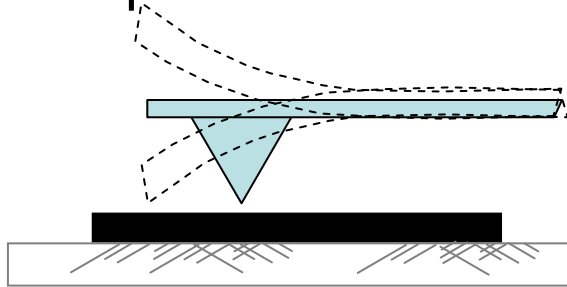

...asphalt under the Atomic Force Microscope

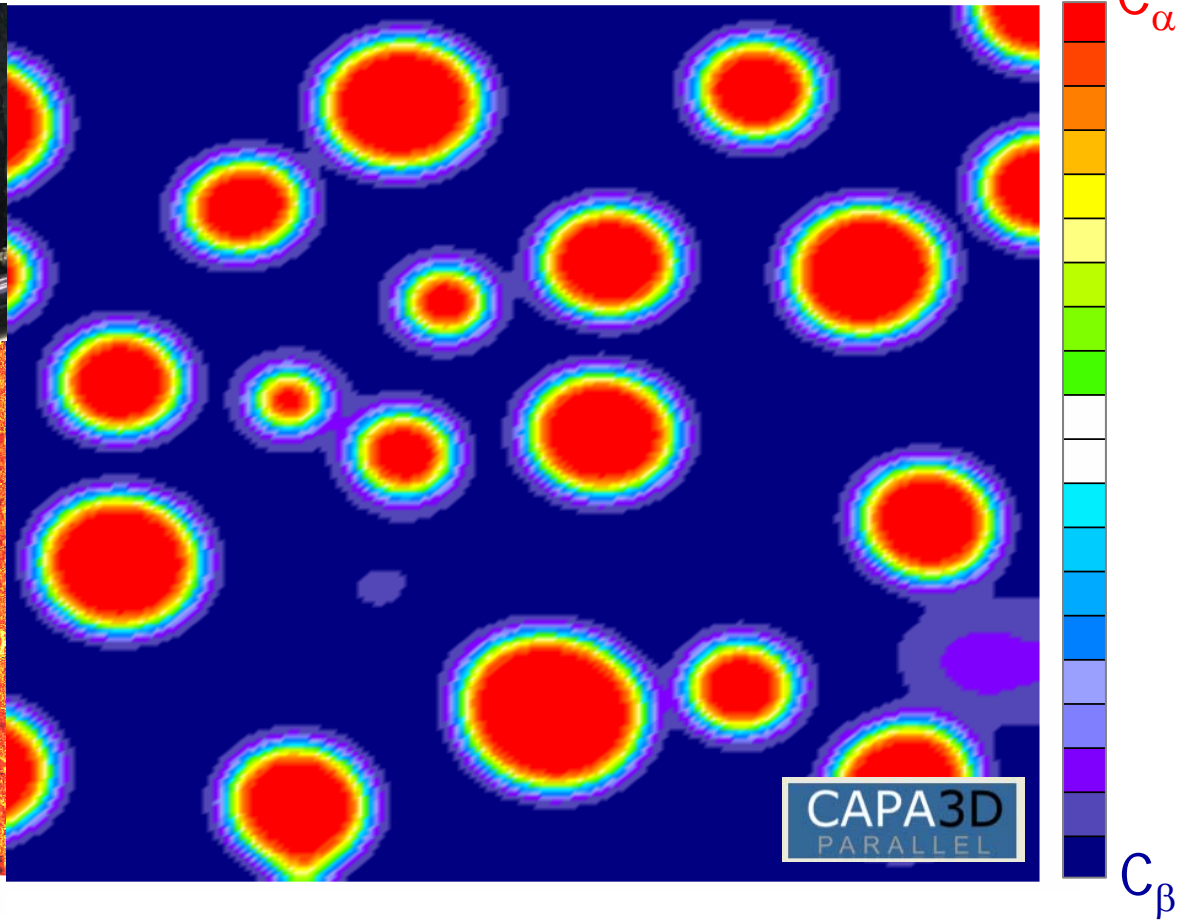
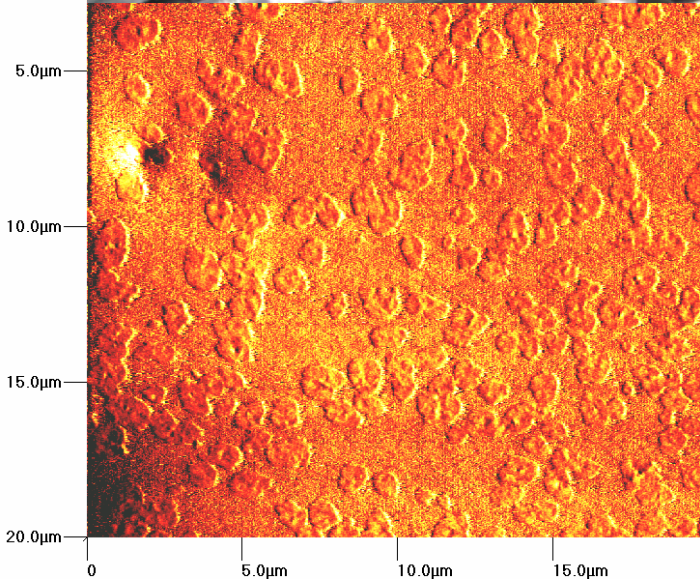
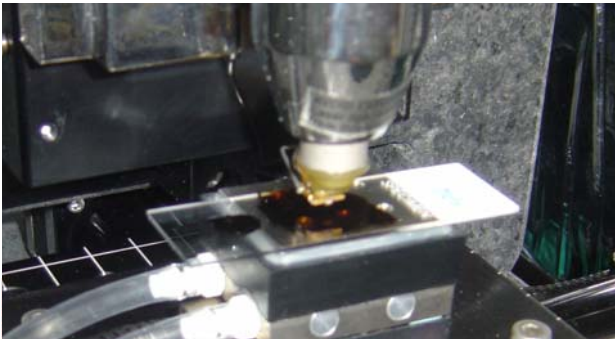
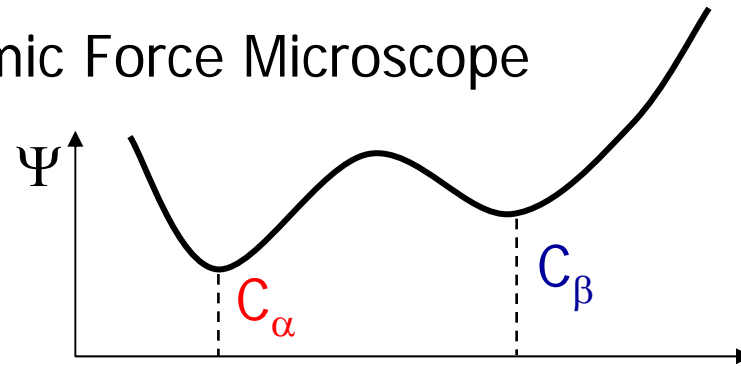
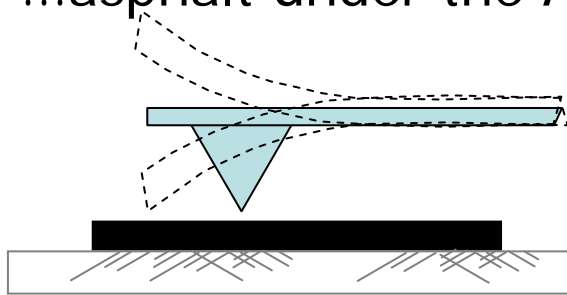

...asphalt under the Atomic Force Microscope

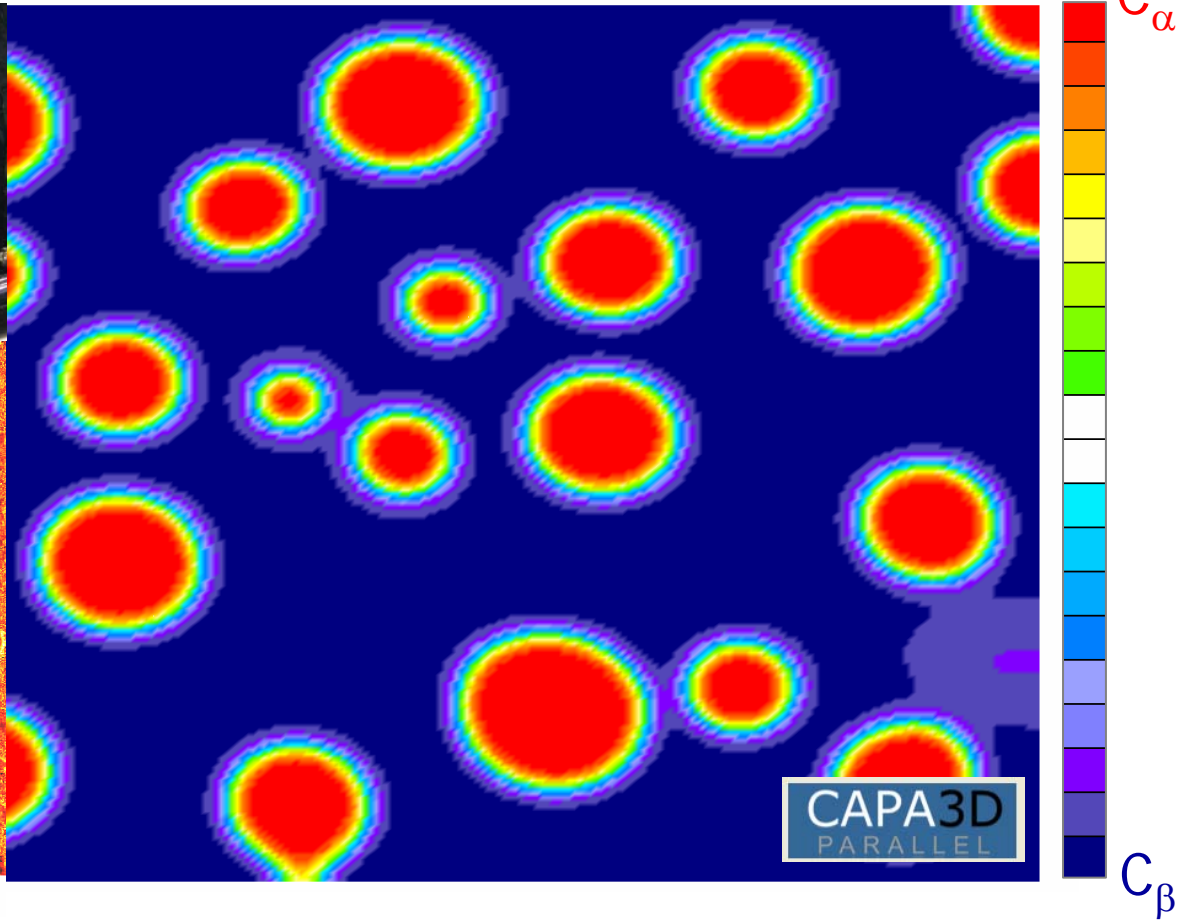
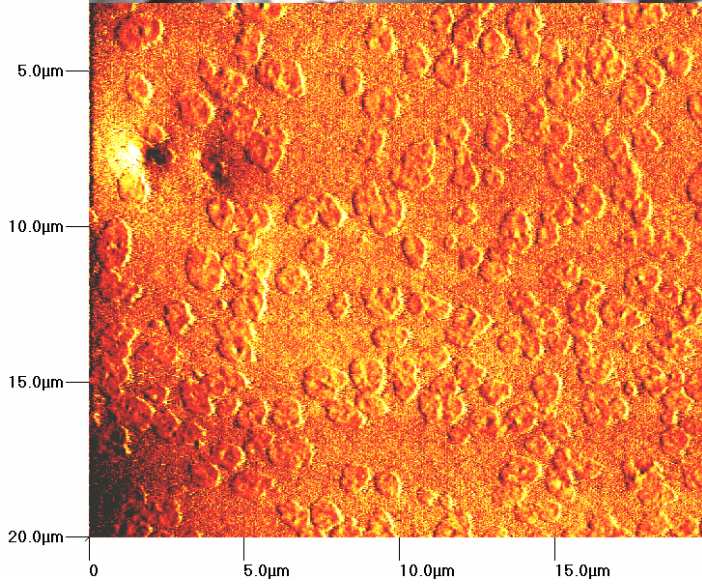
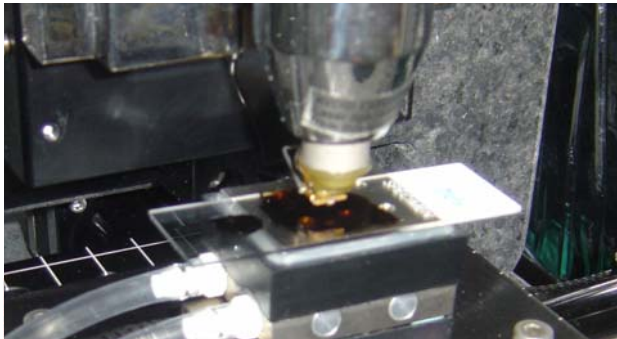
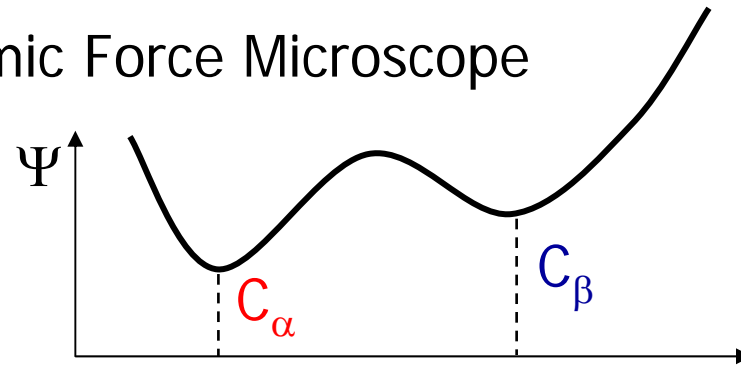
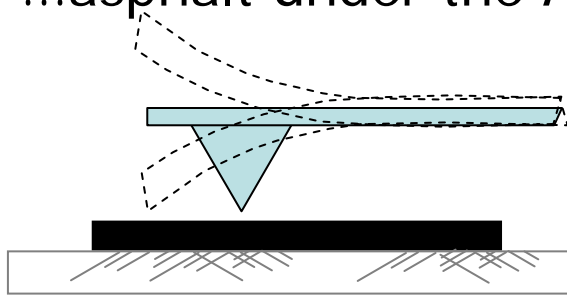

...asphalt under the Atomic Force Microscope

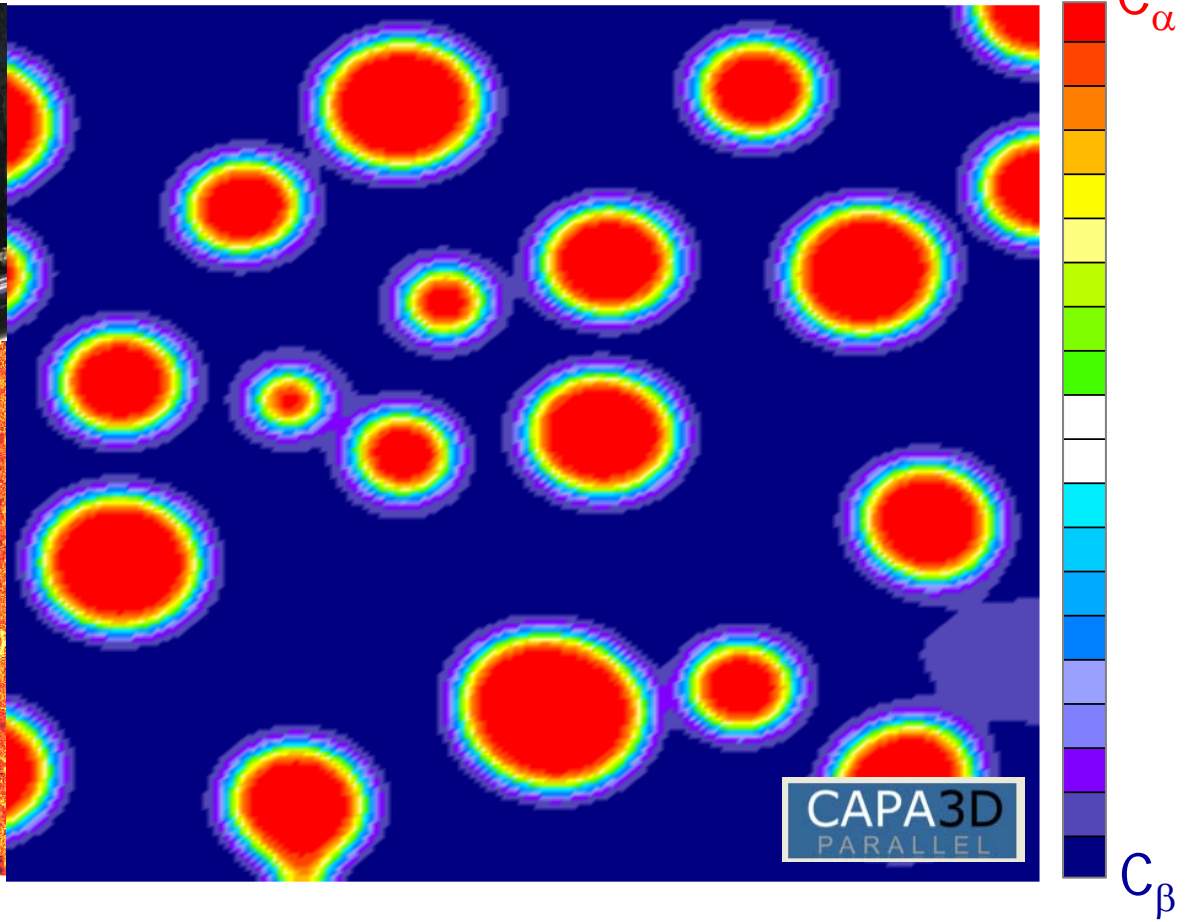
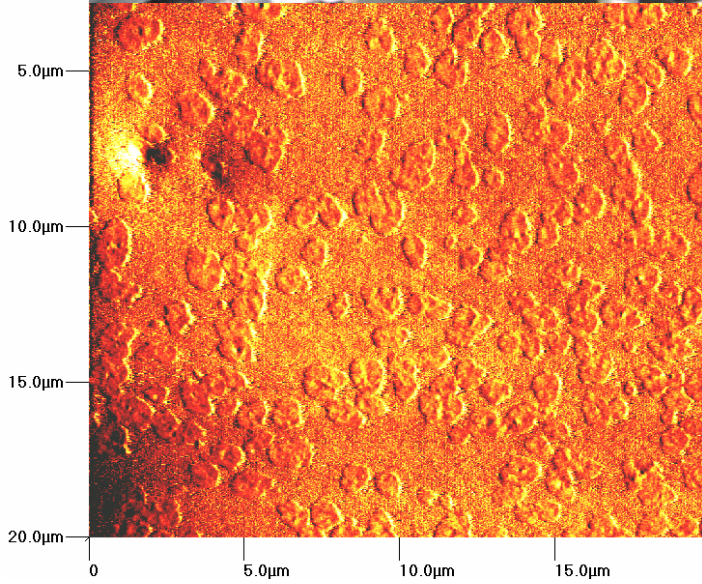
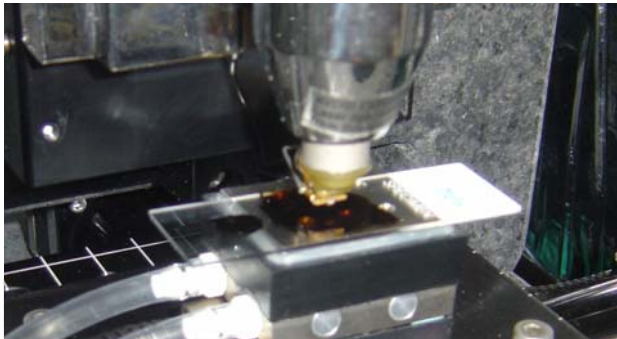
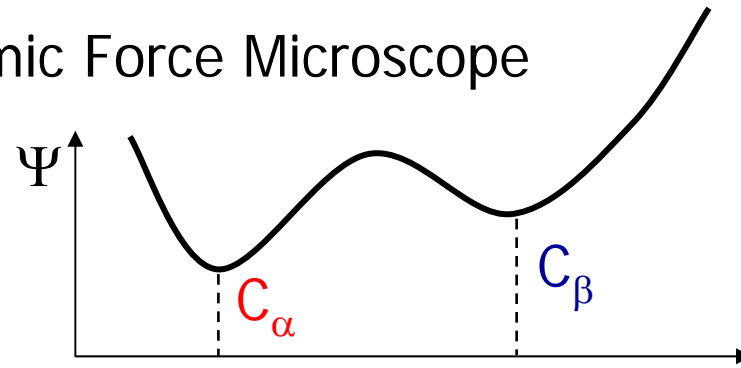
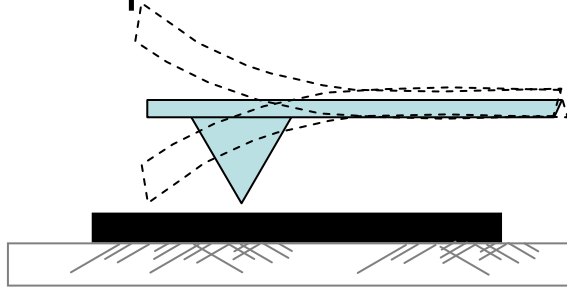

...asphalt under the Atomic Force Microscope

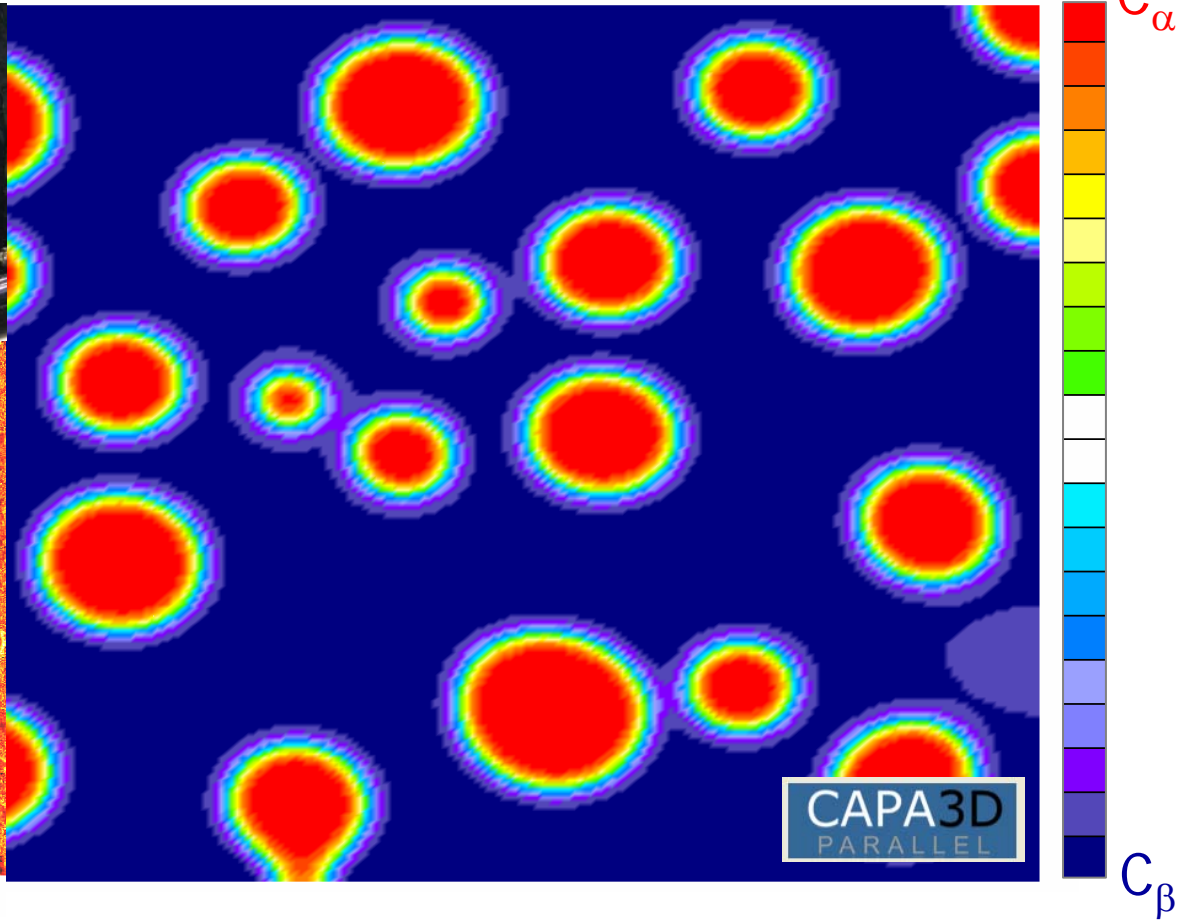
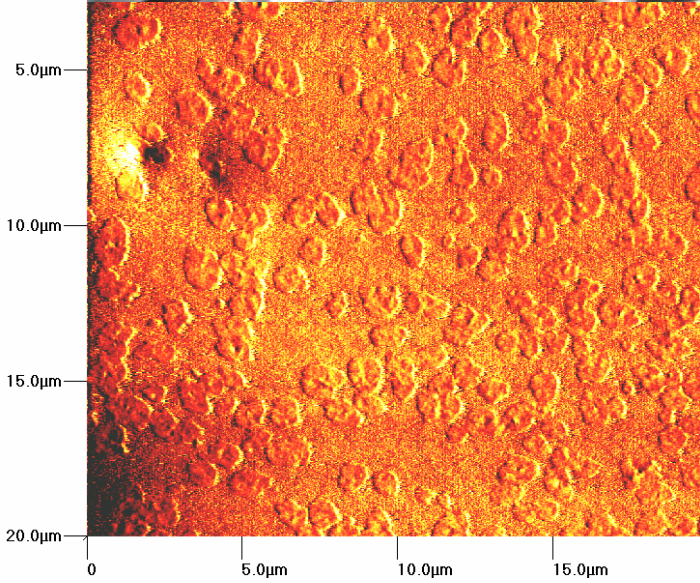
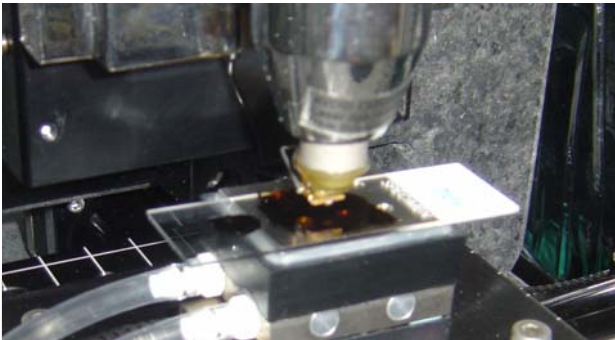
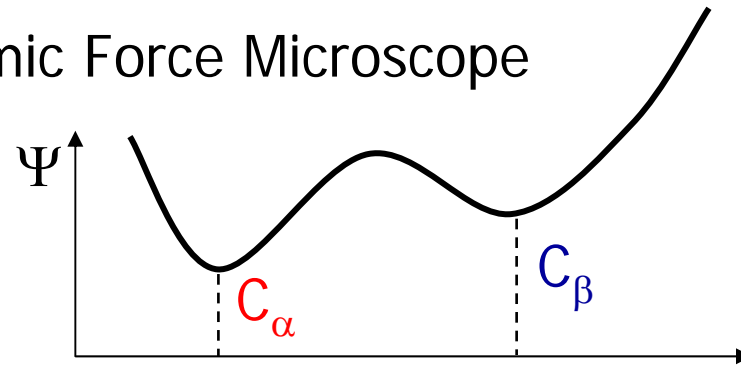
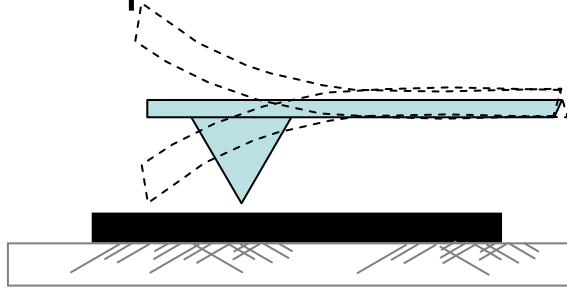

...asphalt under the Atomic Force Microscope

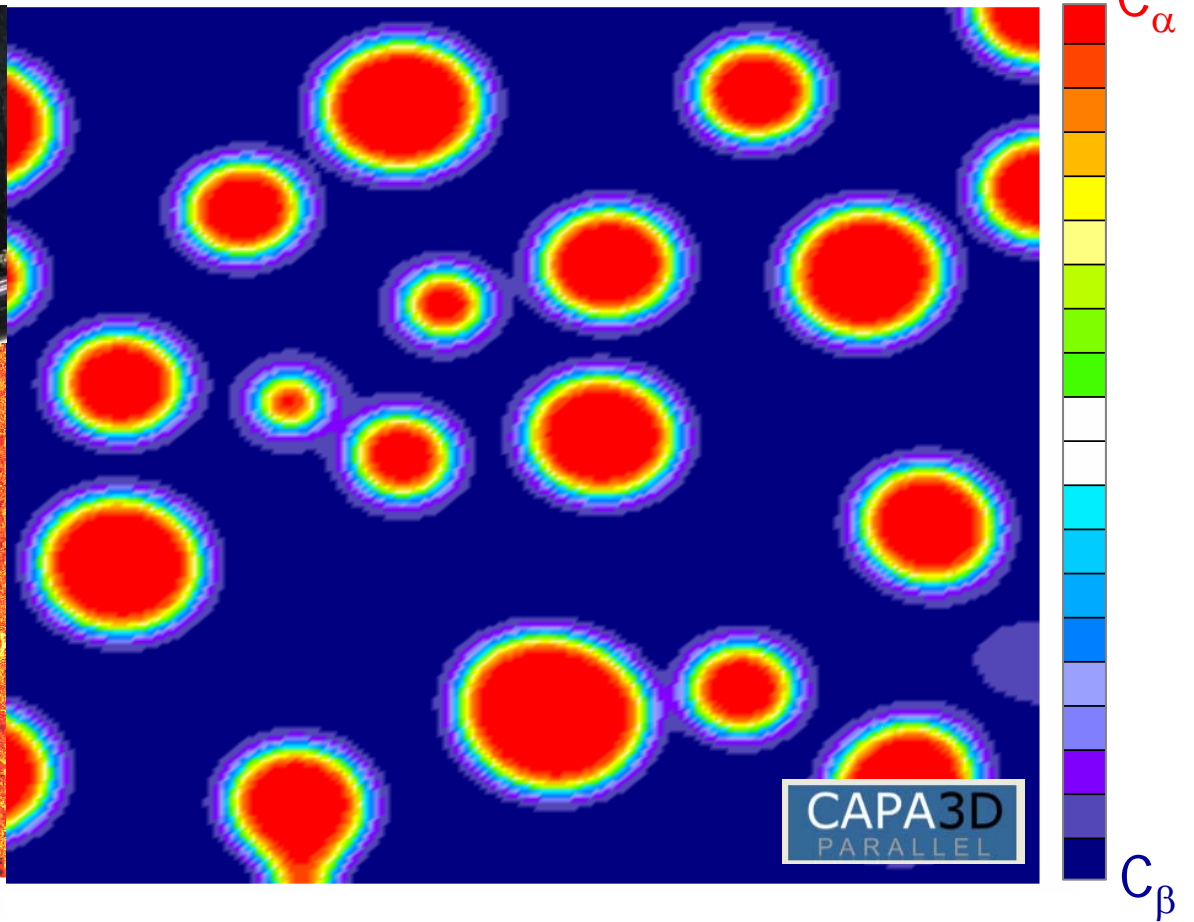
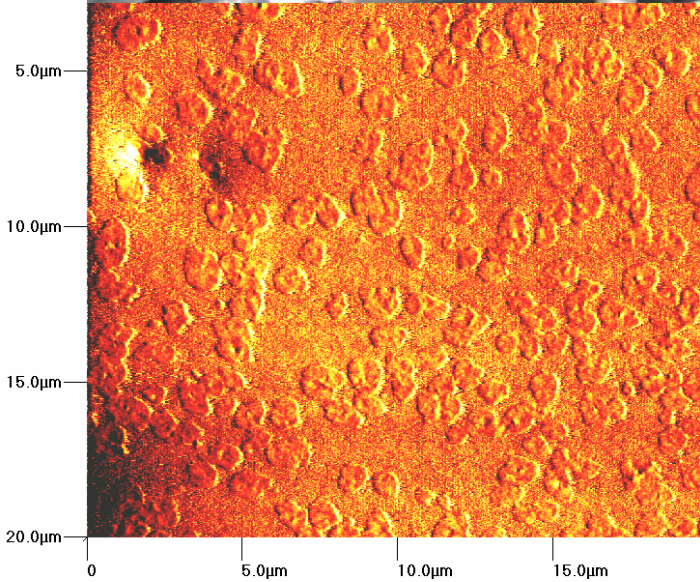
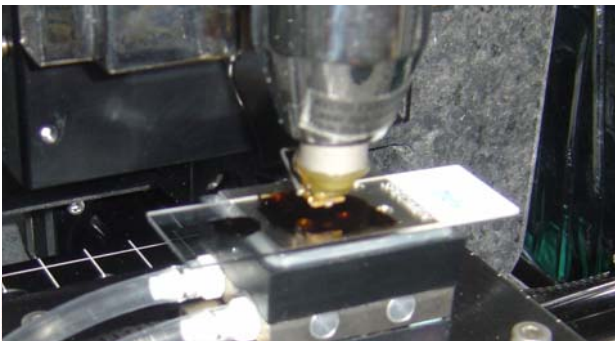
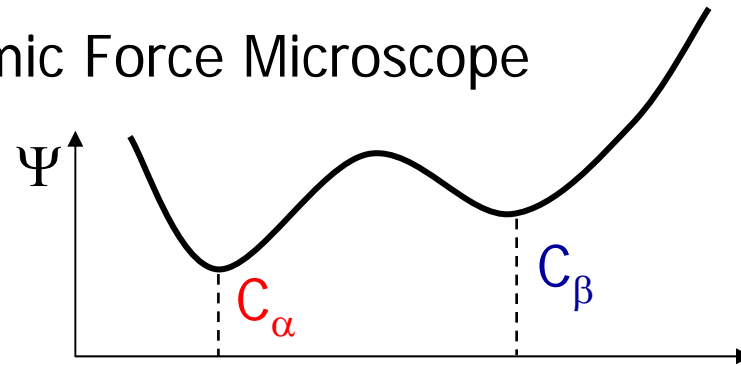
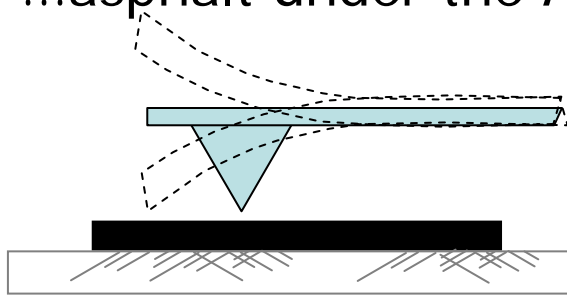

...asphalt under the Atomic Force Microscope

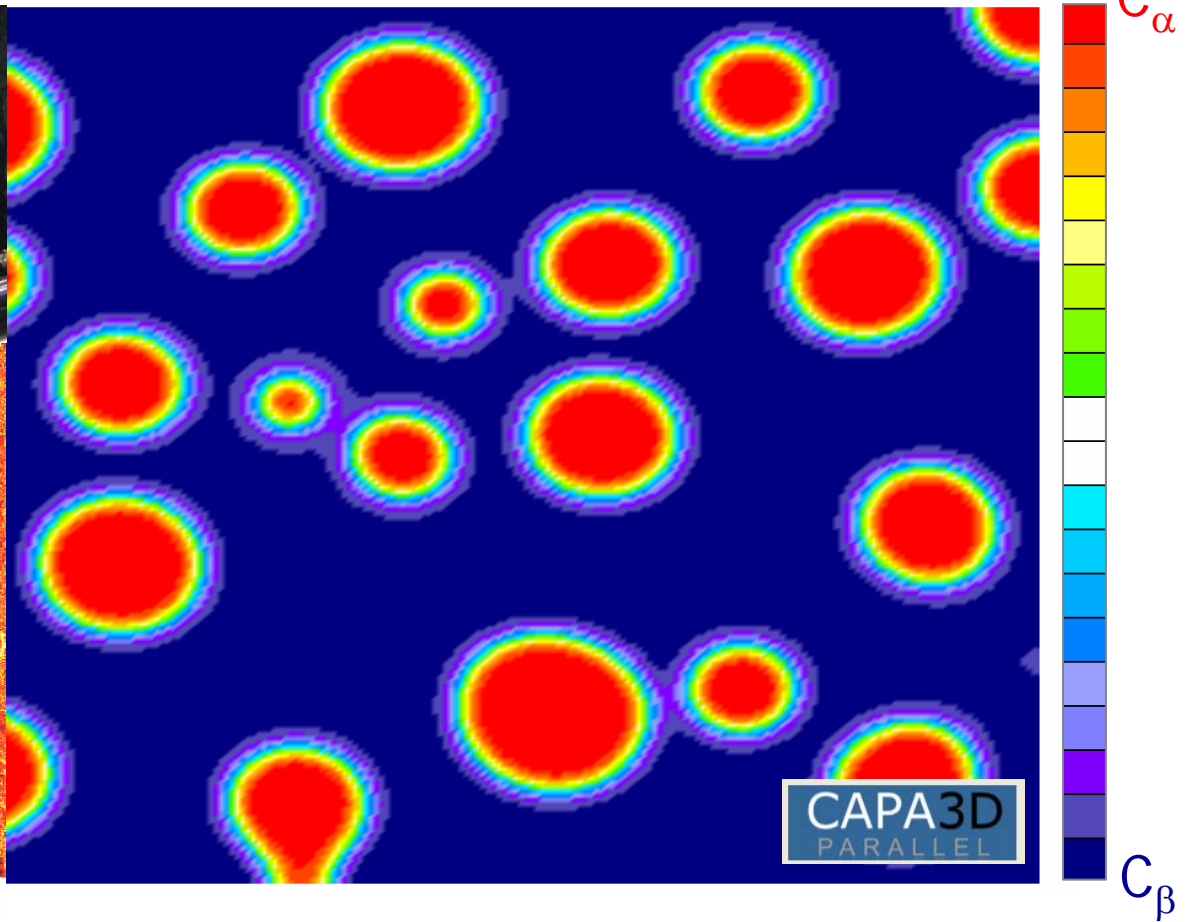
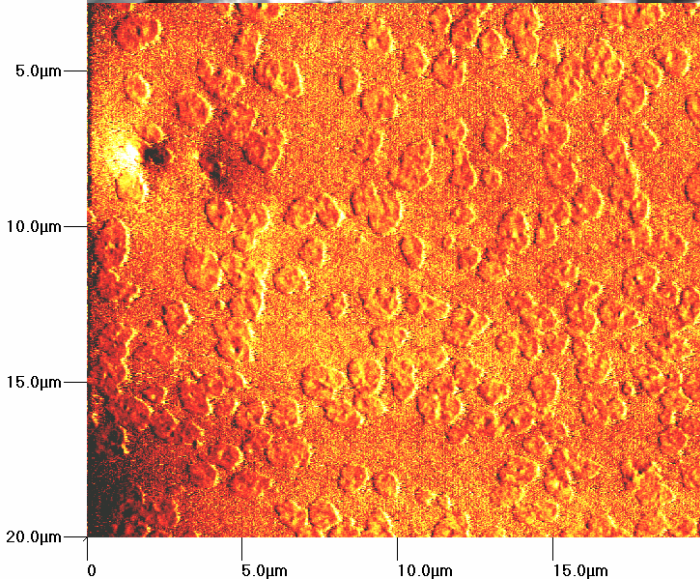
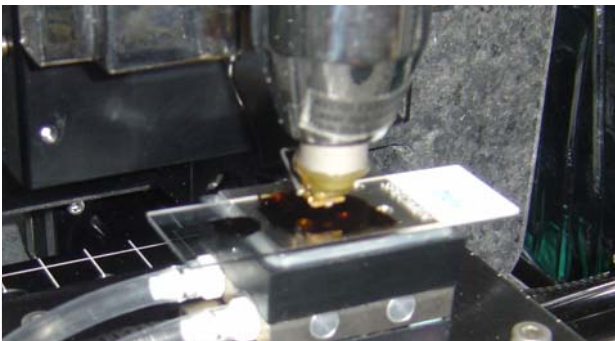
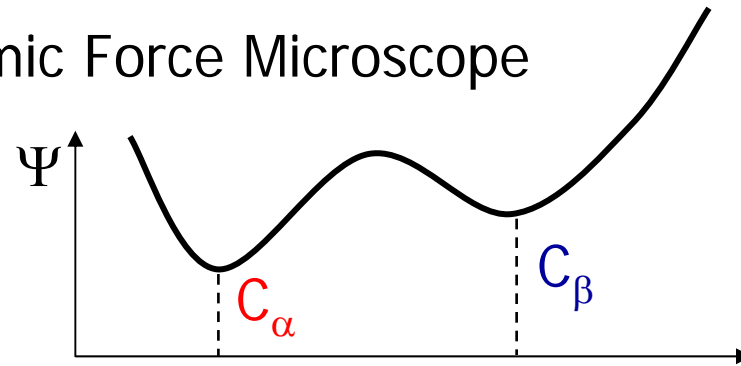
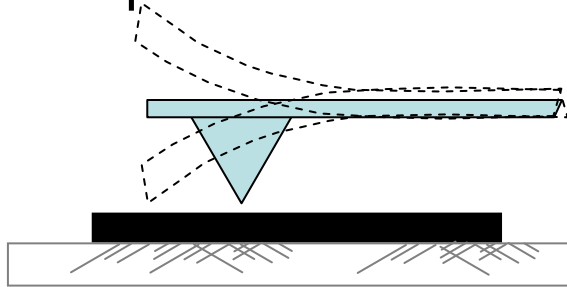

...asphalt under the Atomic Force Microscope

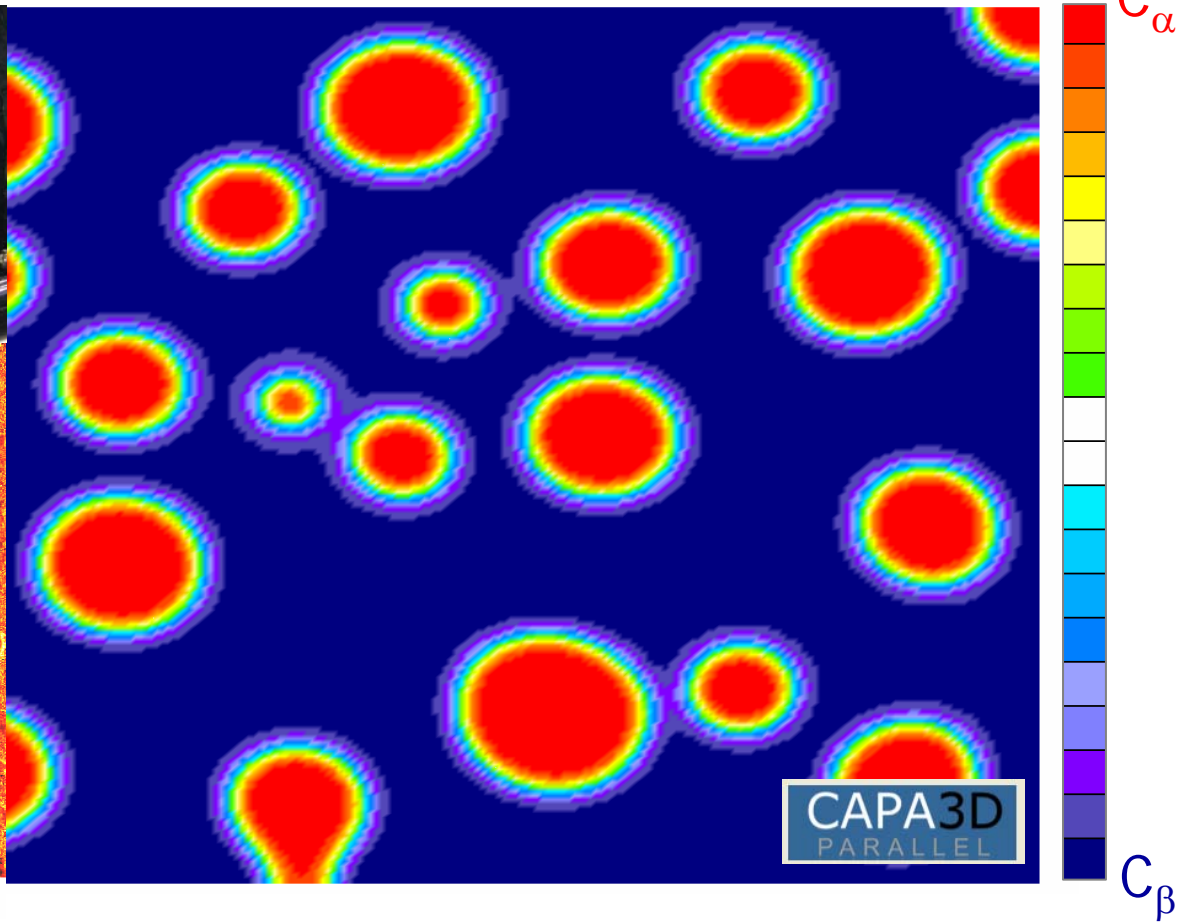
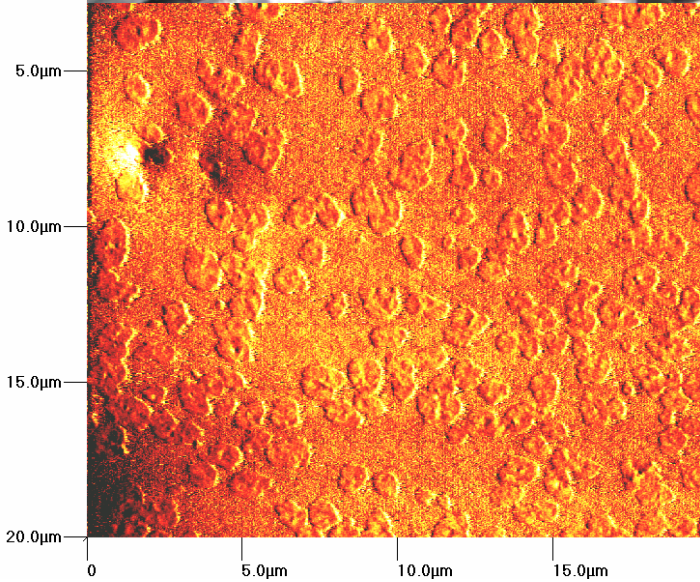
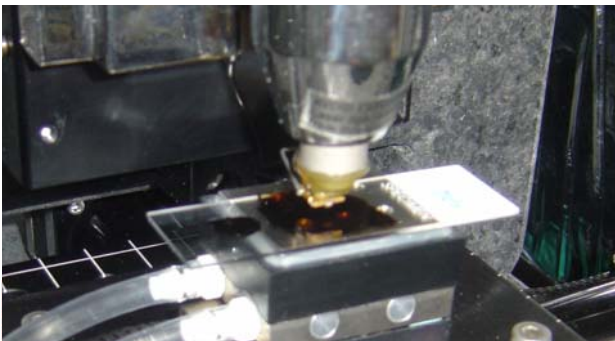
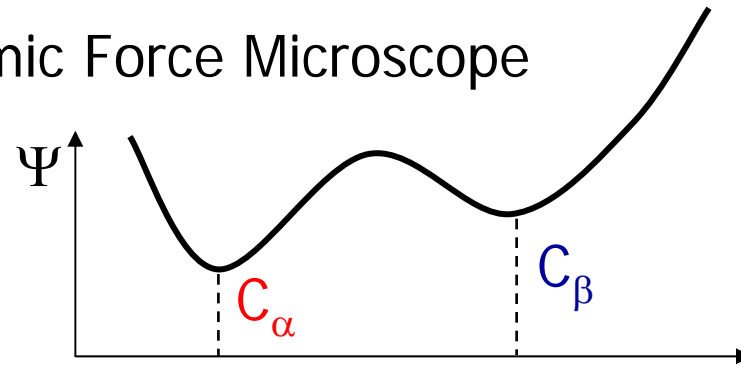
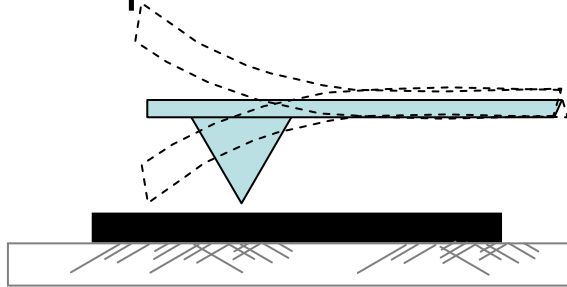

...asphalt under the Atomic Force Microscope

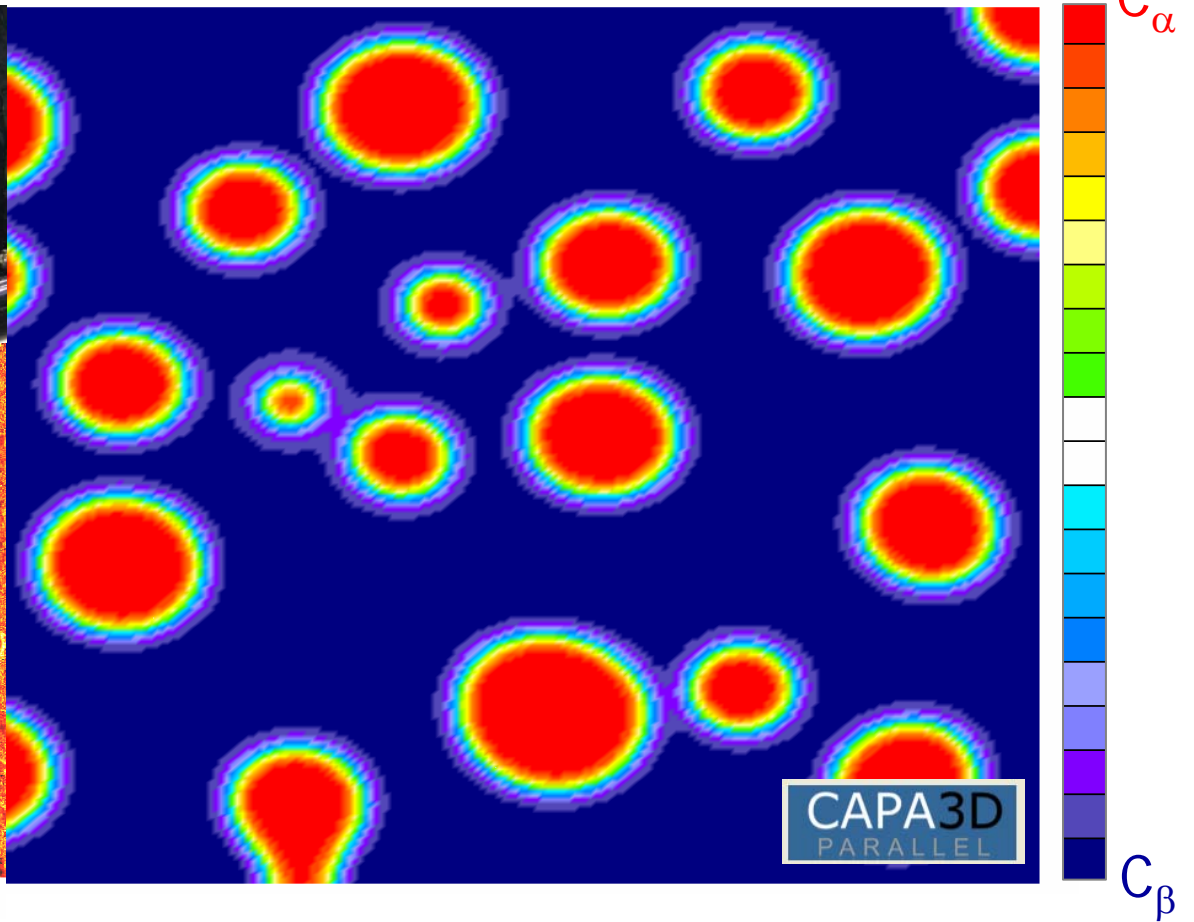
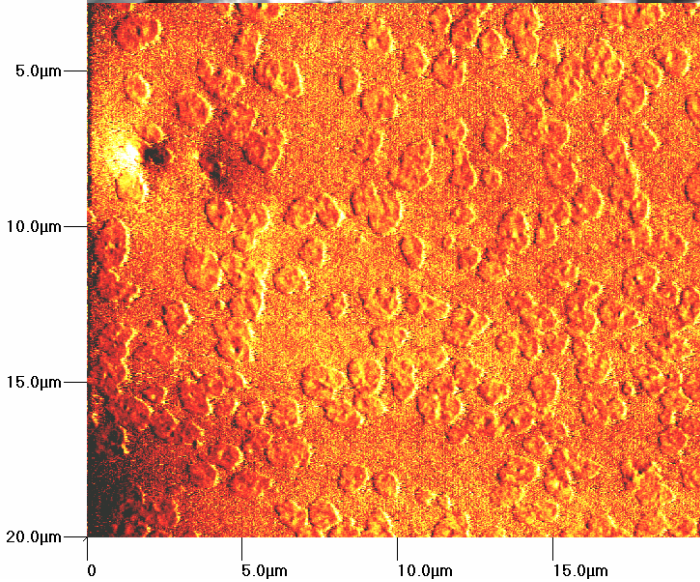
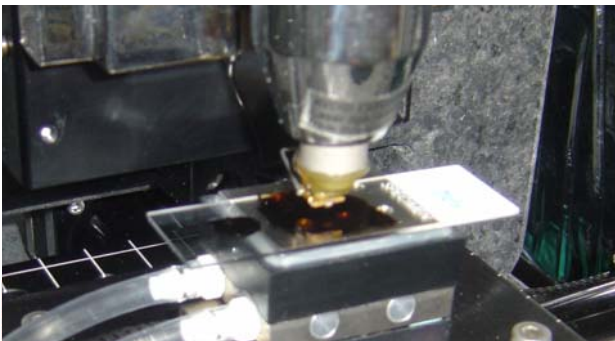
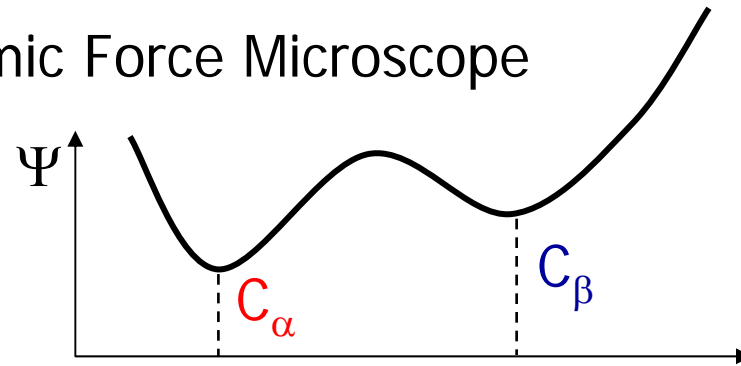
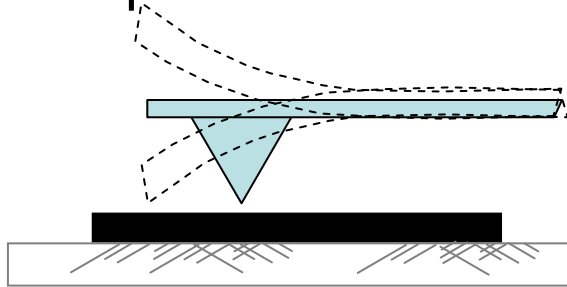

...asphalt under the Atomic Force Microscope

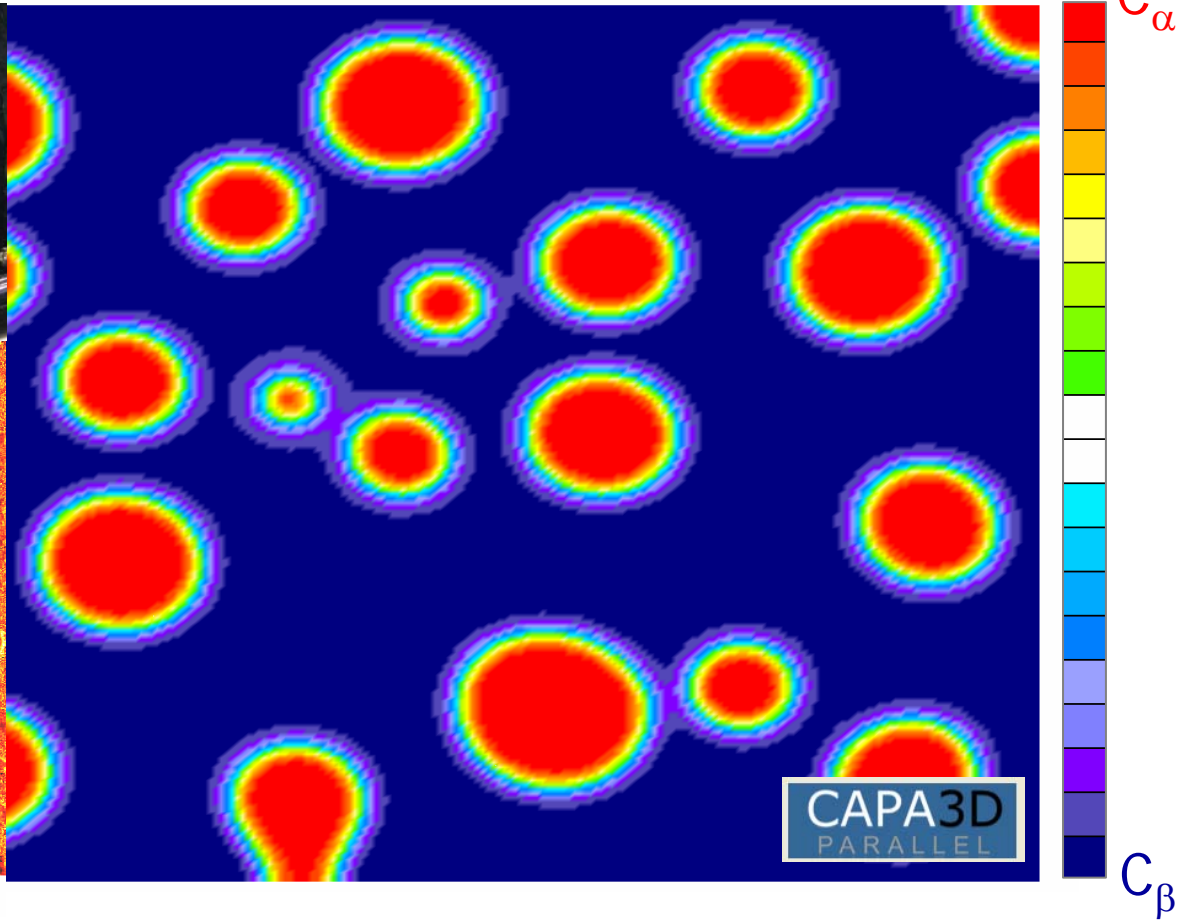
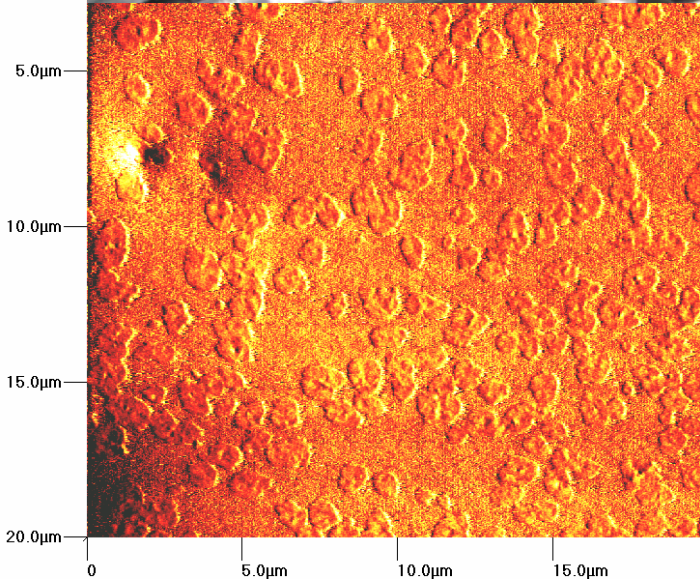
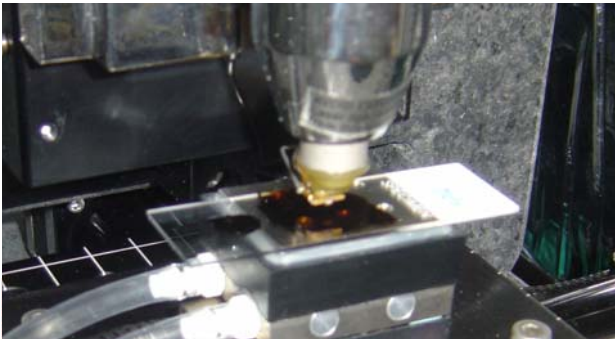
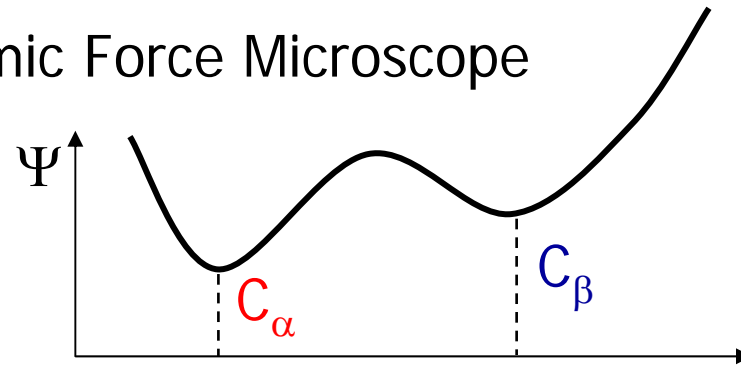
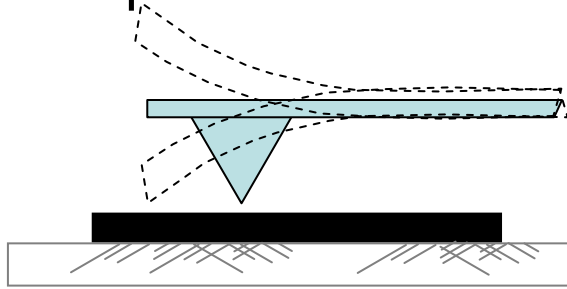

...asphalt under the Atomic Force Microscope

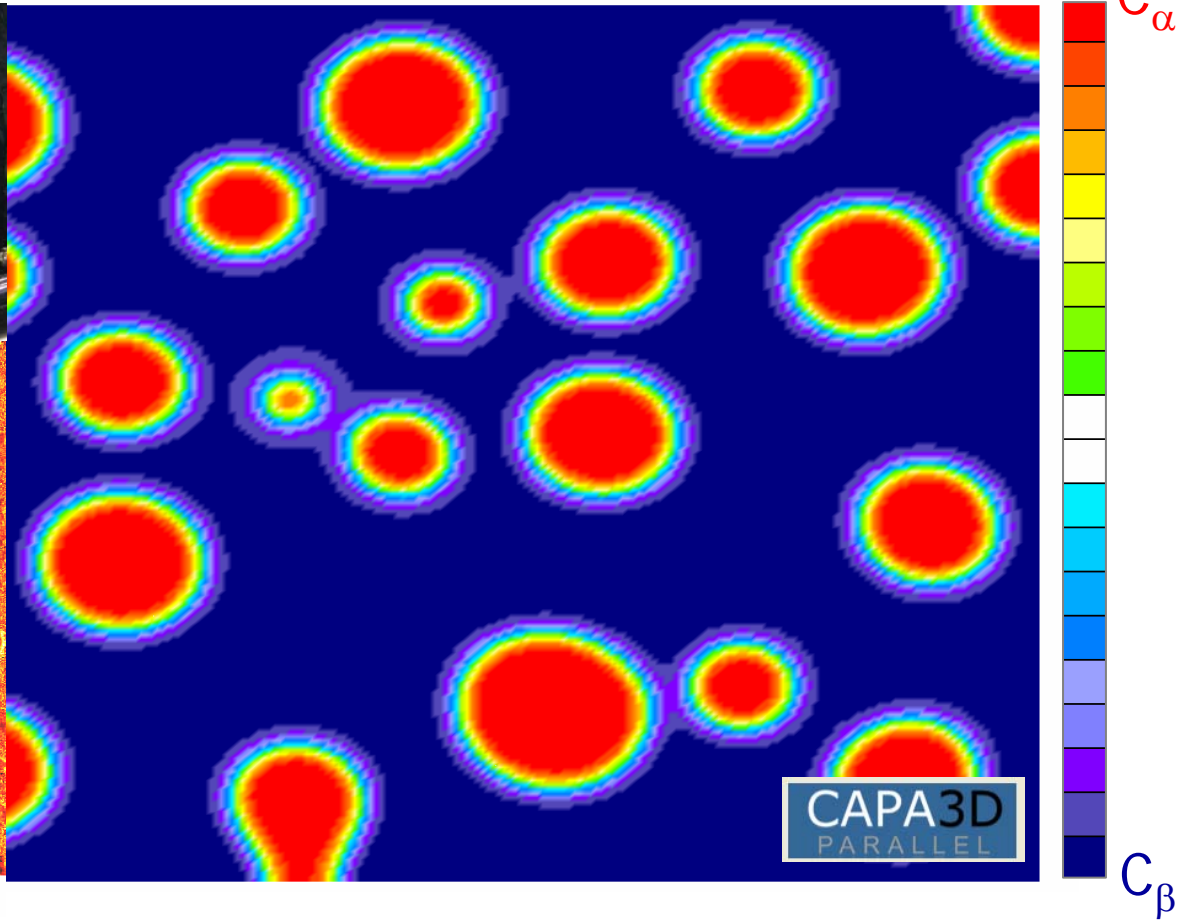
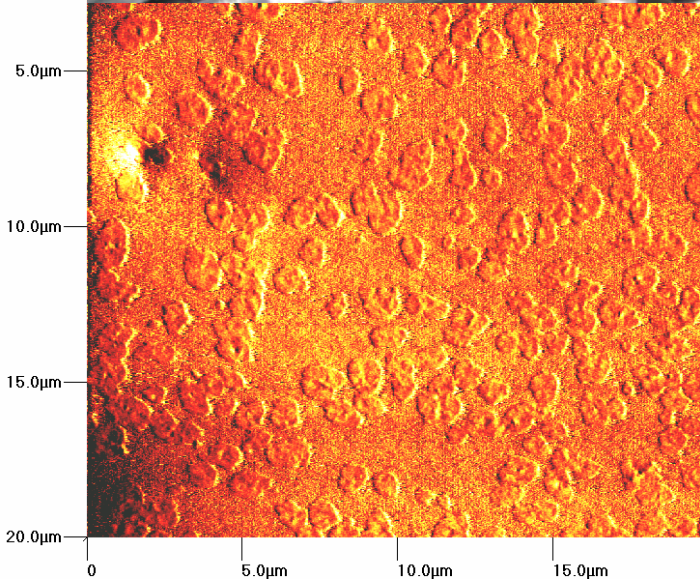
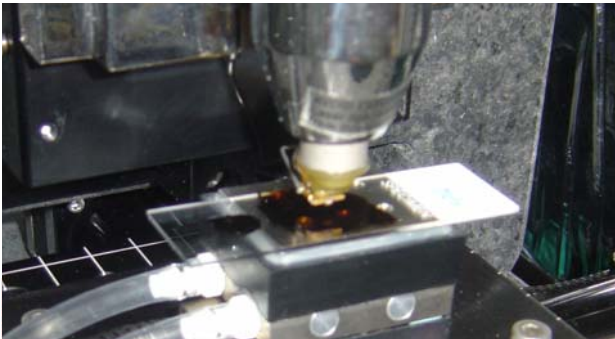
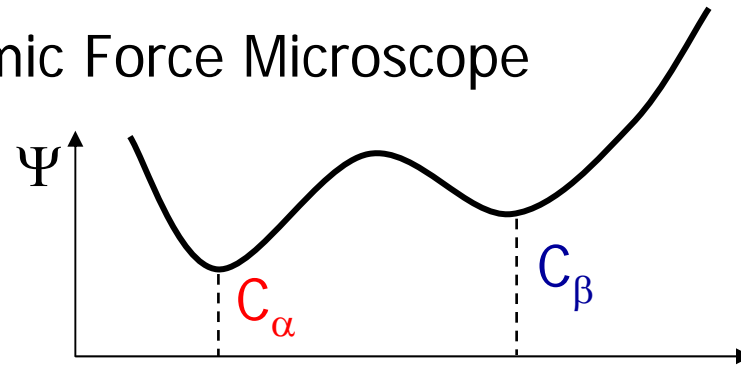
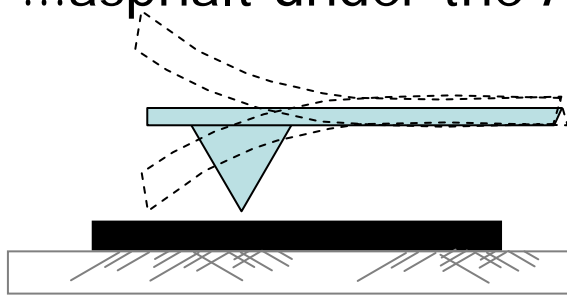

...asphalt under the Atomic Force Microscope

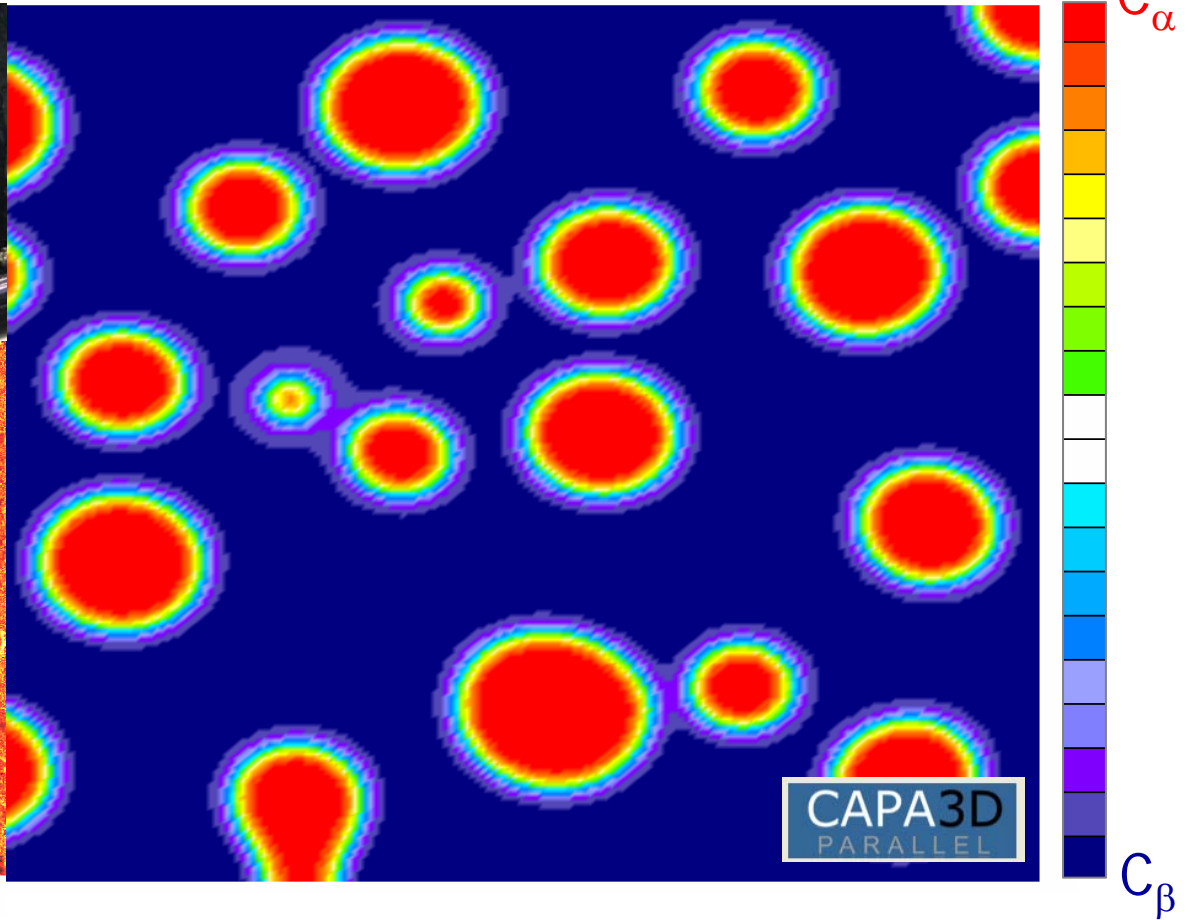
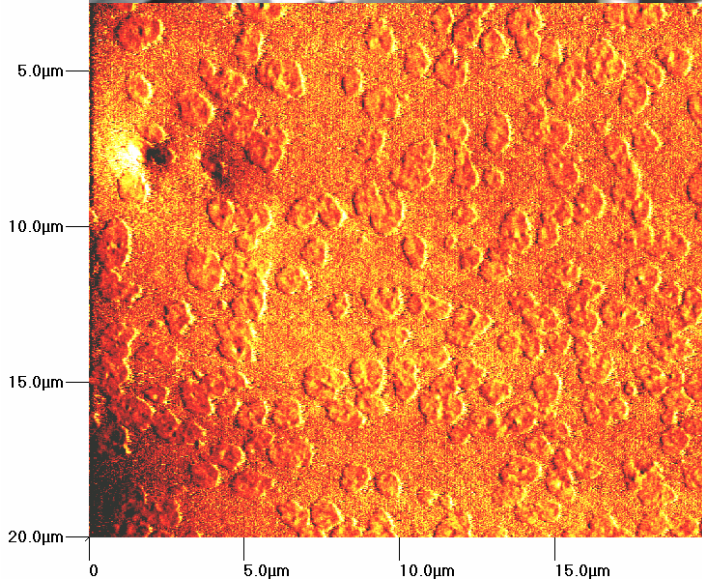
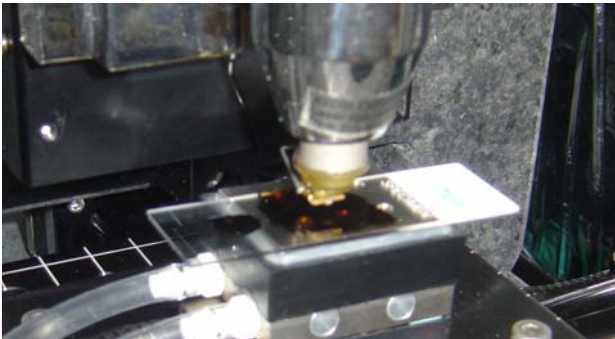
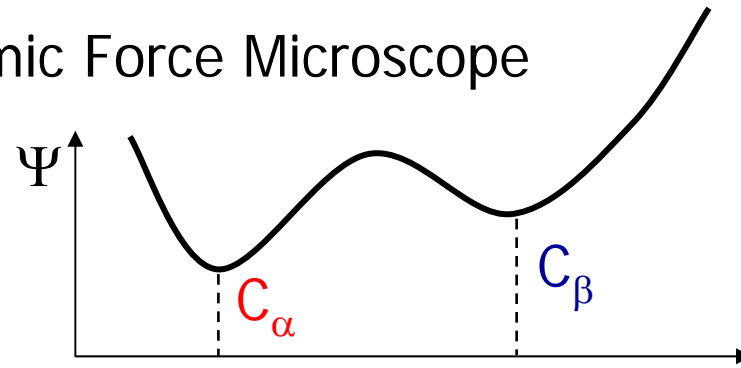
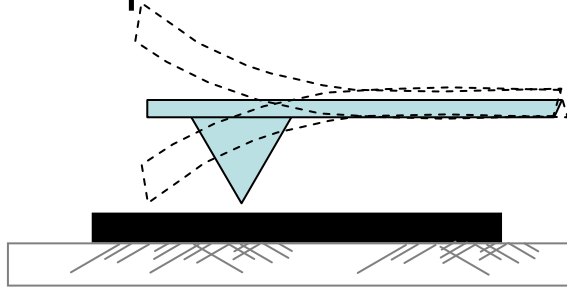

...asphalt under the Atomic Force Microscope

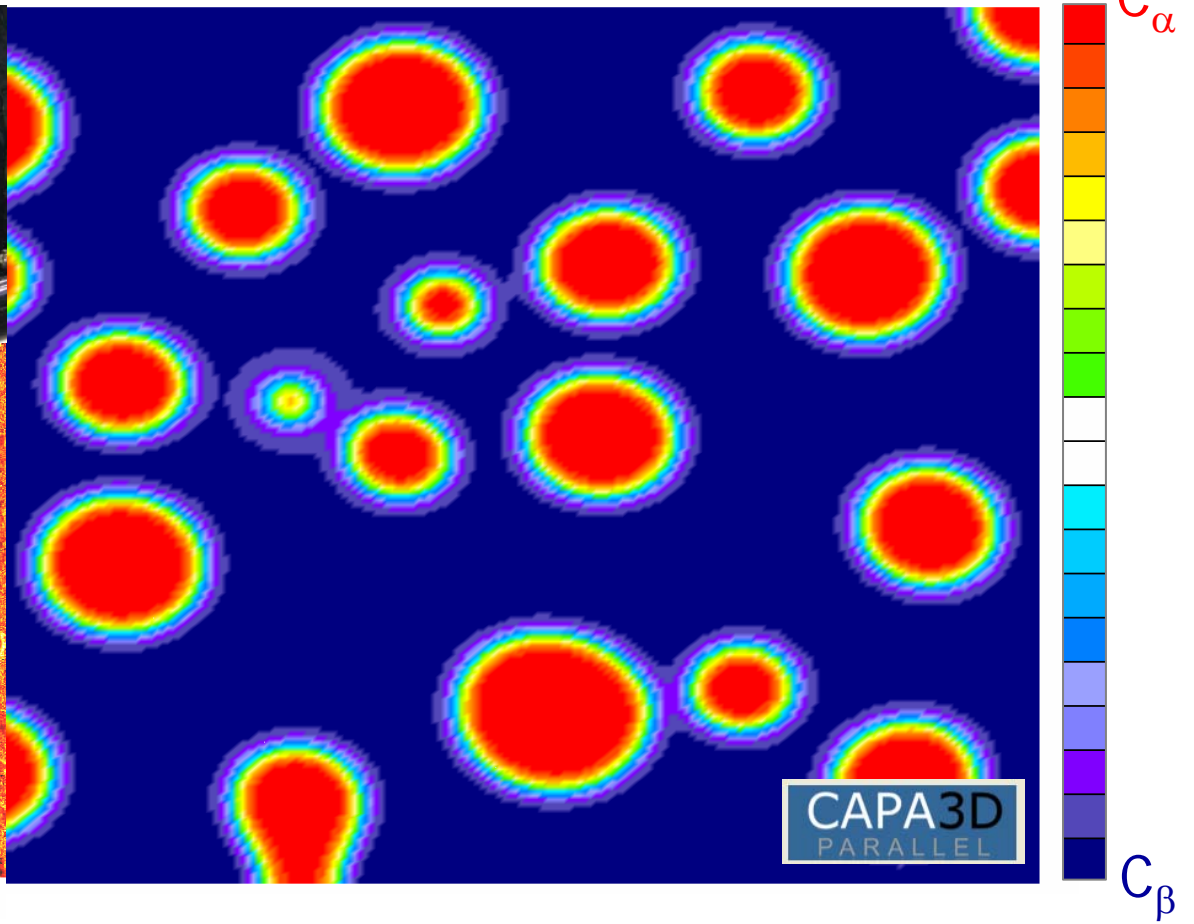
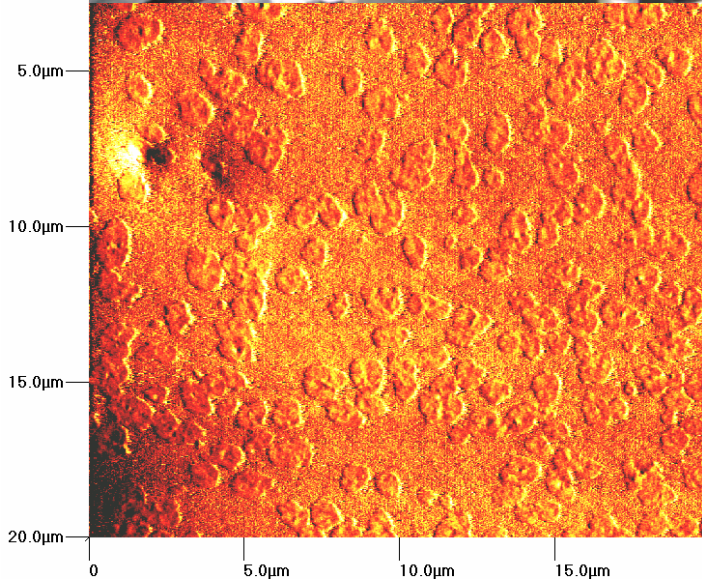
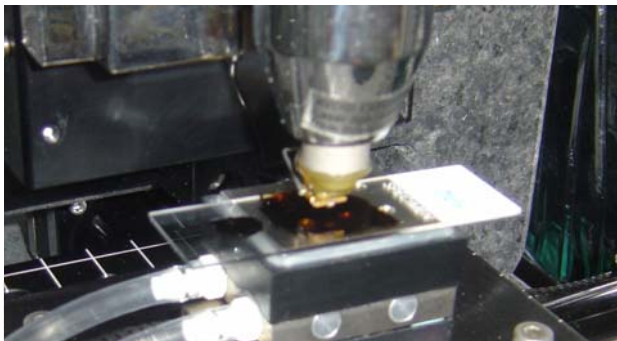
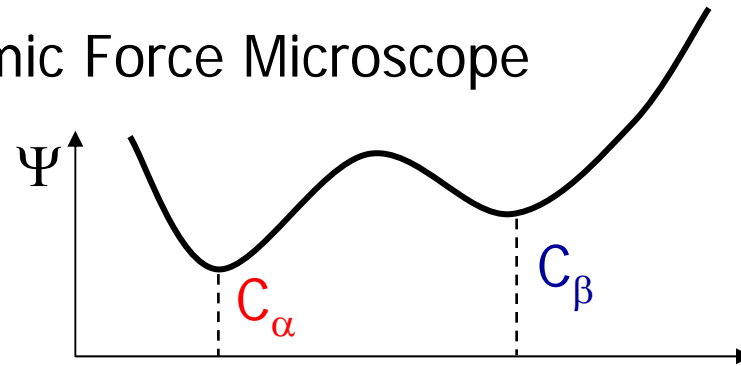
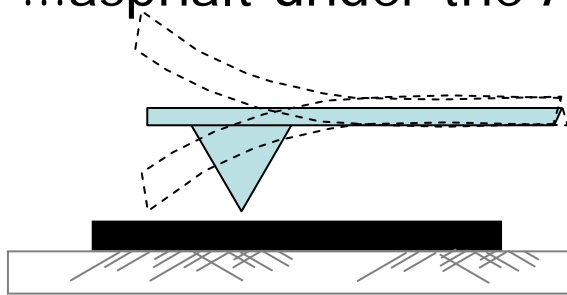

...asphalt under the Atomic Force Microscope

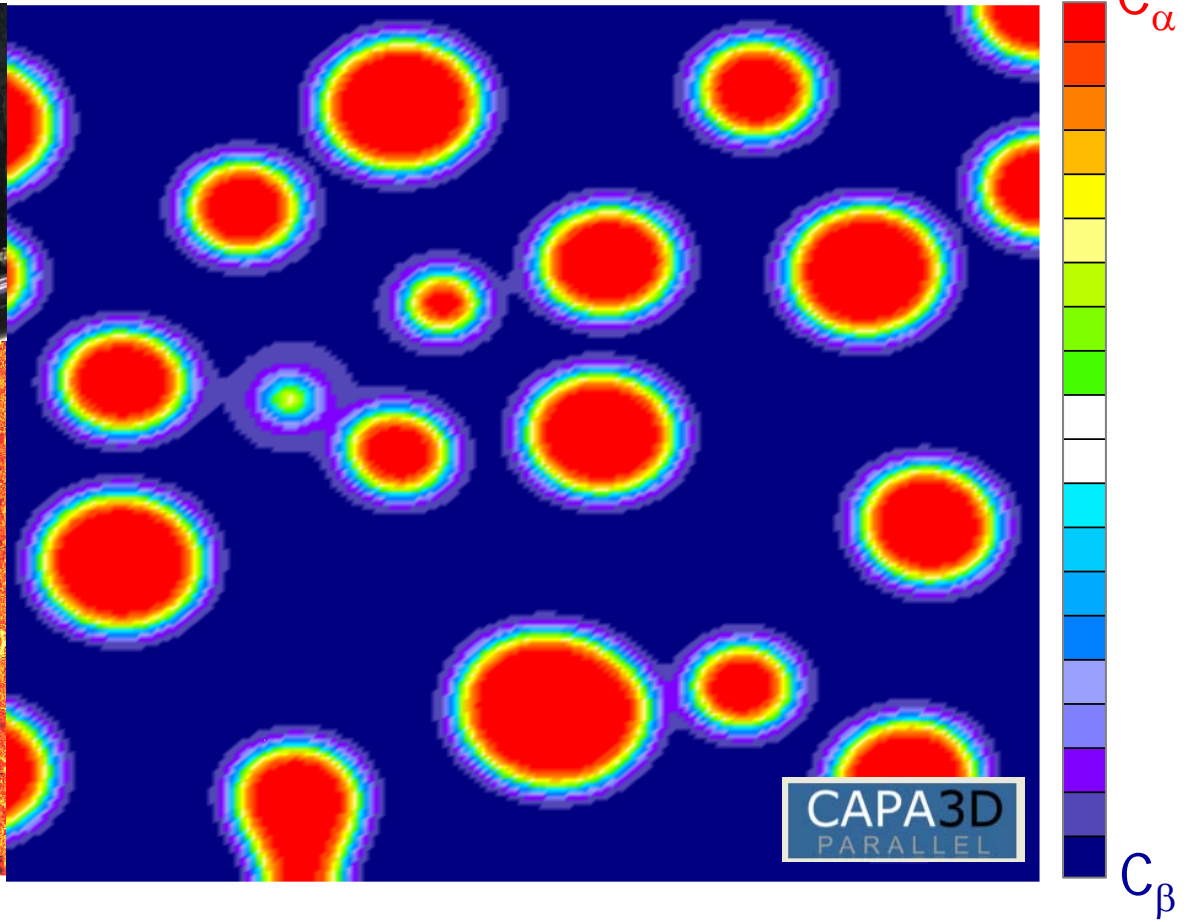
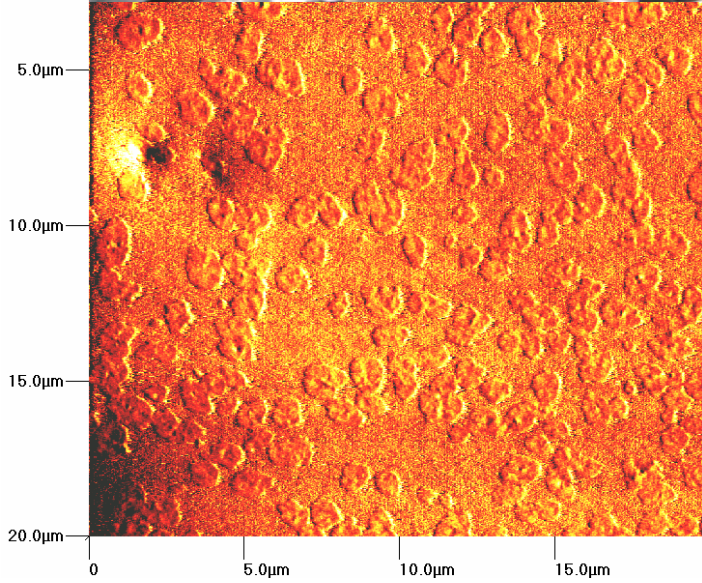
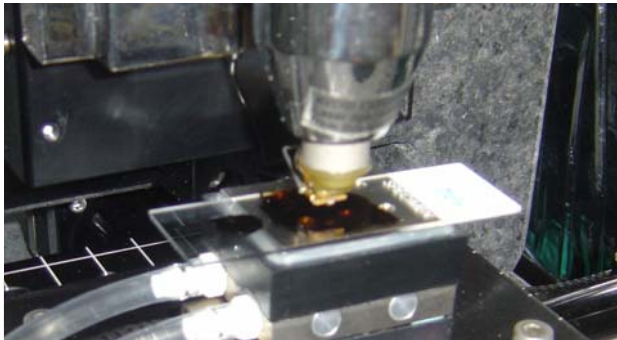
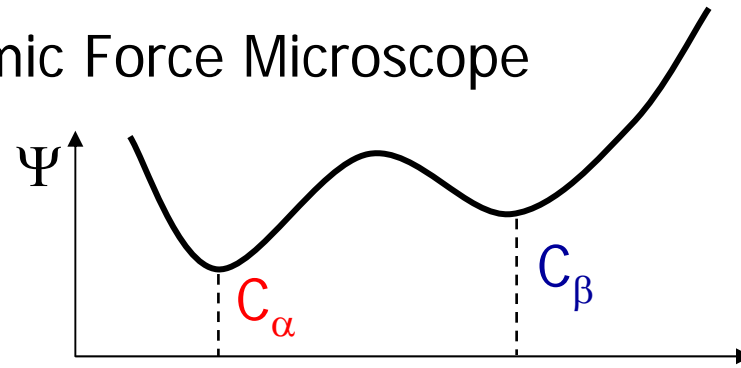
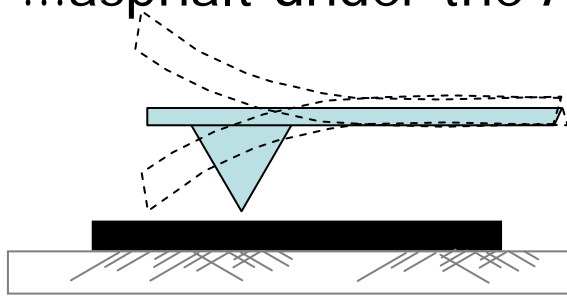

...asphalt under the Atomic Force Microscope

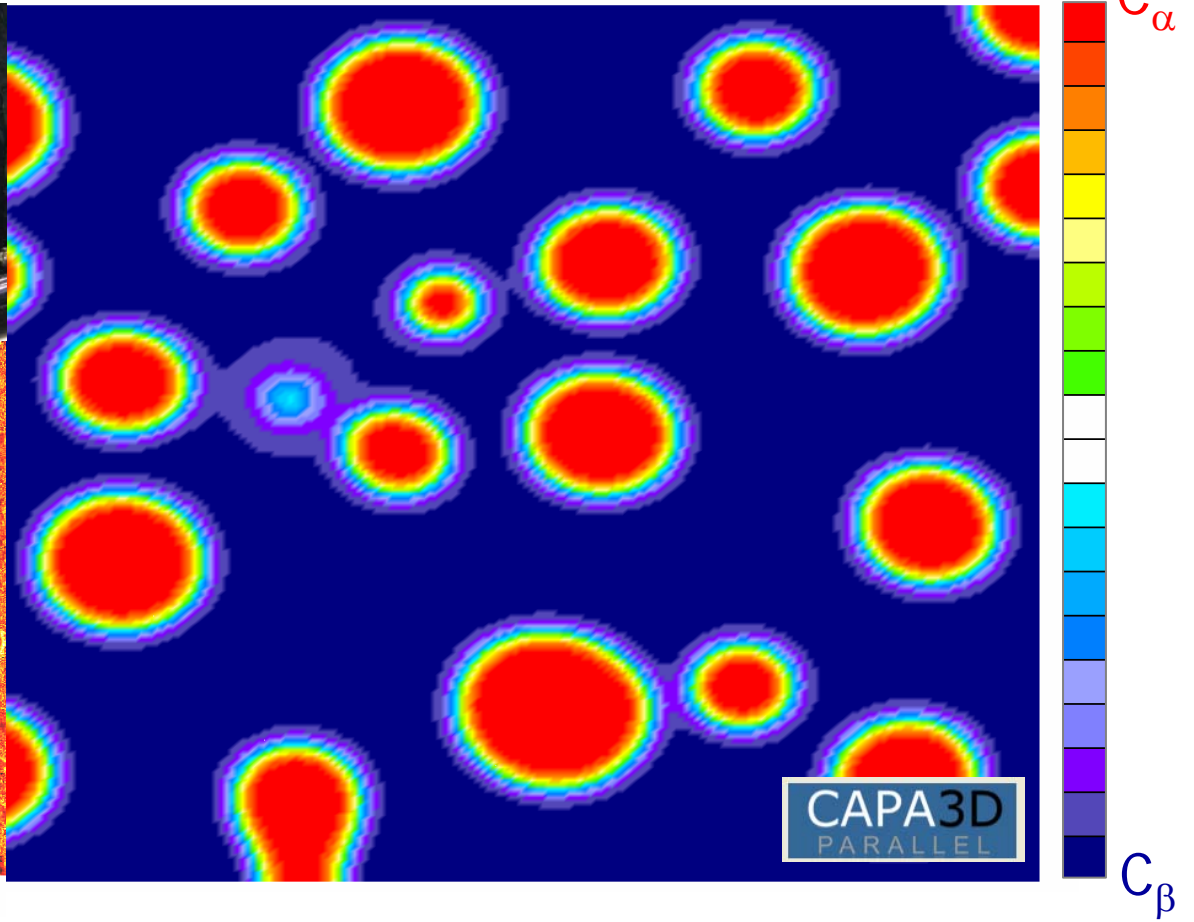
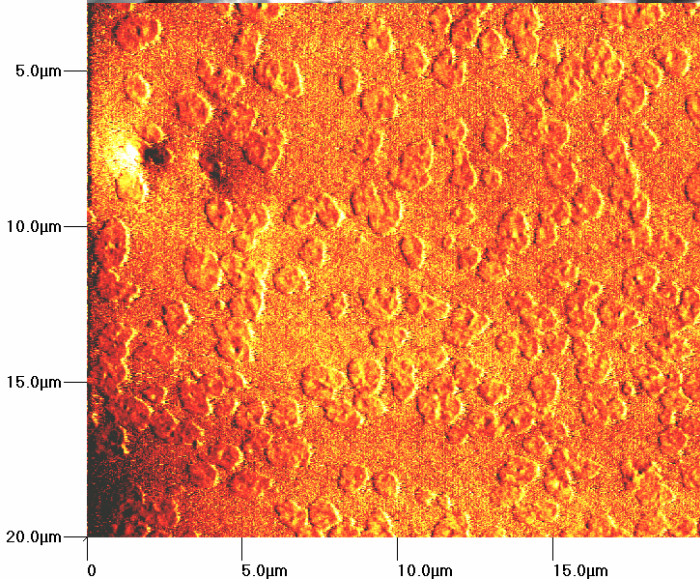
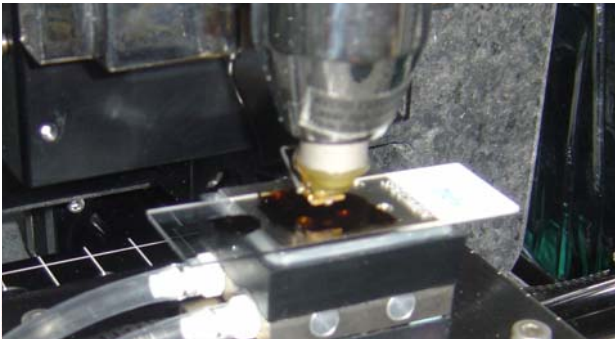
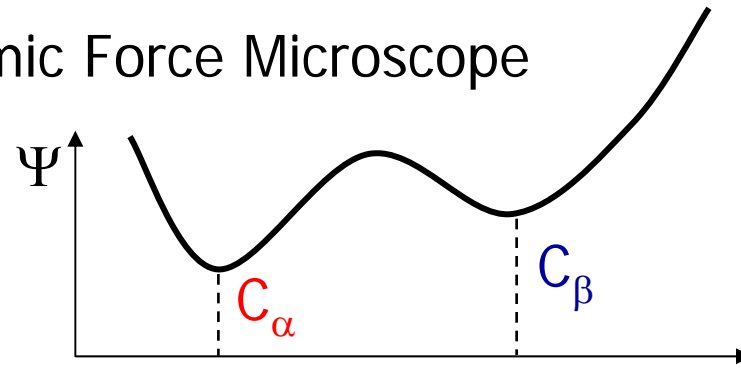
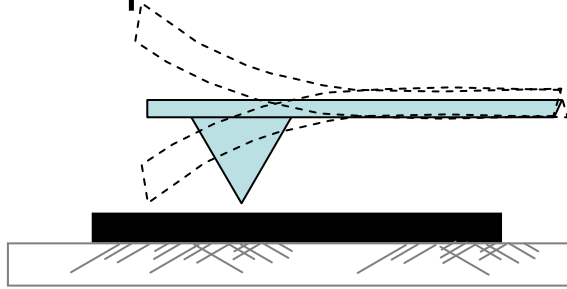

...asphalt under the Atomic Force Microscope

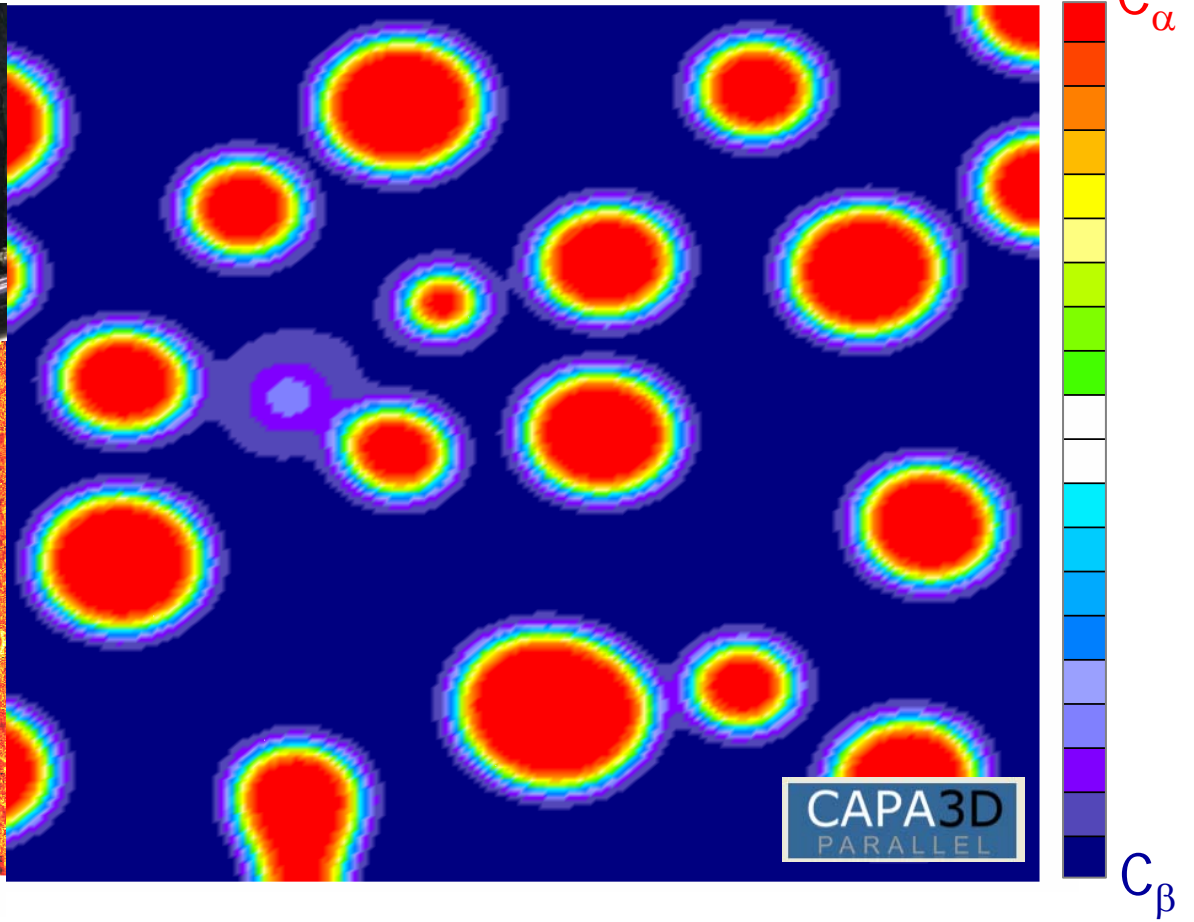
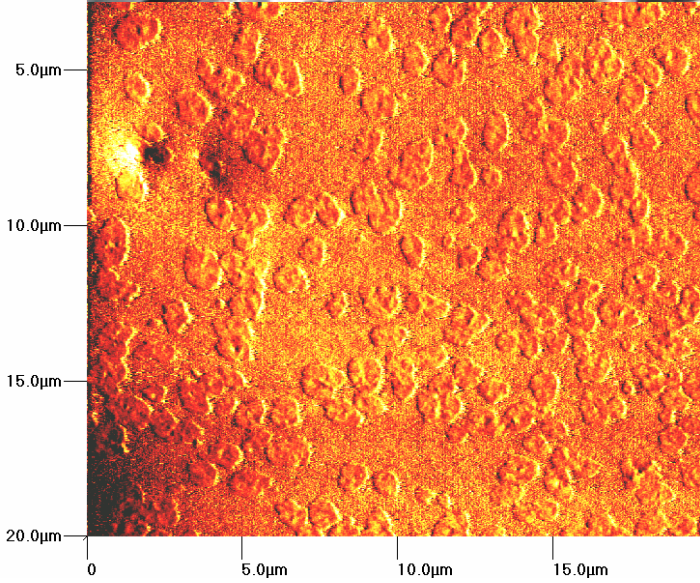
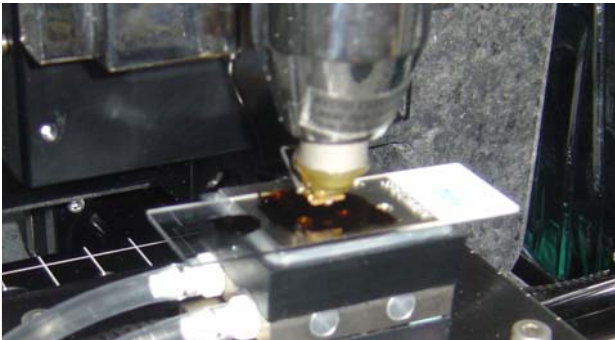
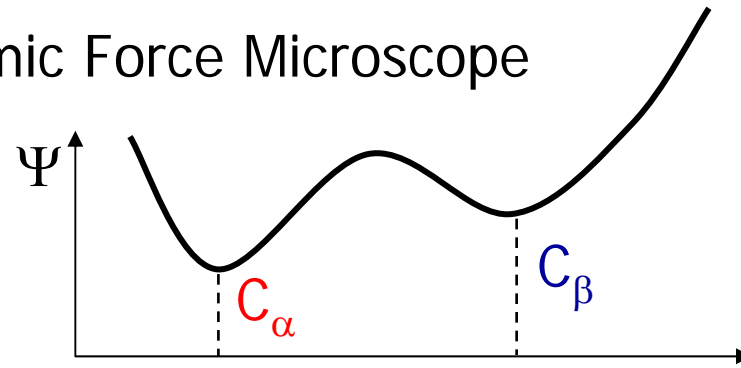
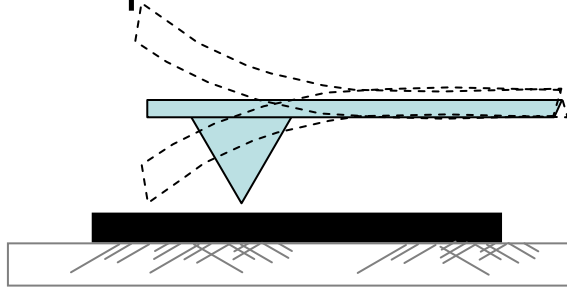

...asphalt under the Atomic Force Microscope

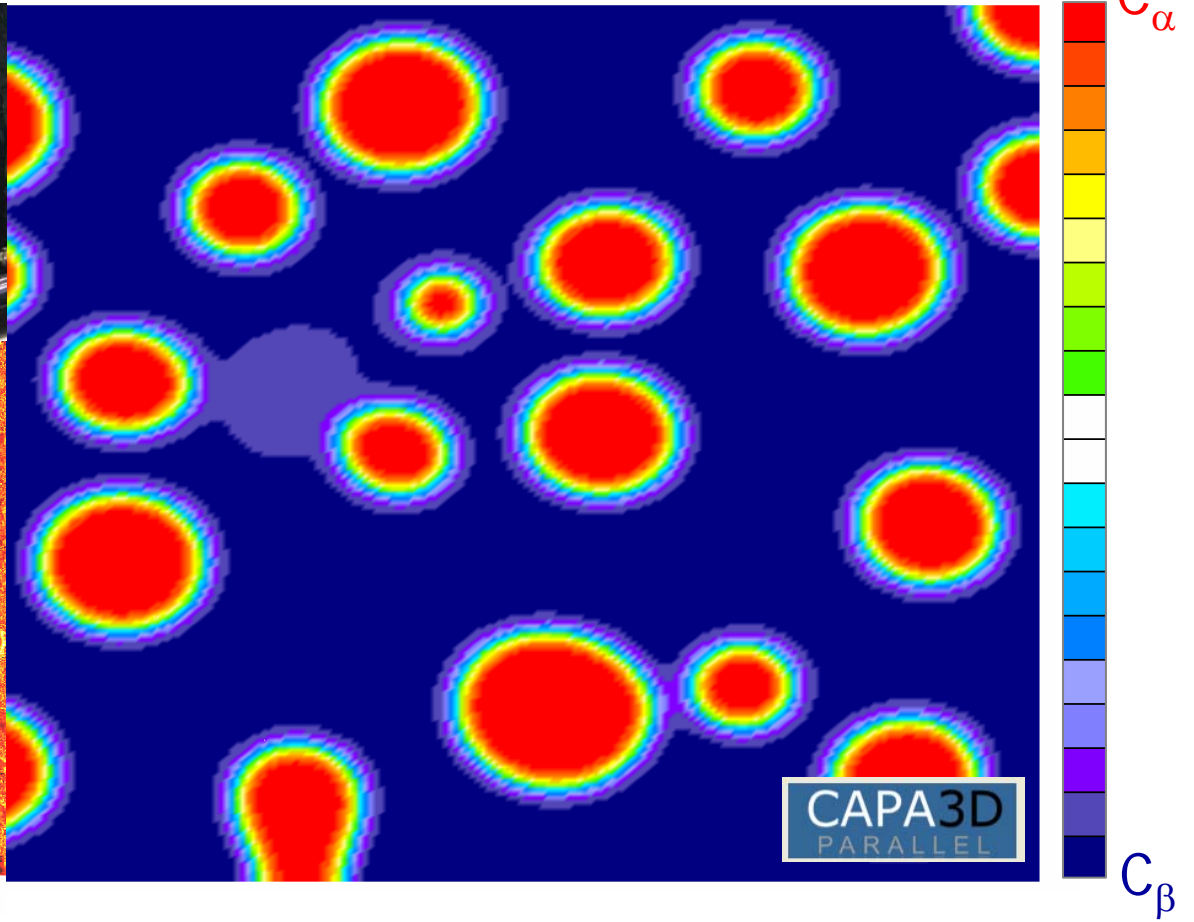
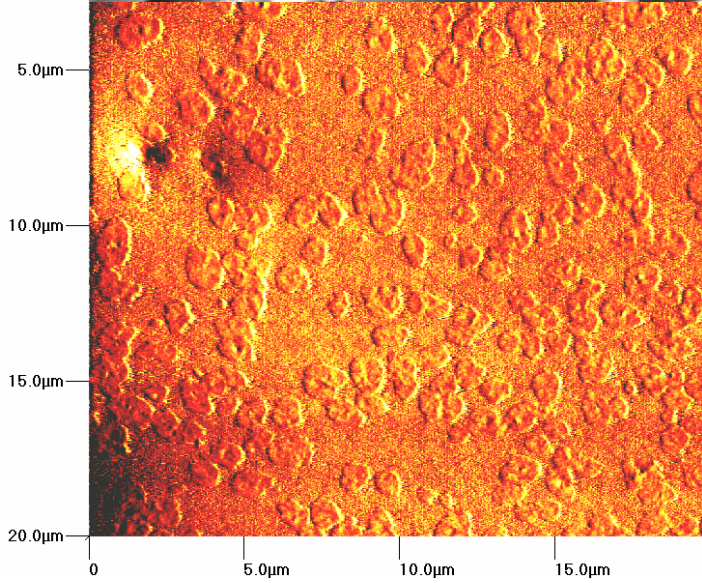
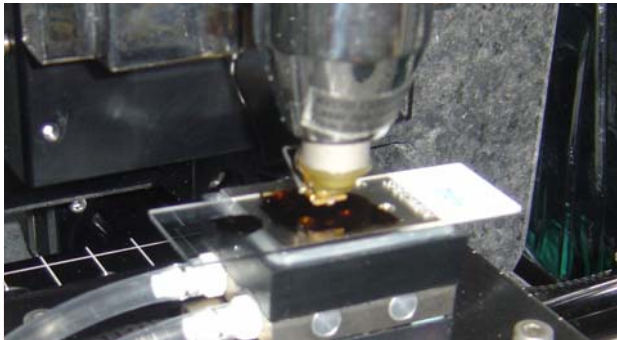
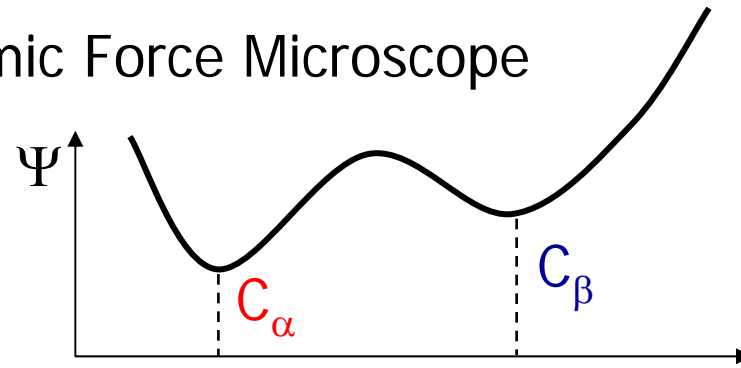
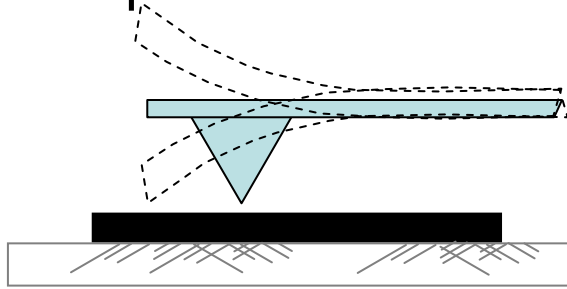

...asphalt under the Atomic Force Microscope

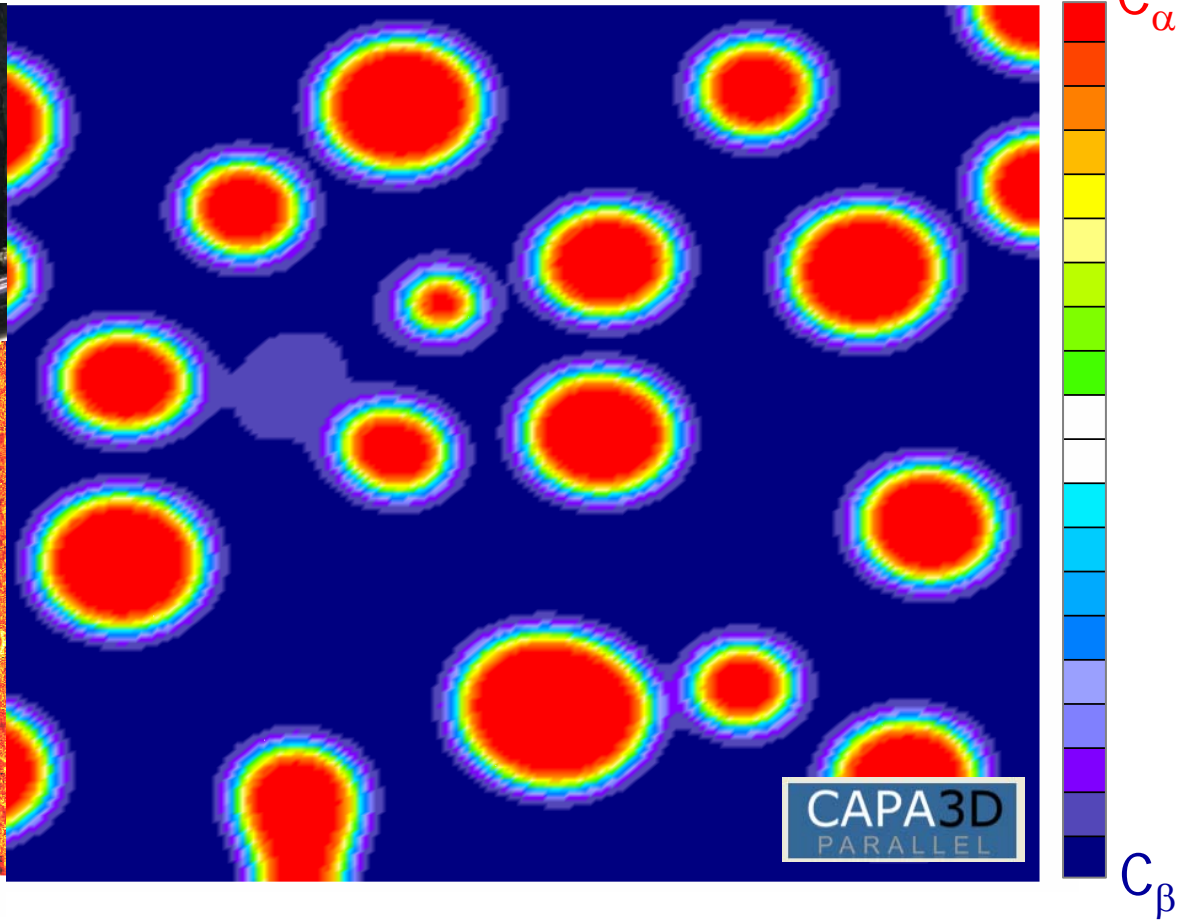
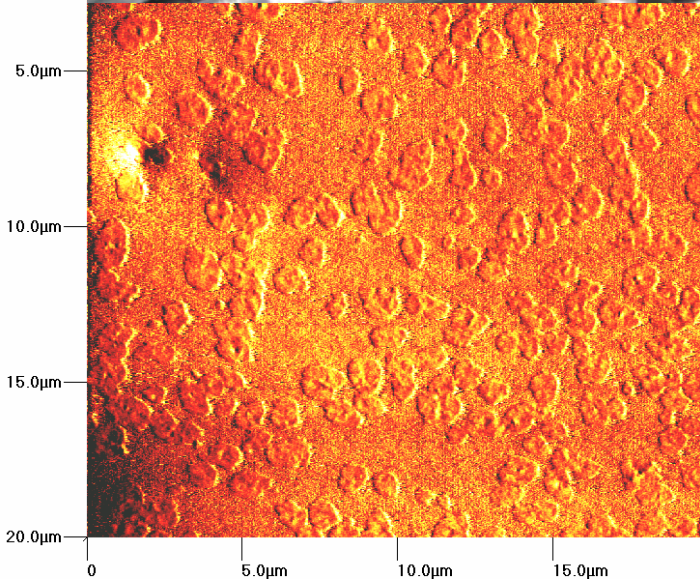
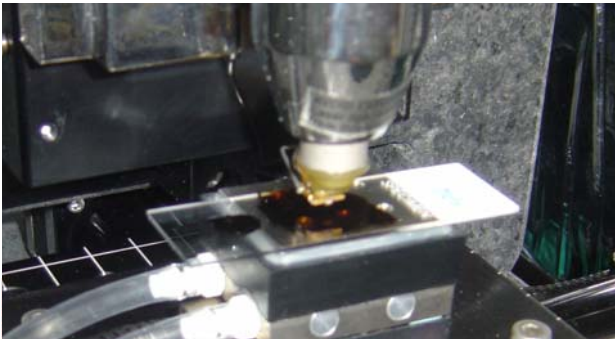
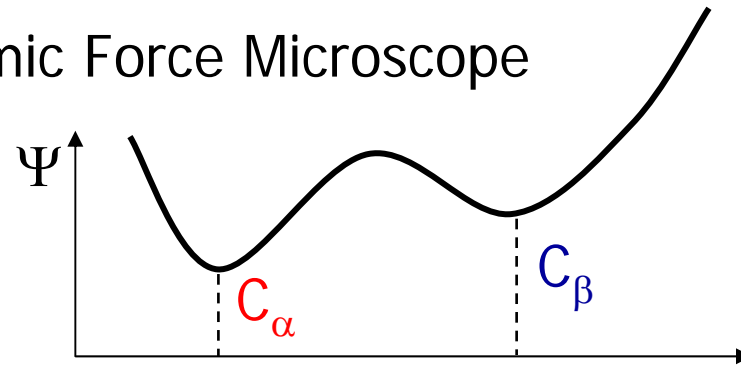
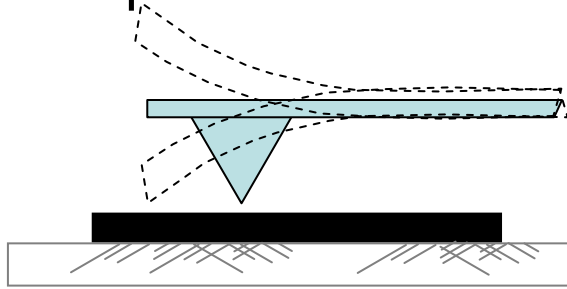

...asphalt under the Atomic Force Microscope

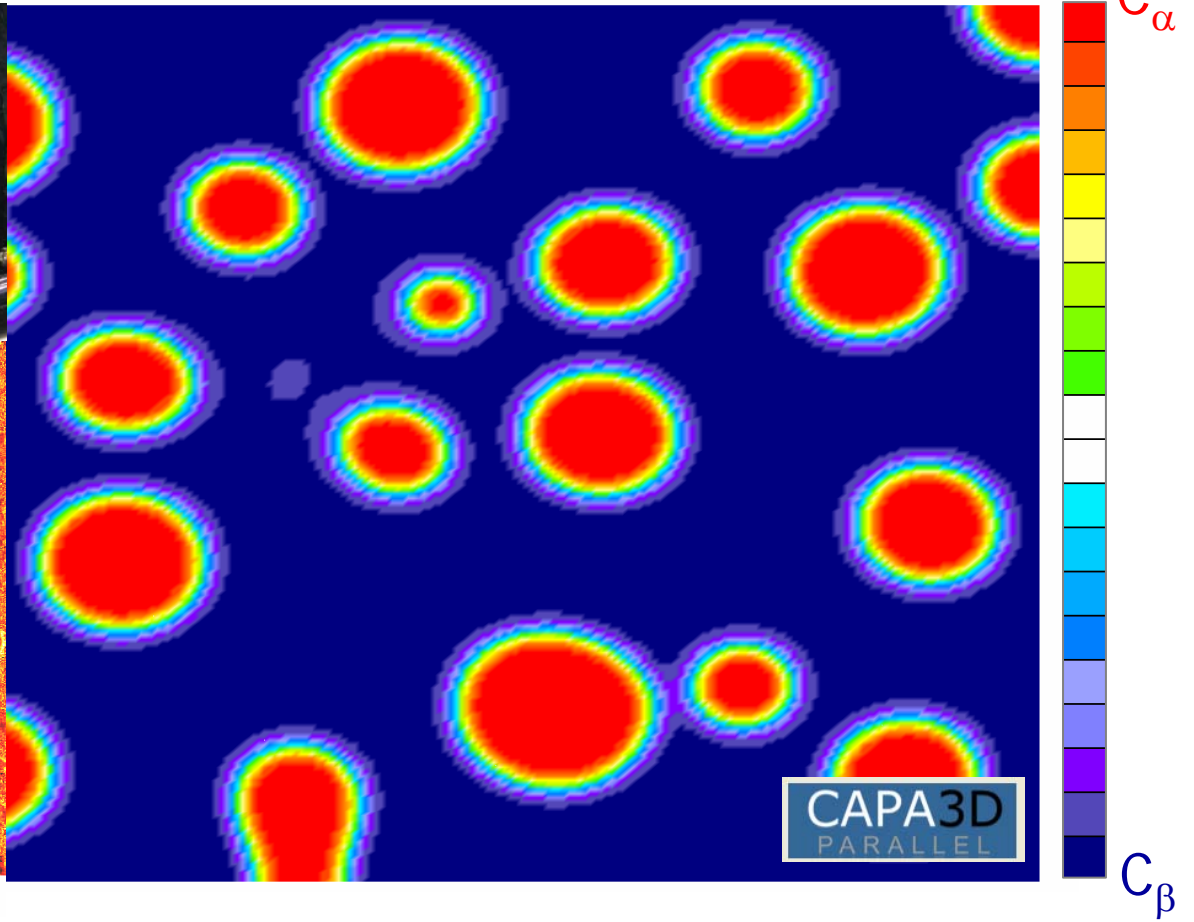
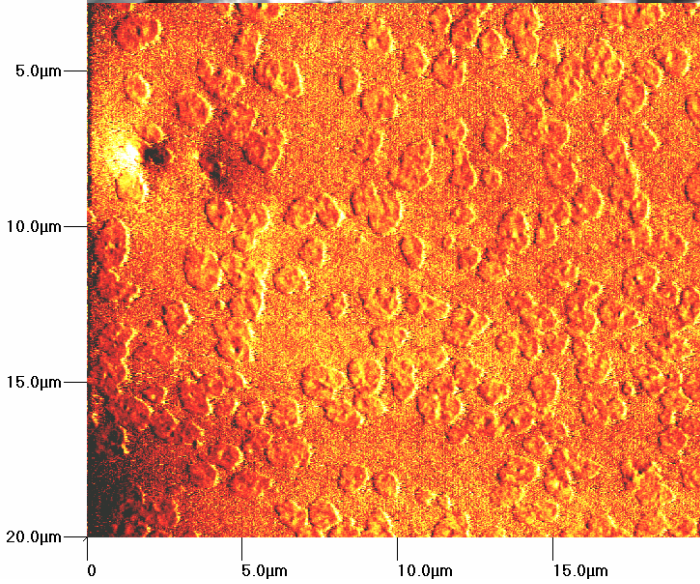
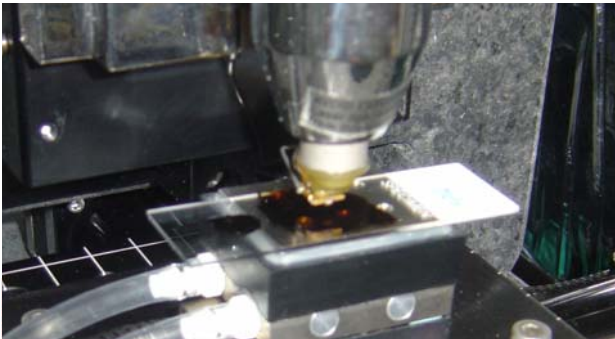
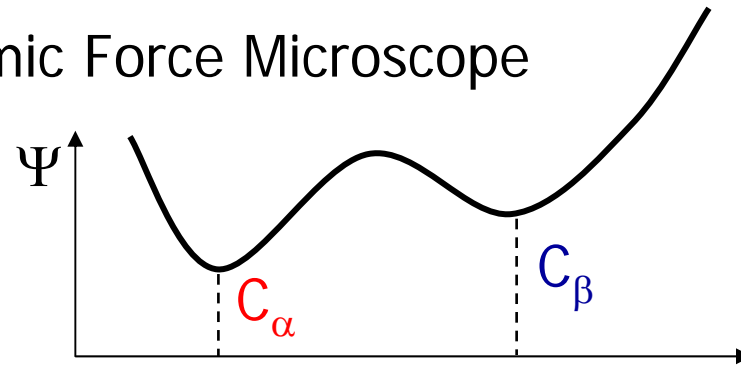
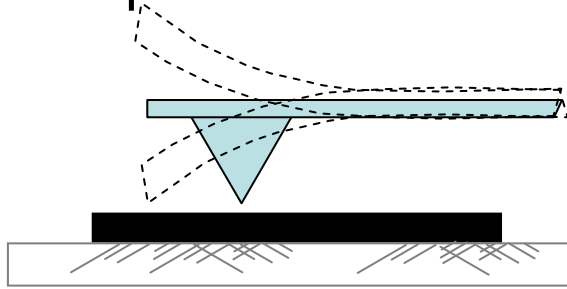

...asphalt under the Atomic Force Microscope

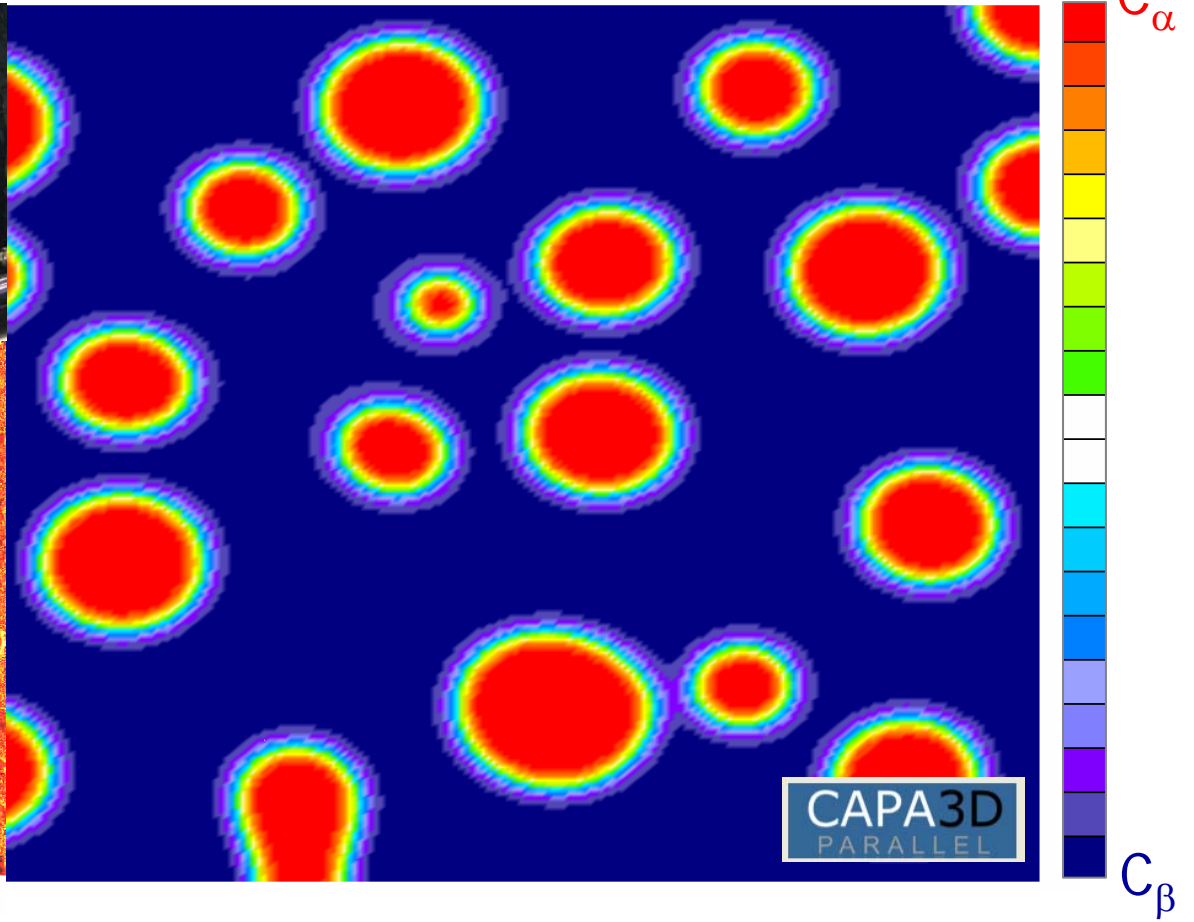
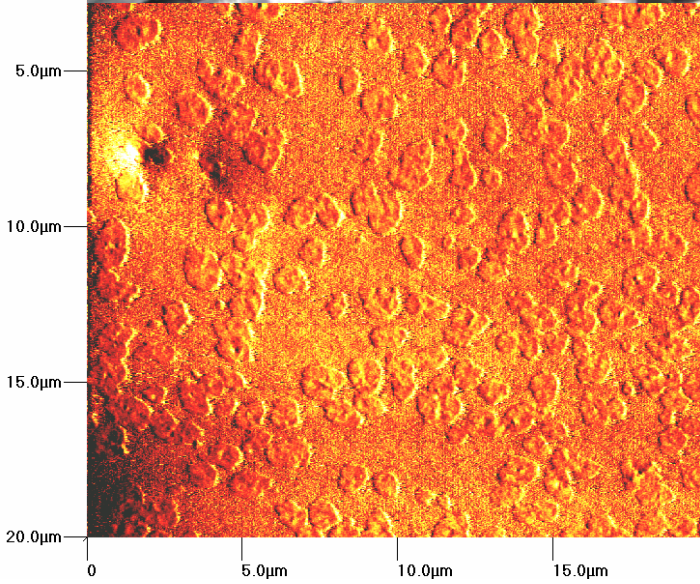
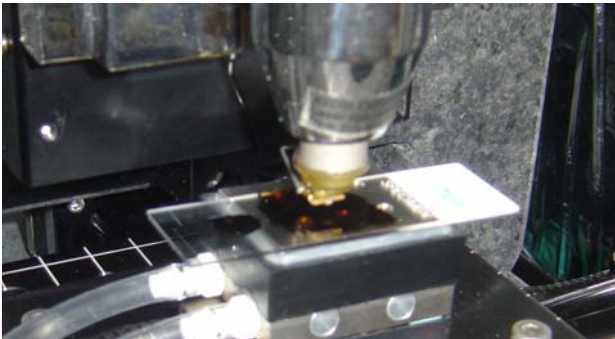
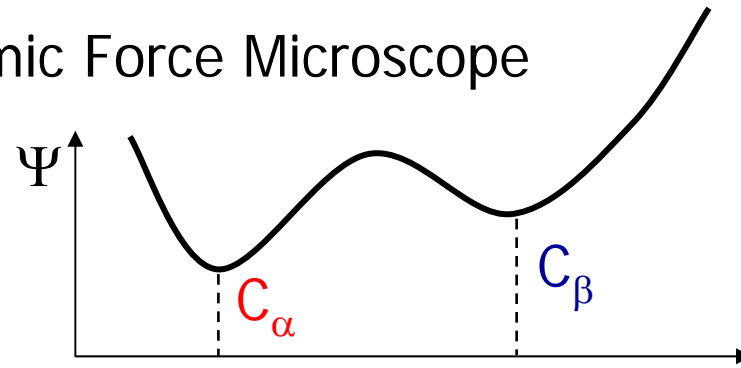
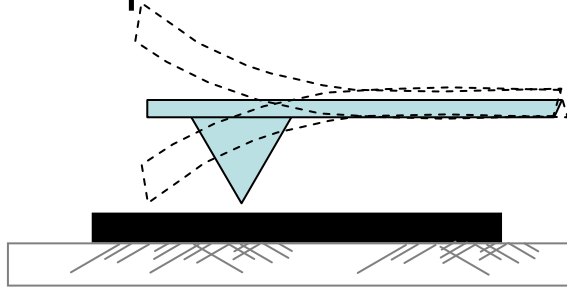

...asphalt under the Atomic Force Microscope

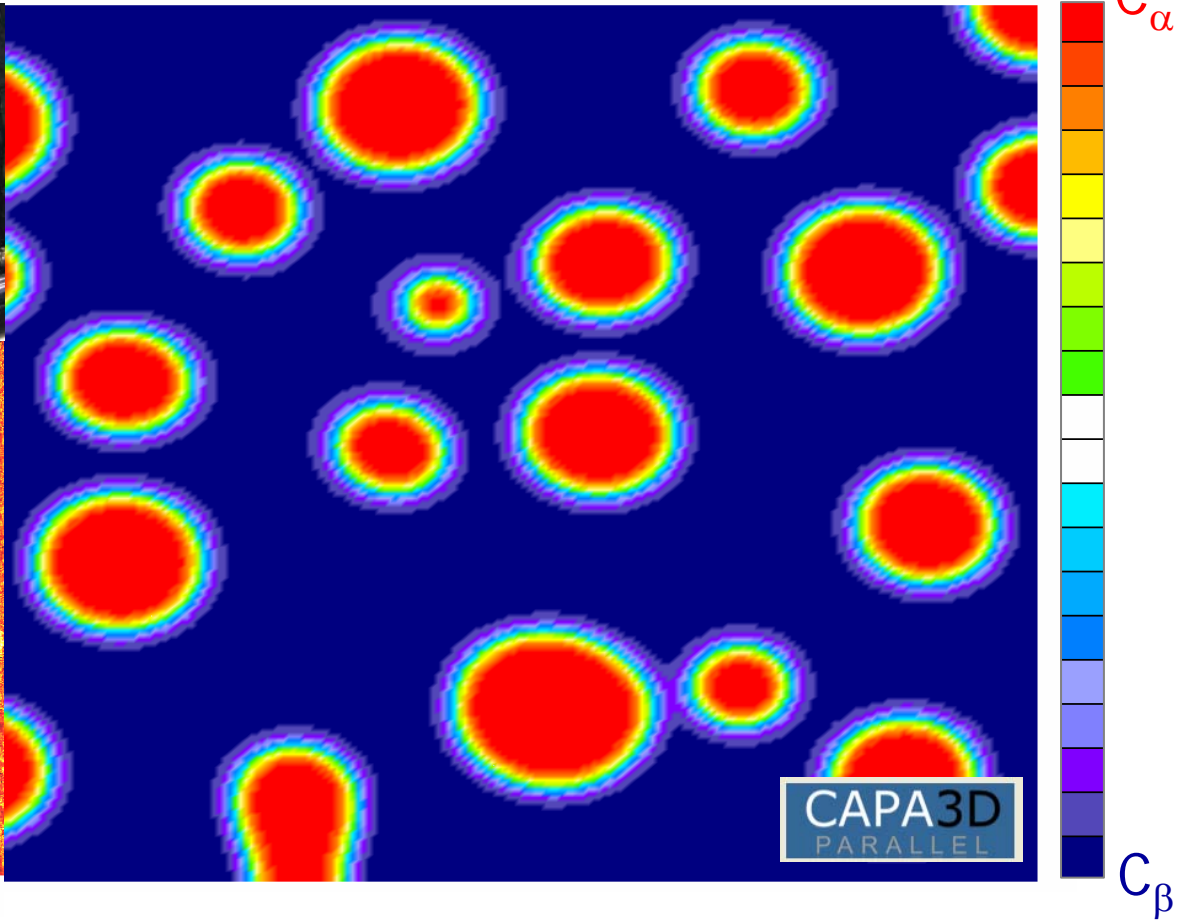
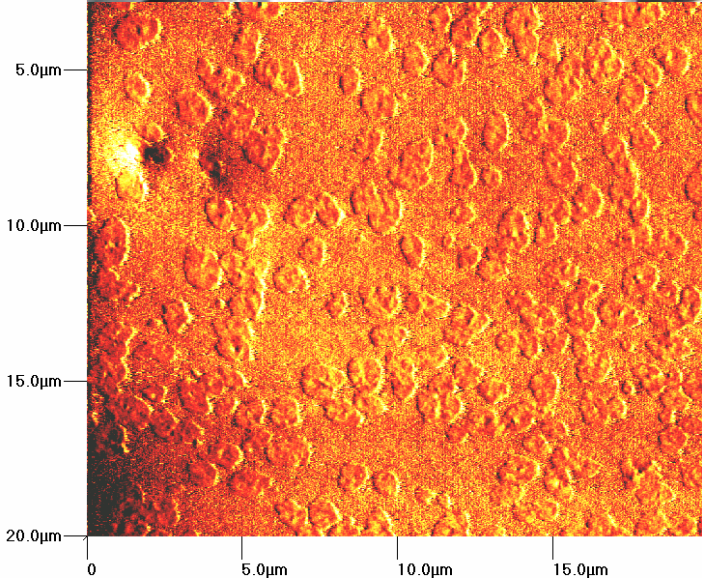
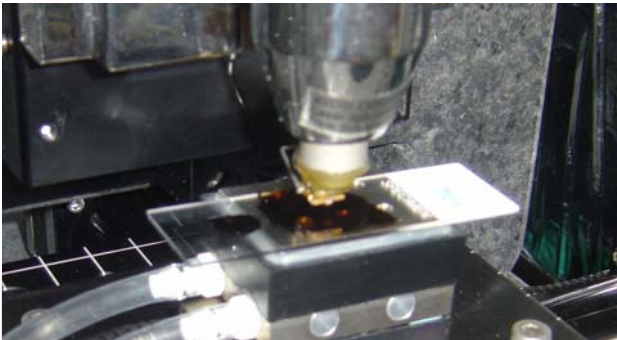
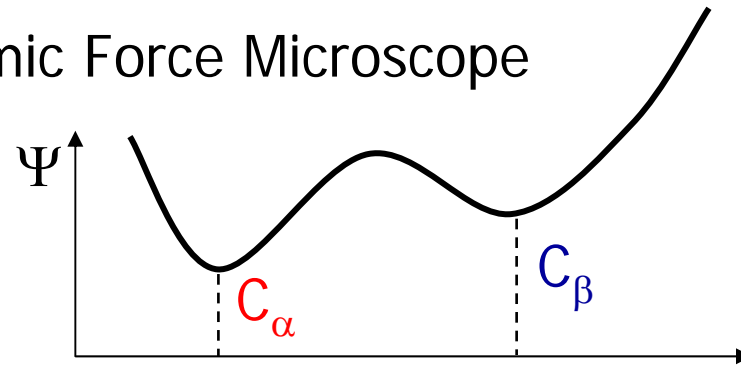
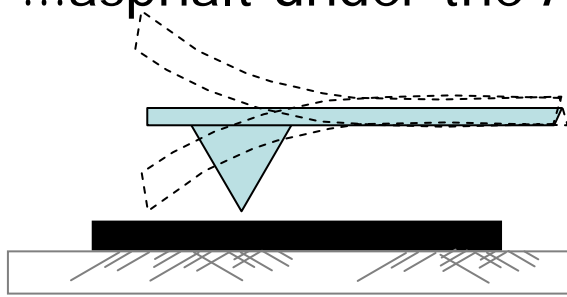

...asphalt under the Atomic Force Microscope

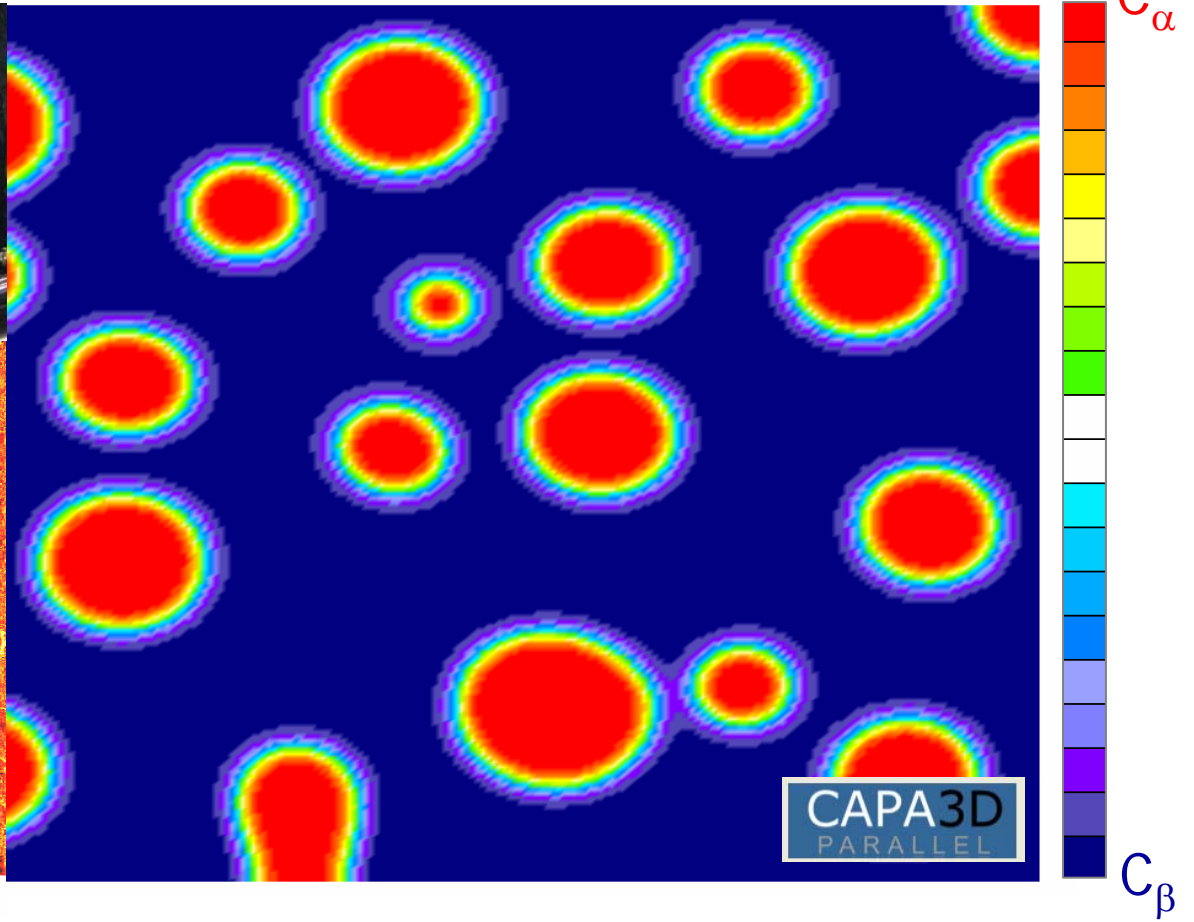
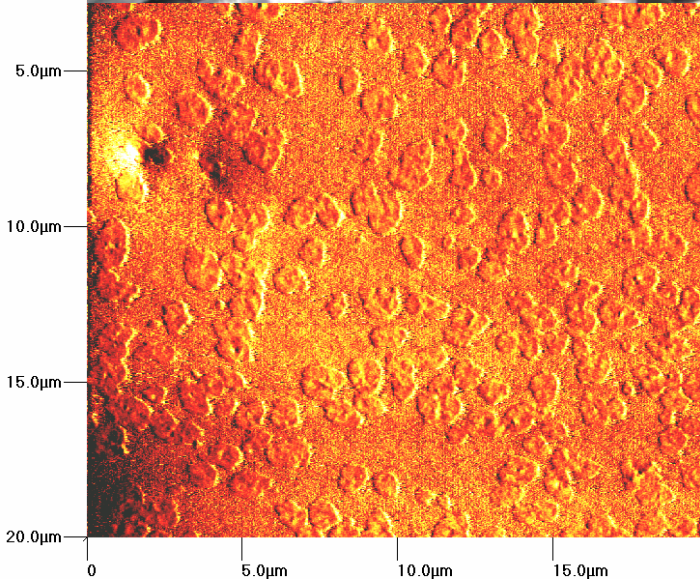
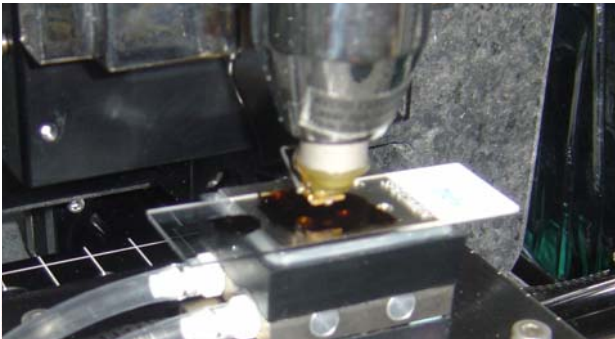
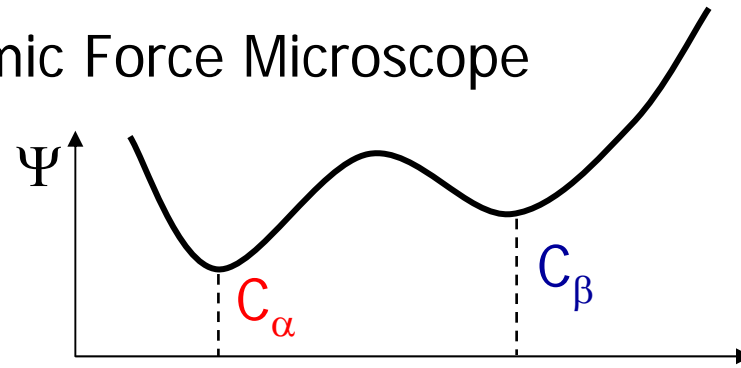
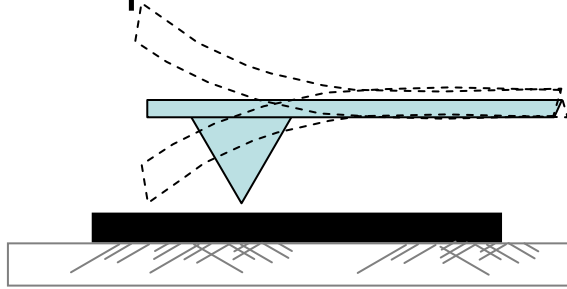

...asphalt under the Atomic Force Microscope

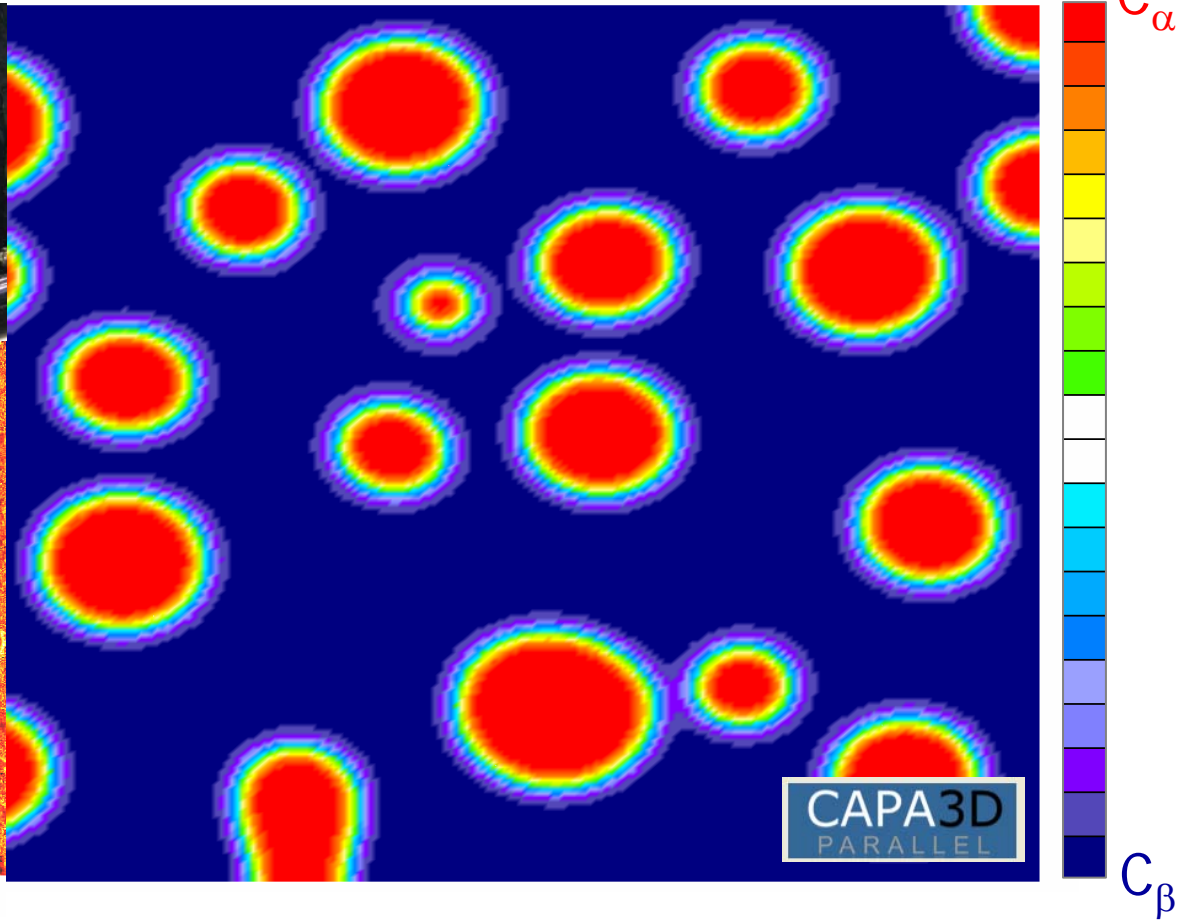
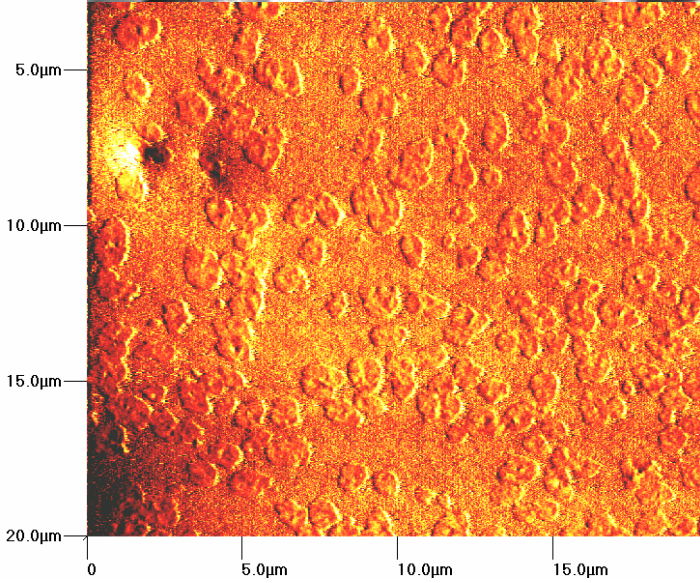
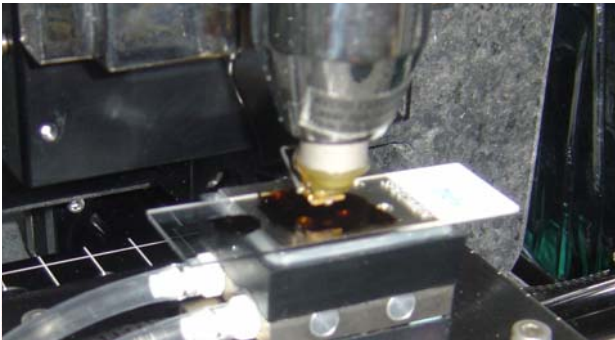
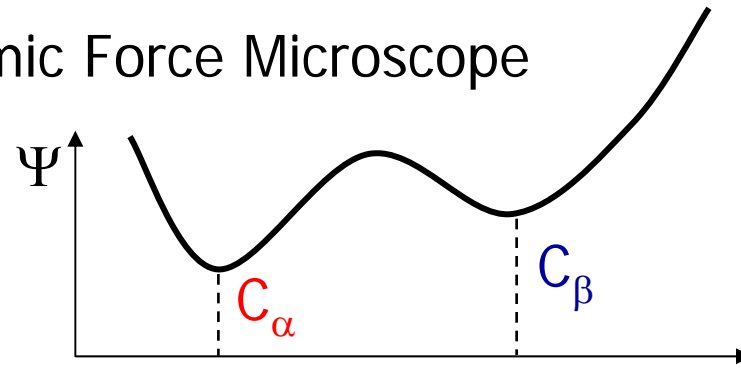
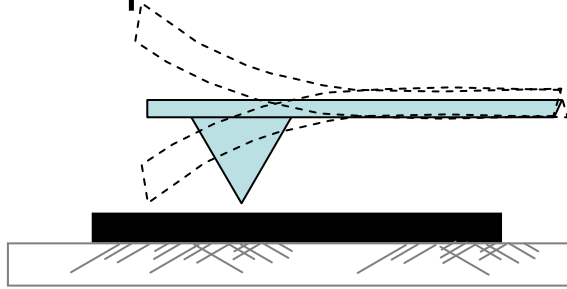

...asphalt under the Atomic Force Microscope

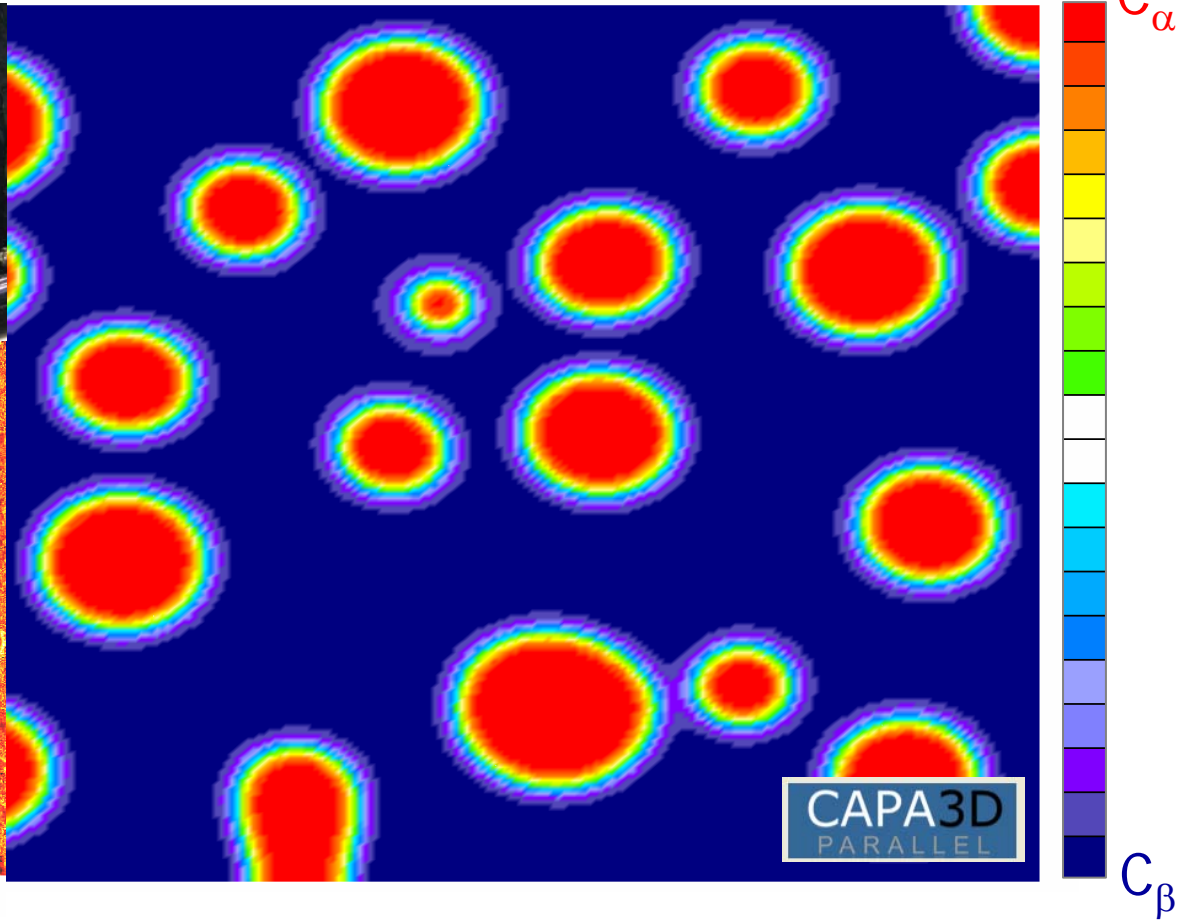
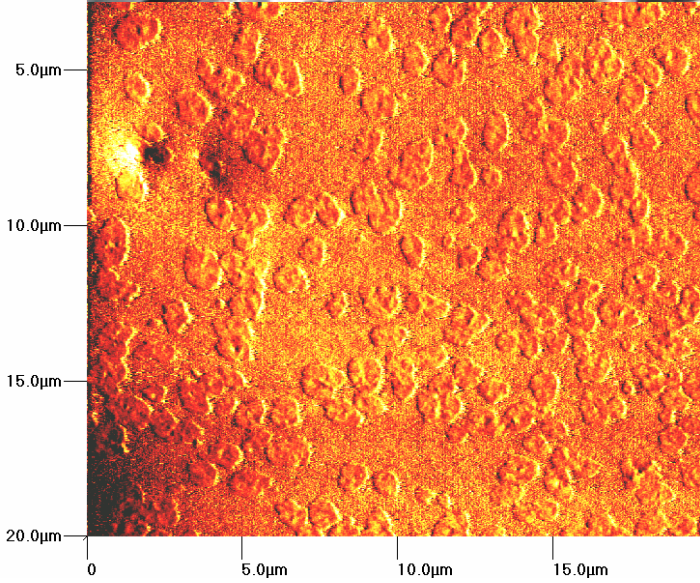
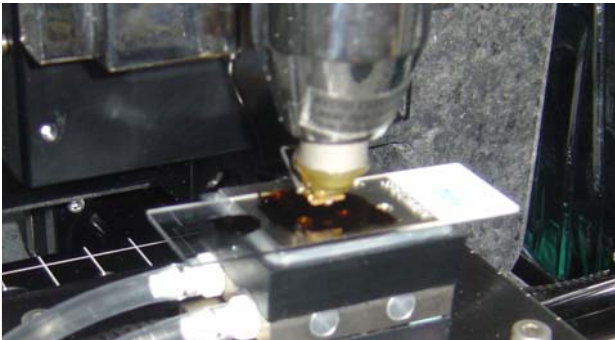
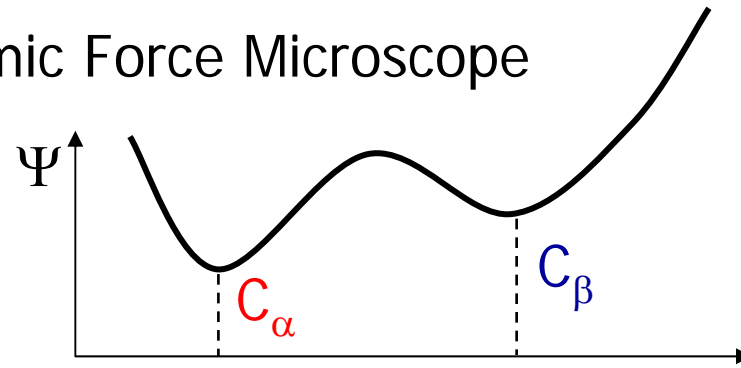
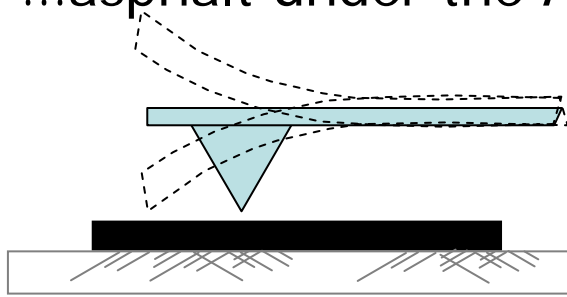

...asphalt under the Atomic Force Microscope

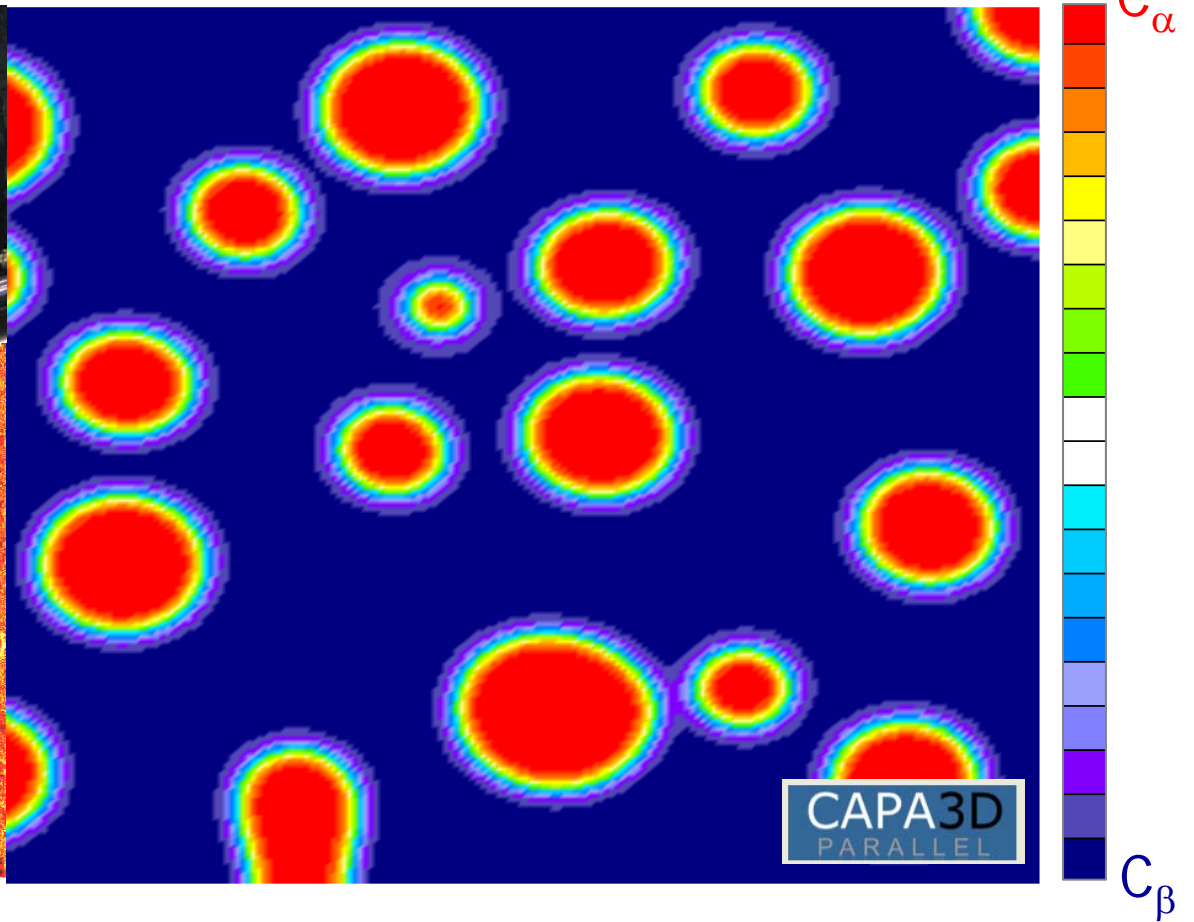
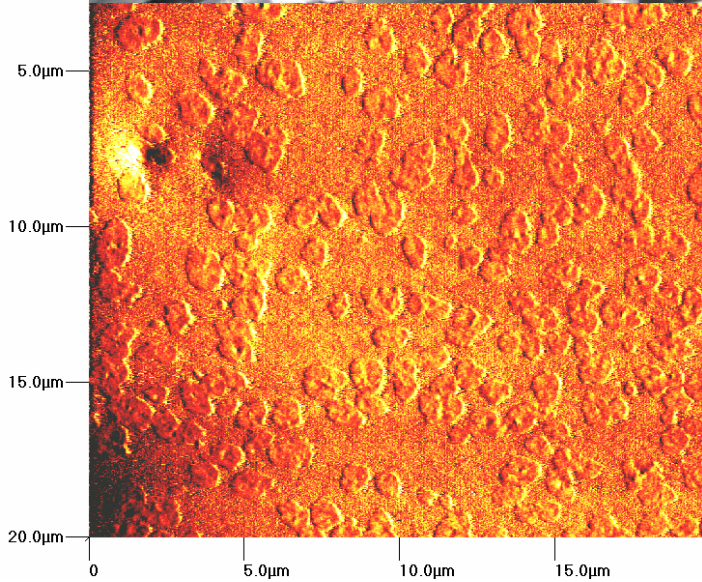
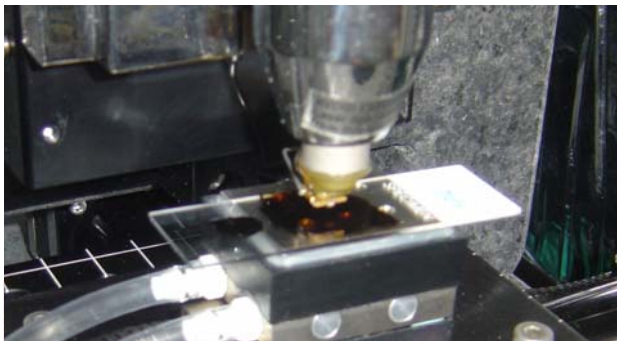
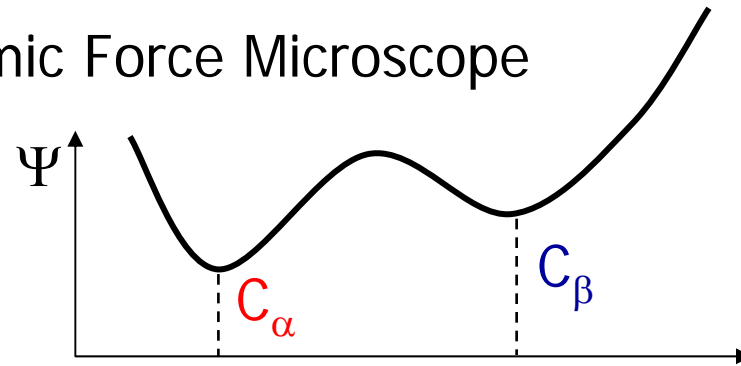
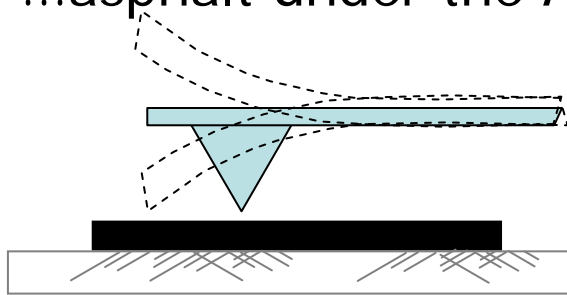

...asphalt under the Atomic Force Microscope

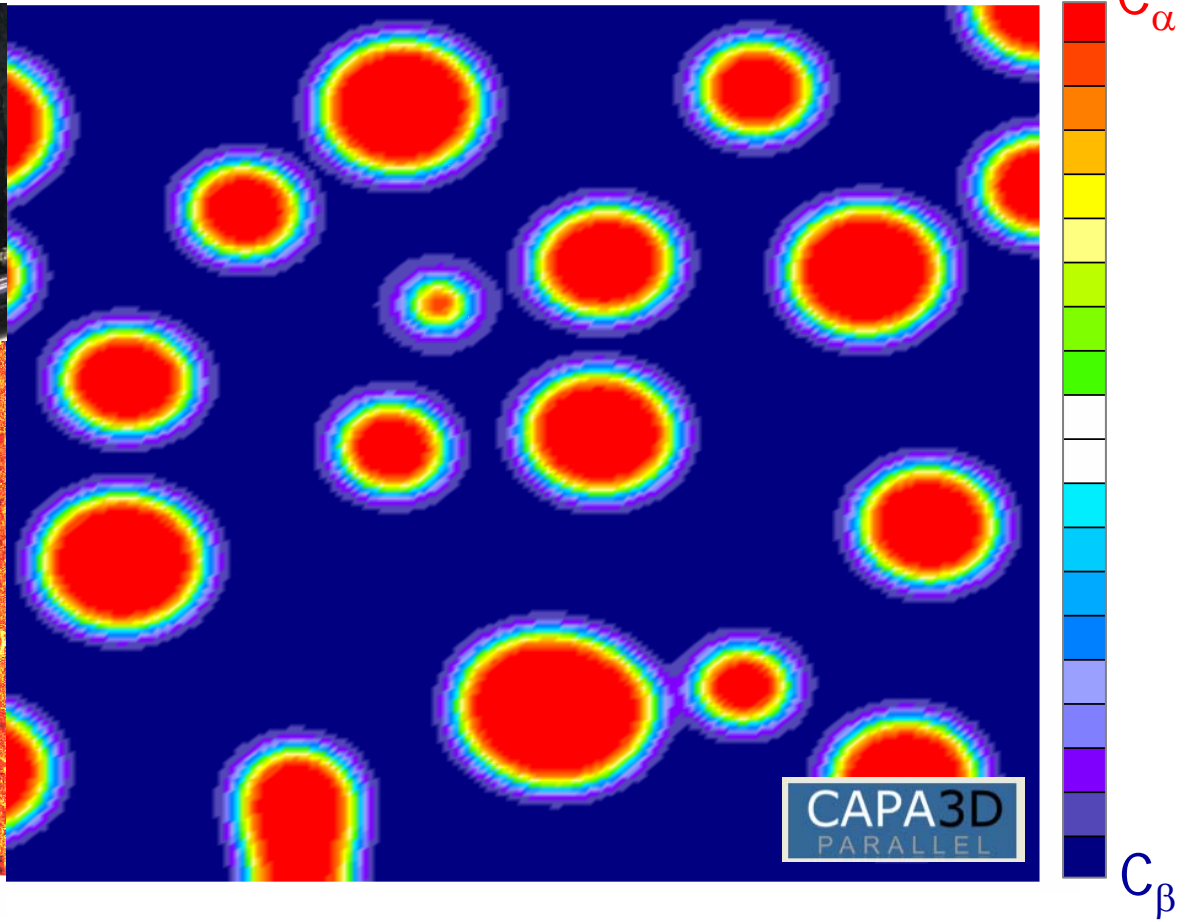
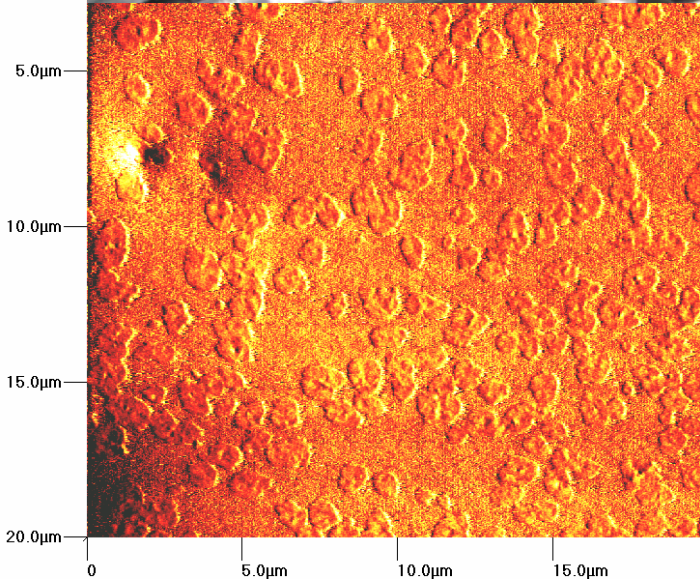
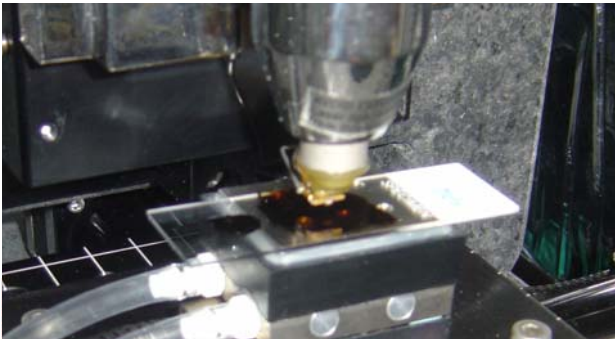
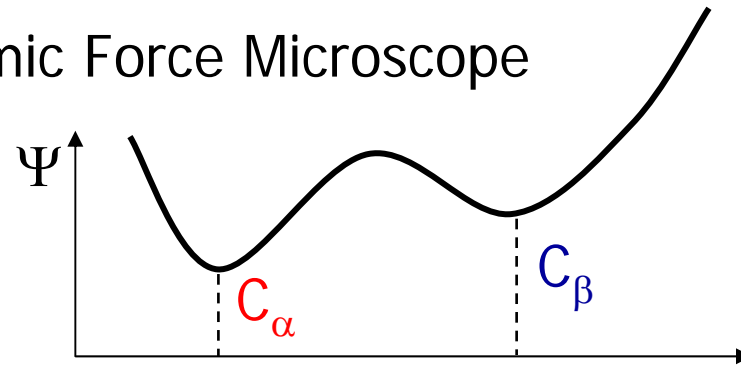
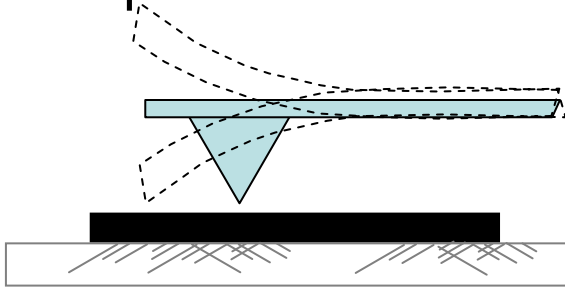

...asphalt under the Atomic Force Microscope

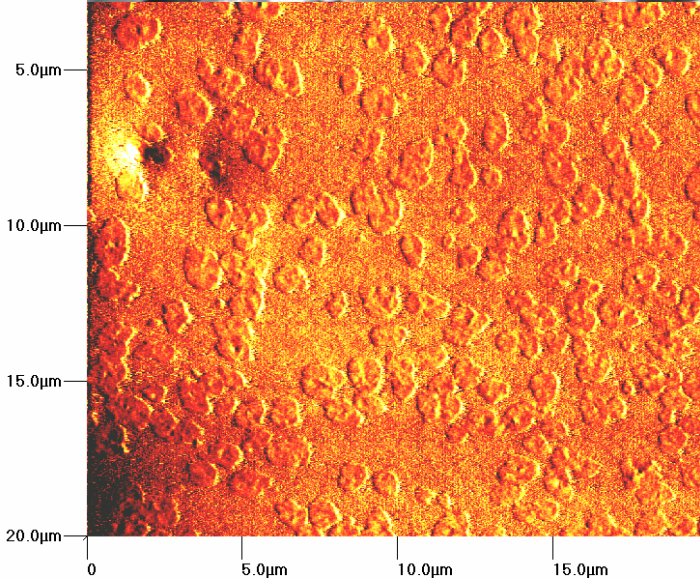
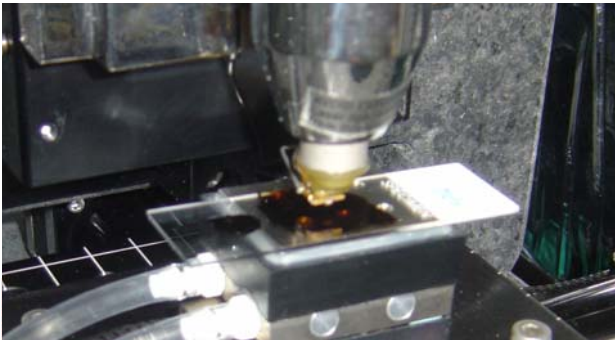
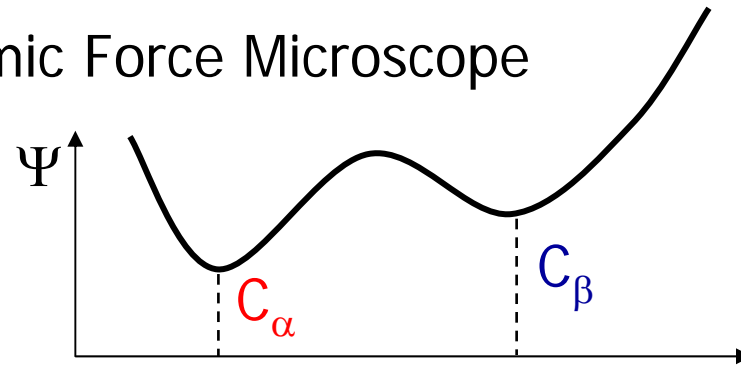
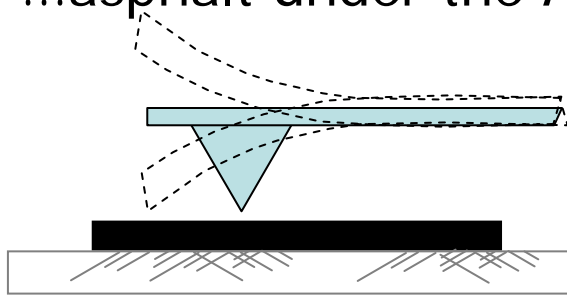

- Phase induced material inhomogeneity

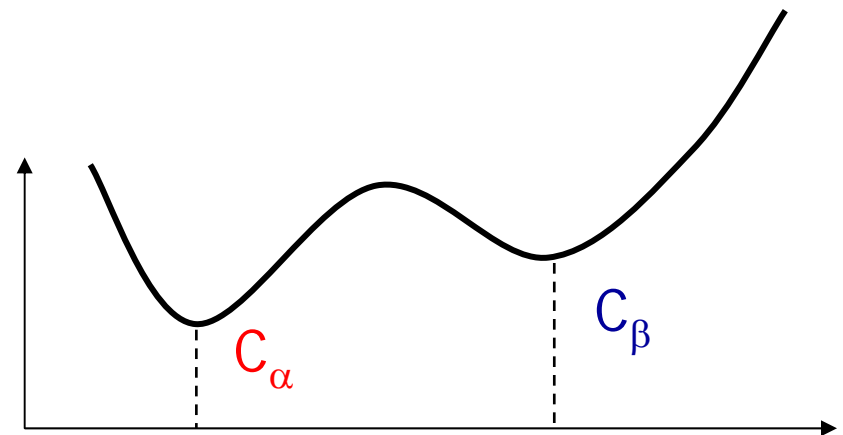
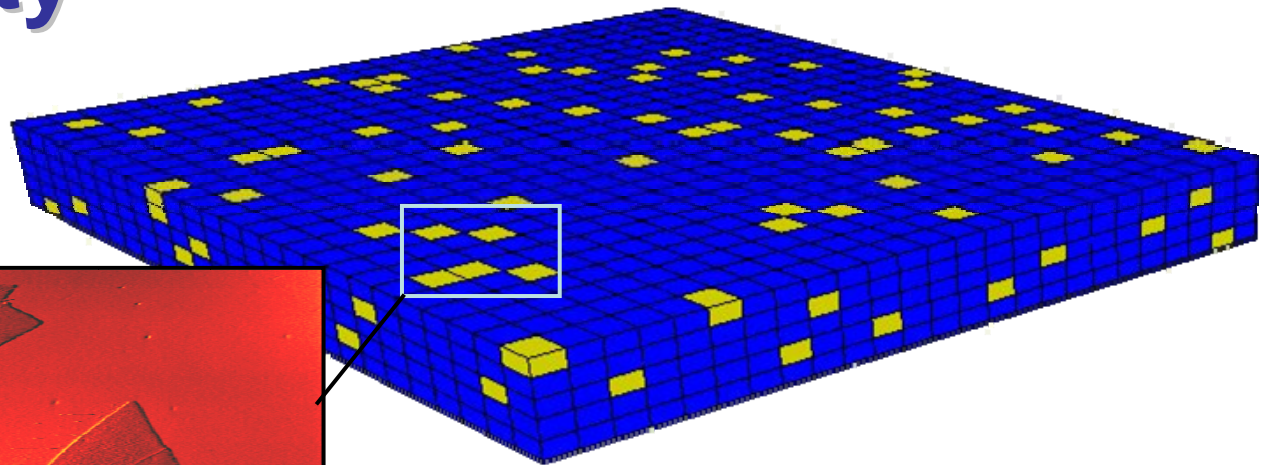
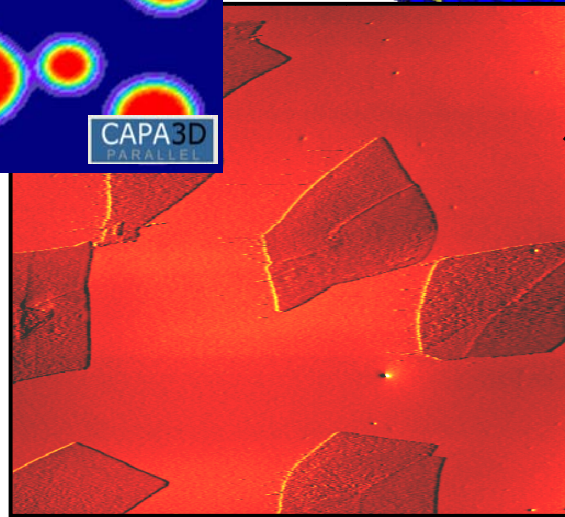
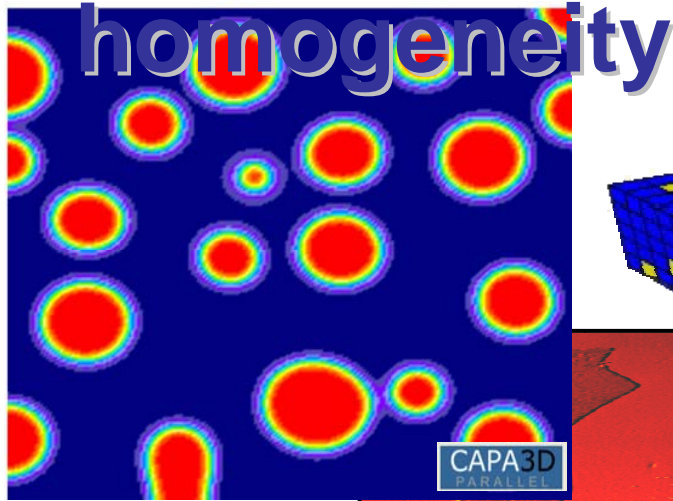

$$\rho_\alpha \frac{DC_\alpha}{Dt} - \text{div}(\rho_\alpha \underline{\underline{M}} \cdot \nabla \mu_\alpha) = 0$$

Micro-scale mechanical testing of homogeneous specimen

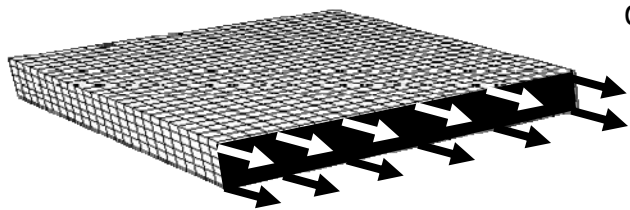
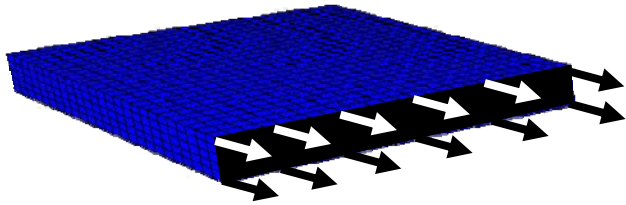

displacements
CAPA3D

normal stresses
CAPA3D

Micro-scale mechanical testing of homogeneous specimen

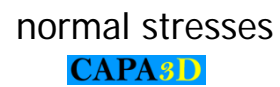
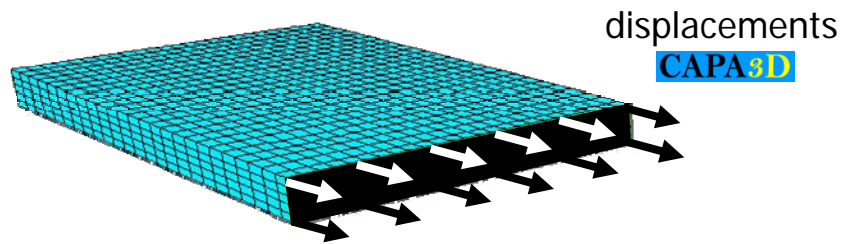
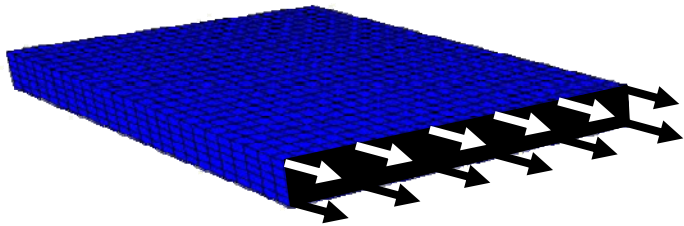

Micro-scale mechanical testing of homogeneous specimen

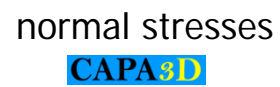
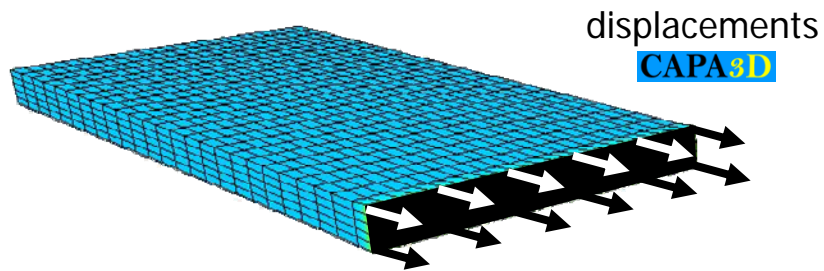
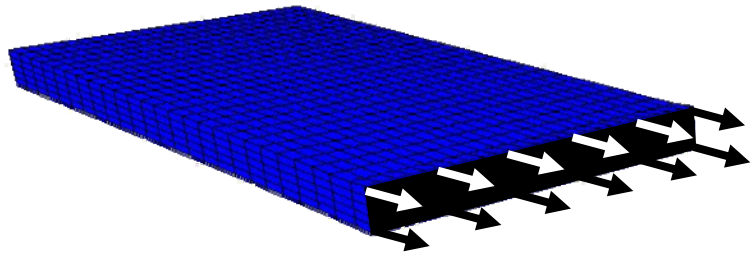

Micro-scale mechanical testing of homogeneous specimen

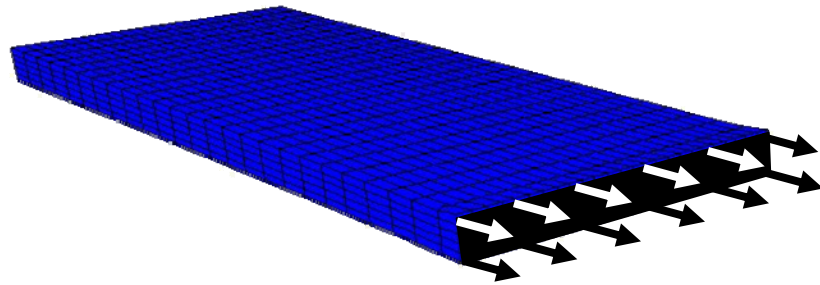

displacements

CAPA3D

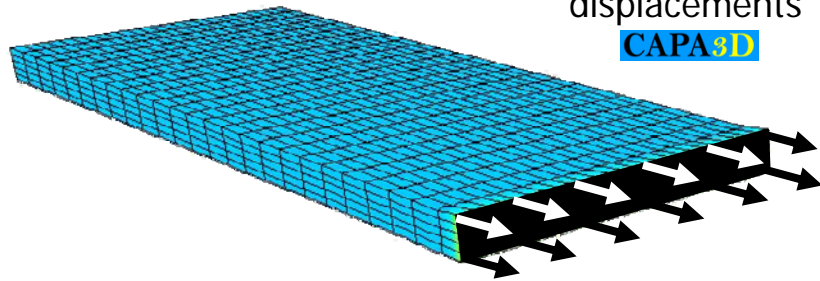

normal stresses

CAPA3D

Micro-scale mechanical testing of homogeneous specimen

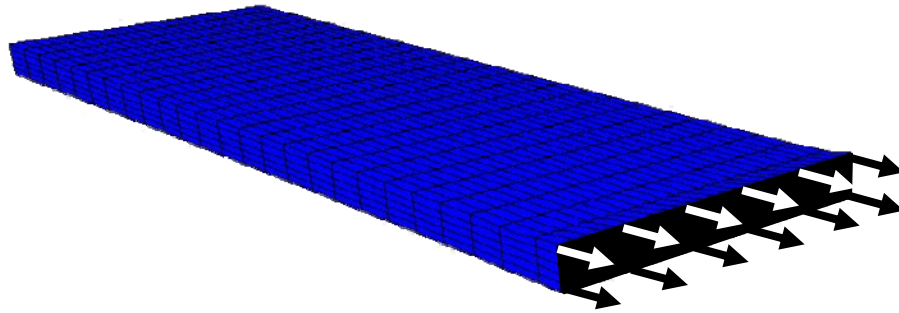

displacements

CAPA3D

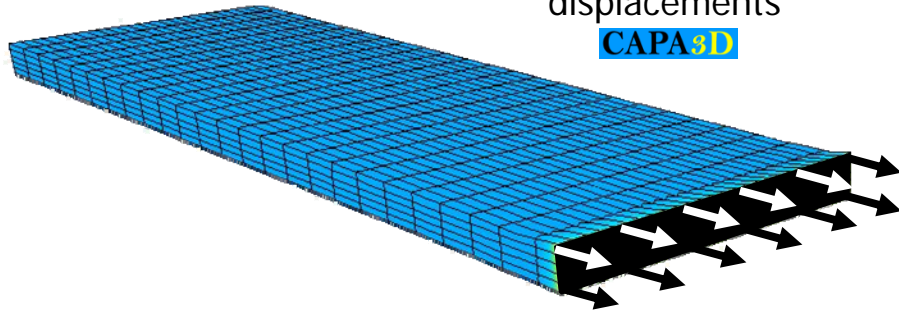

normal stresses

CAPA3D

Micro-scale mechanical testing of homogeneous specimen

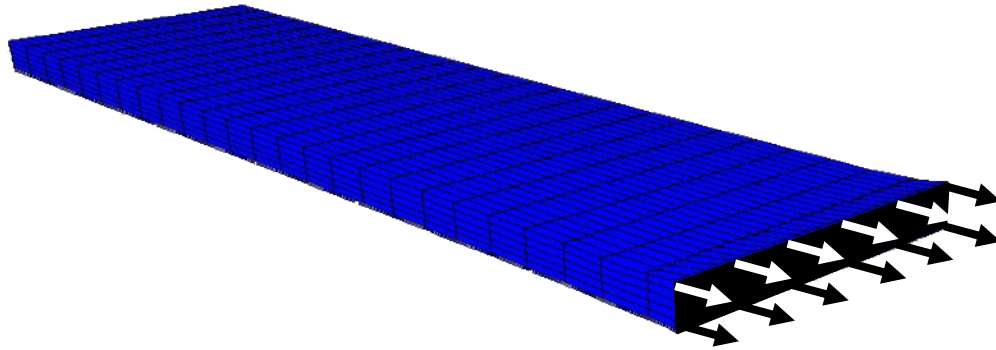

displacements

CAPA3D

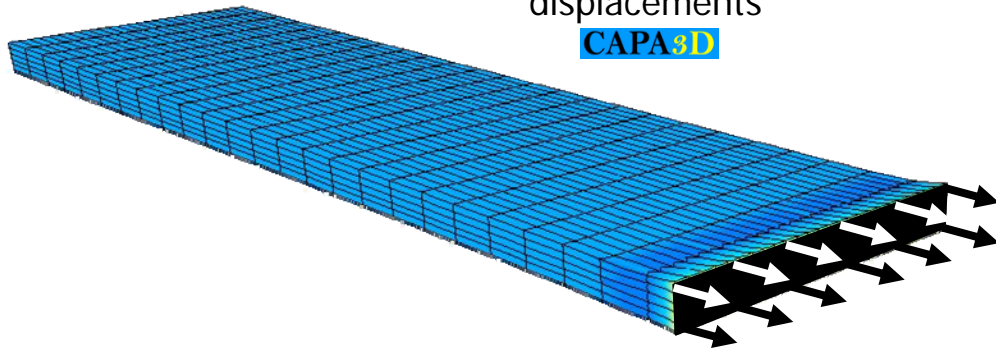

normal stresses

CAPA3D

Micro-scale mechanical testing of homogeneous specimen

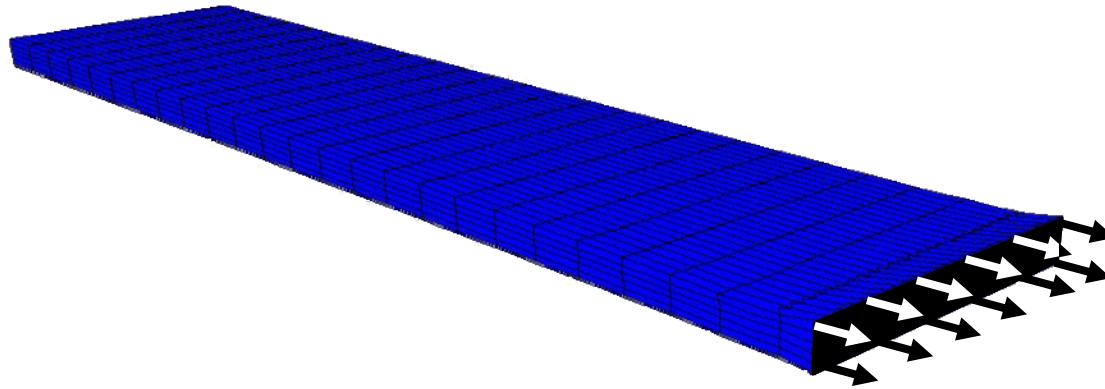

displacements

CAPA3D

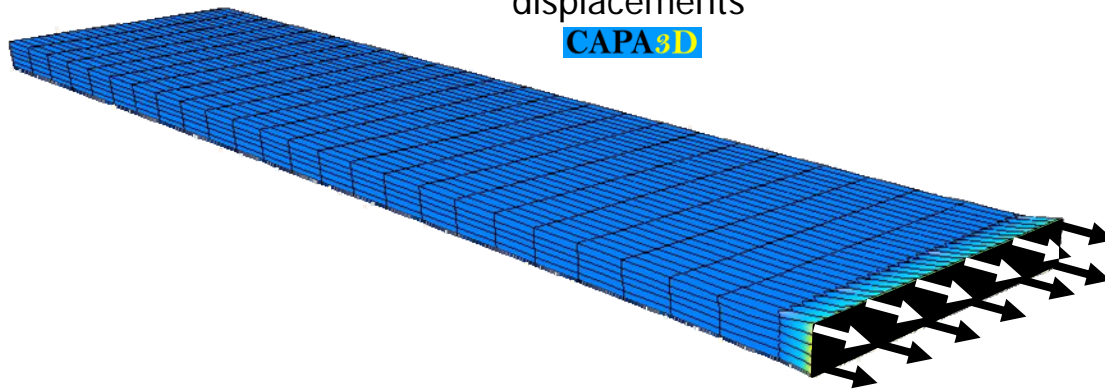

normal stresses

CAPA3D

Micro-scale mechanical testing of homogeneous specimen

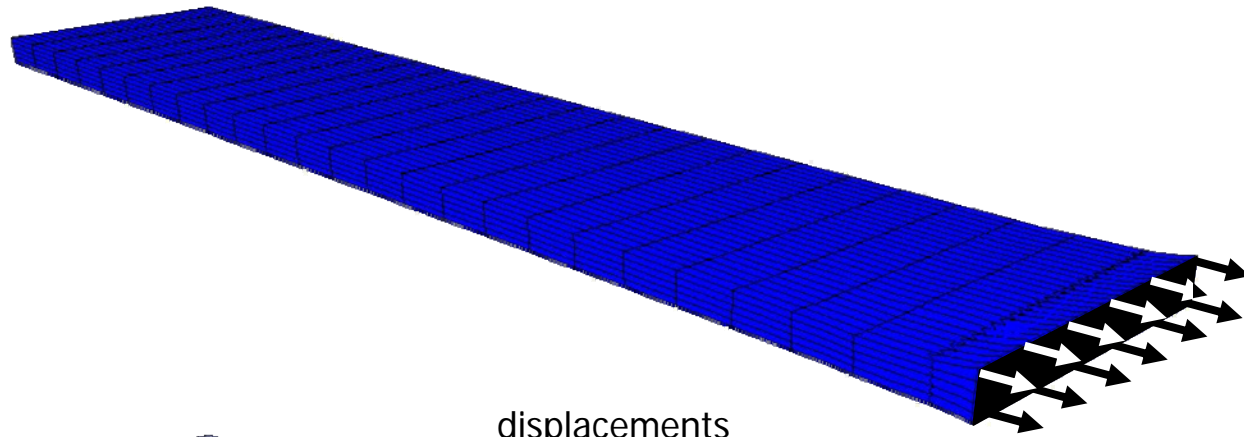

displacements
CAPA3D

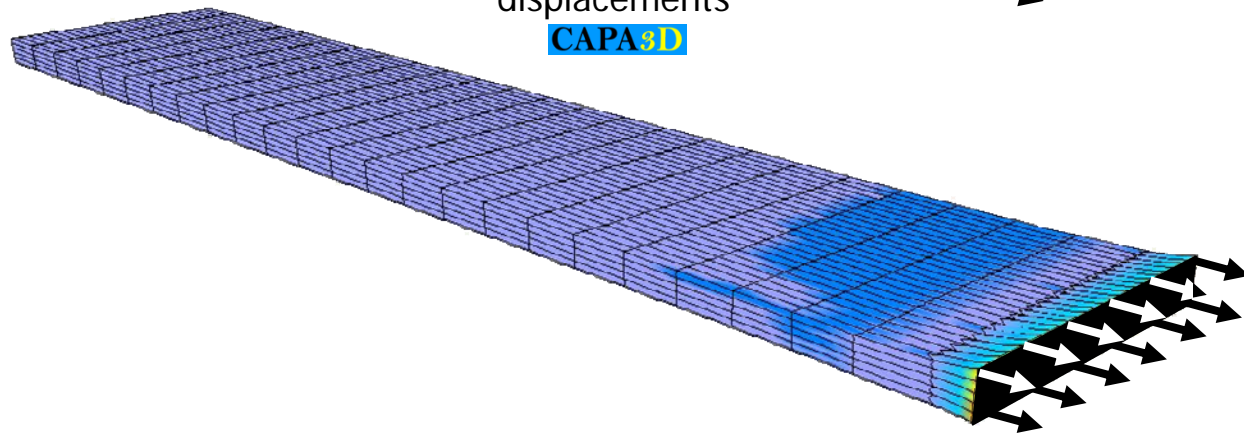

normal stresses
CAPA3D

Micro-scale mechanical testing of homogeneous specimen

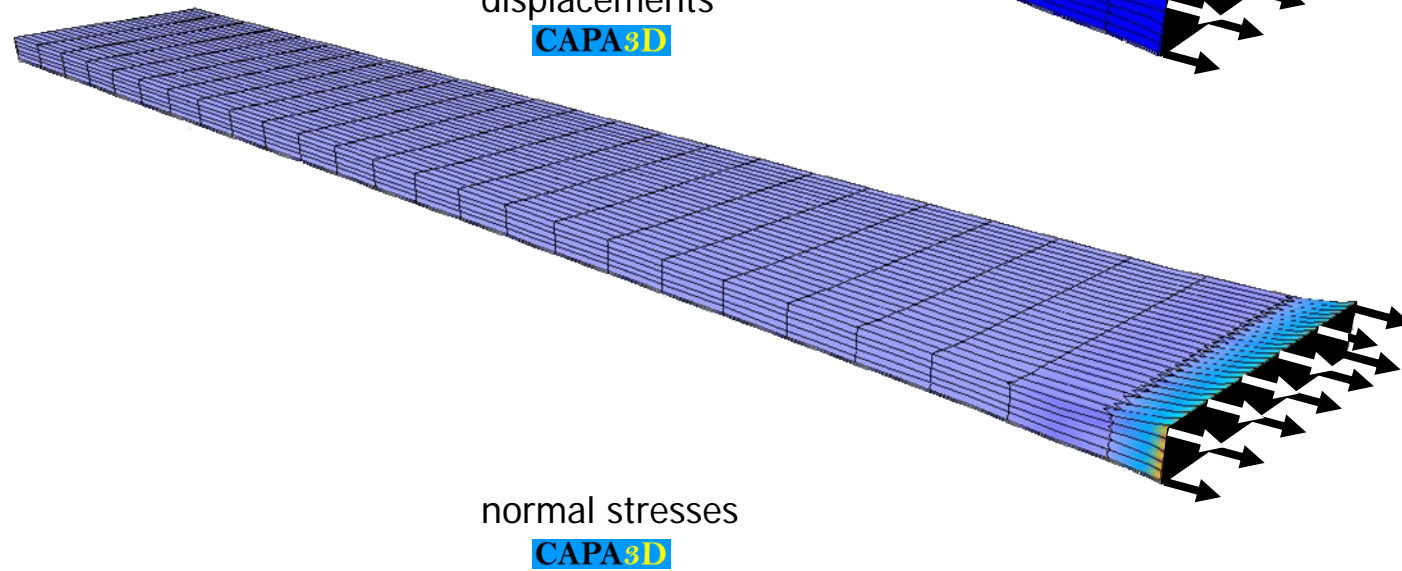
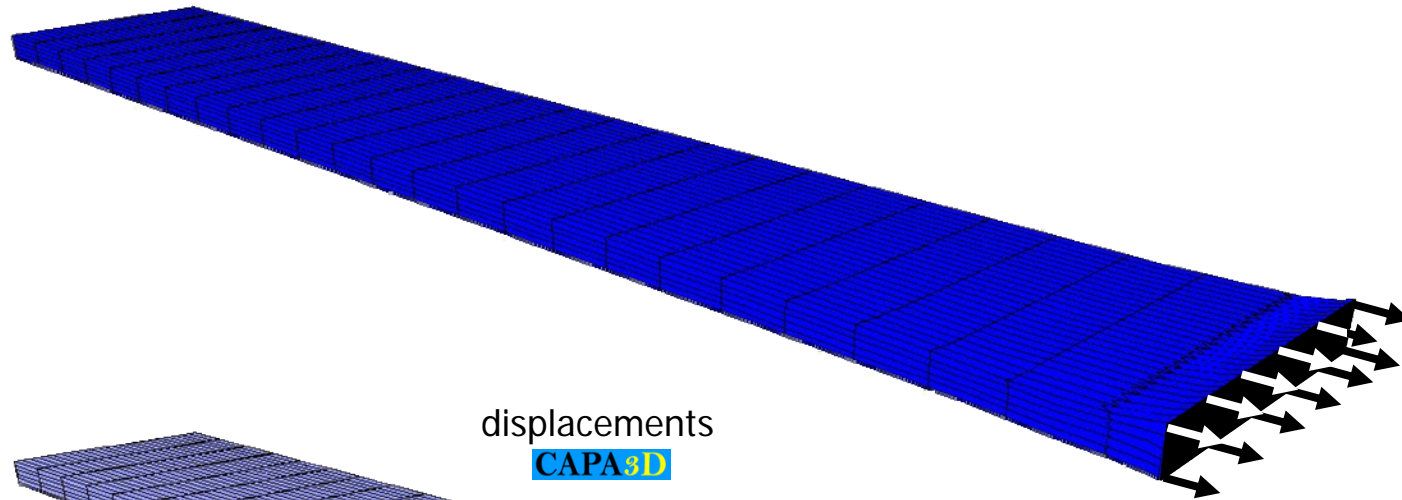

Micro-scale mechanical testing of **inhomogeneous** specimen

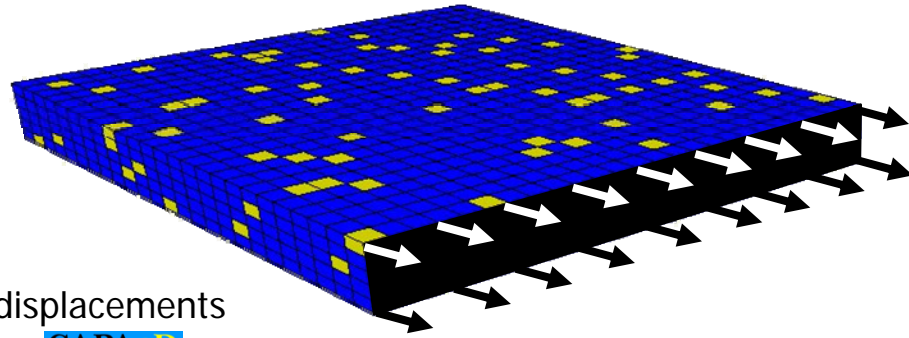

displacements

CAPA3D

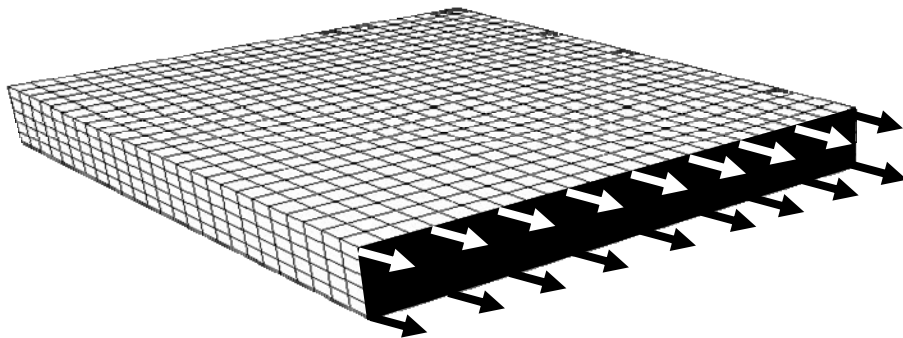

normal stresses

CAPA3D

Micro-scale mechanical testing of **inhomogeneous** specimen

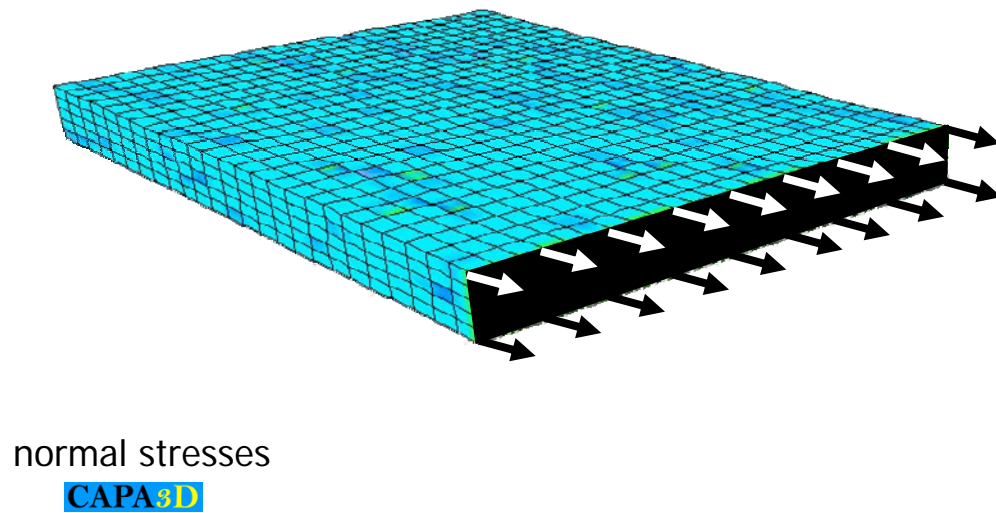
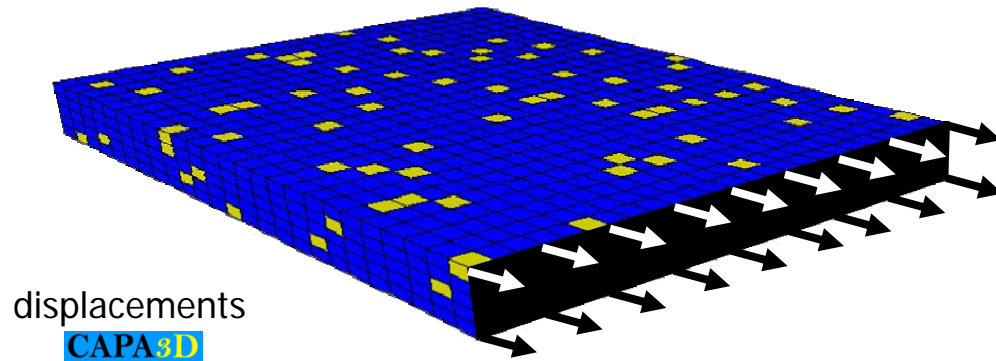

Micro-scale mechanical testing of **inhomogeneous** specimen

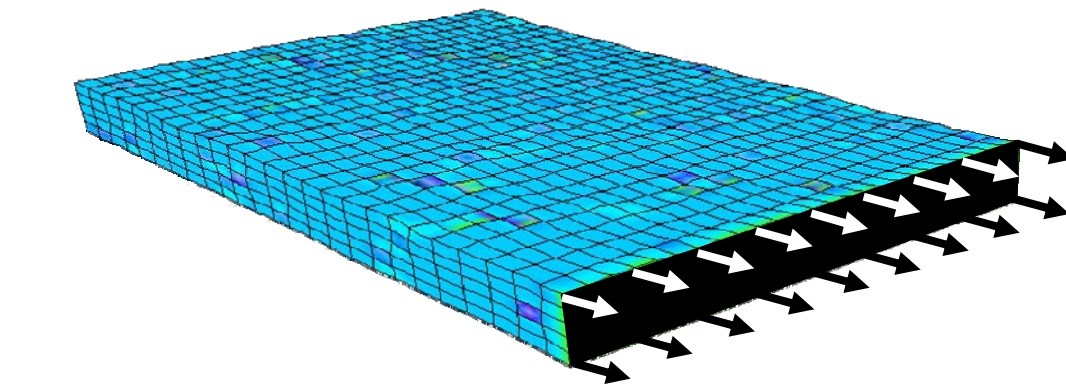
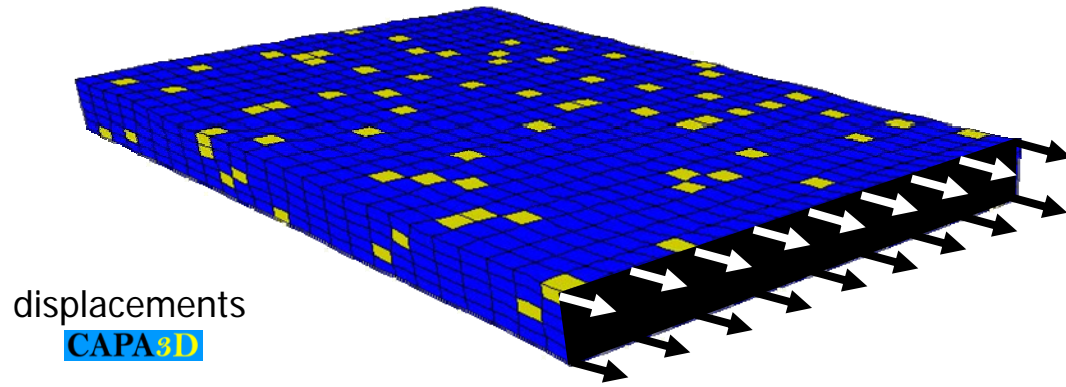

Micro-scale mechanical testing of **inhomogeneous** specimen

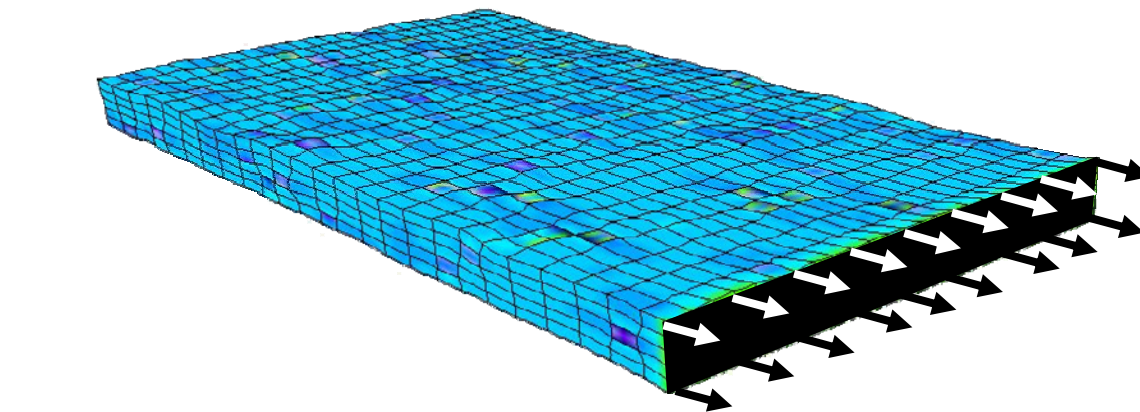
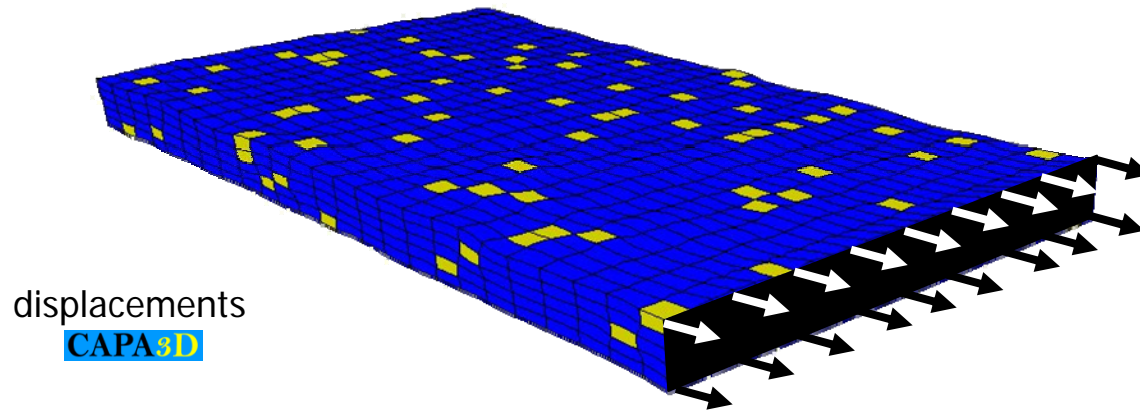

Micro-scale mechanical testing of **inhomogeneous** specimen

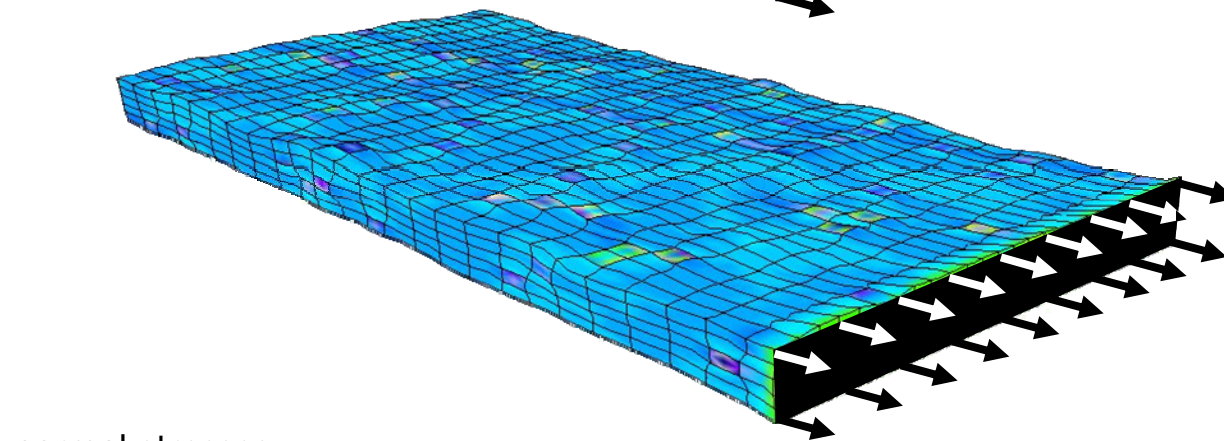
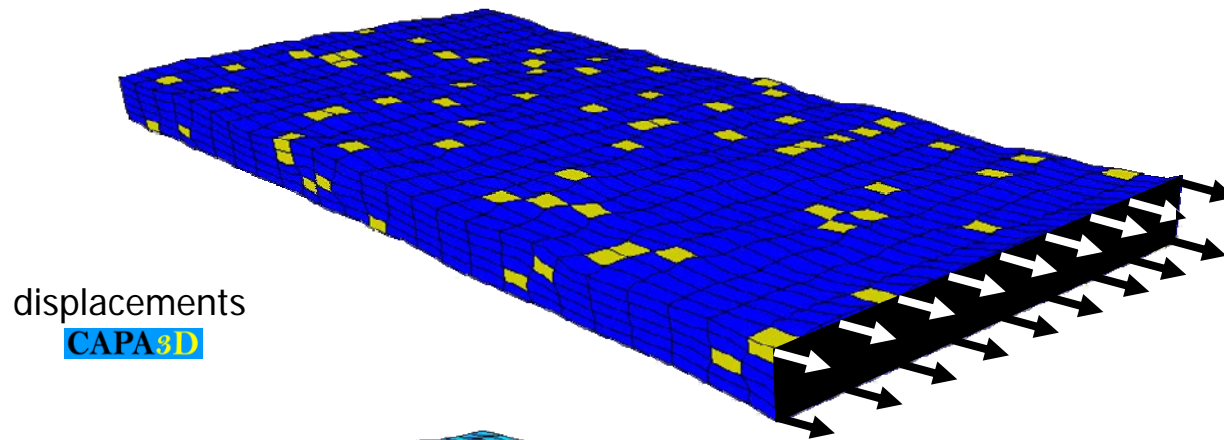

Micro-scale mechanical testing of **inhomogeneous** specimen

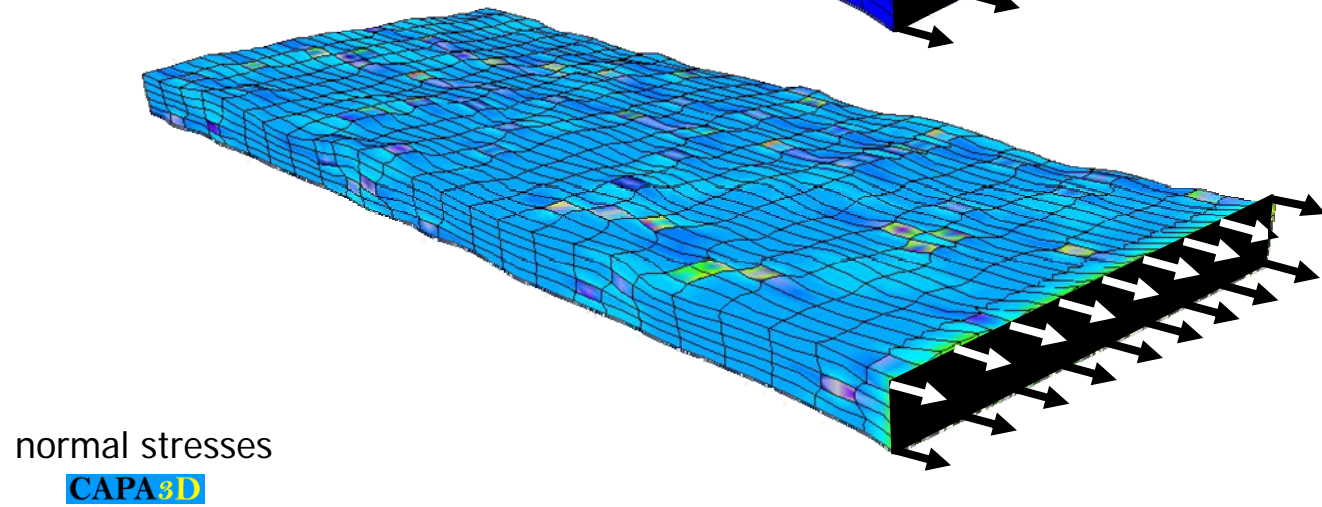
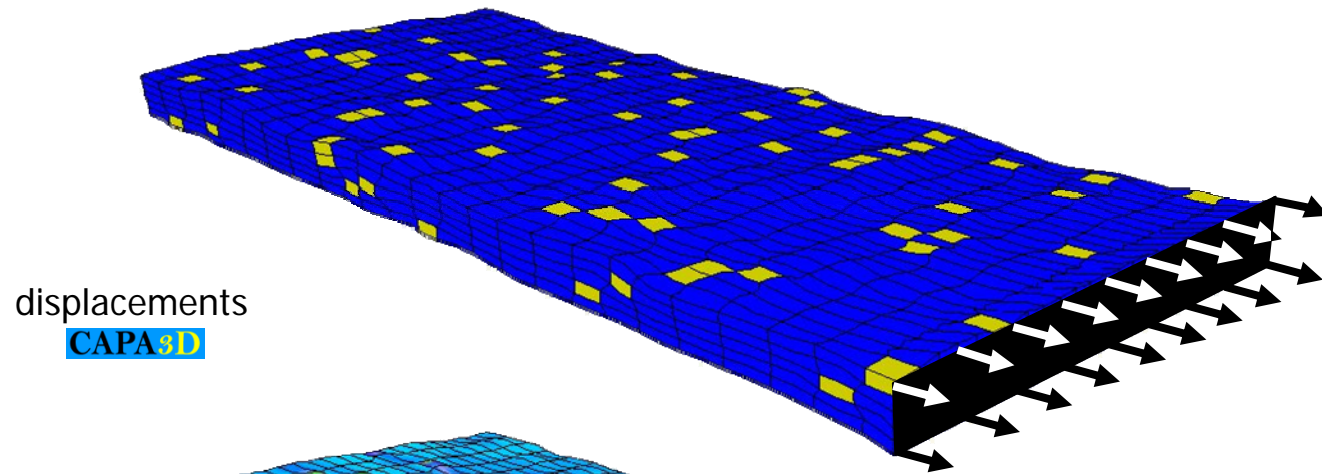

Micro-scale mechanical testing of **inhomogeneous** specimen

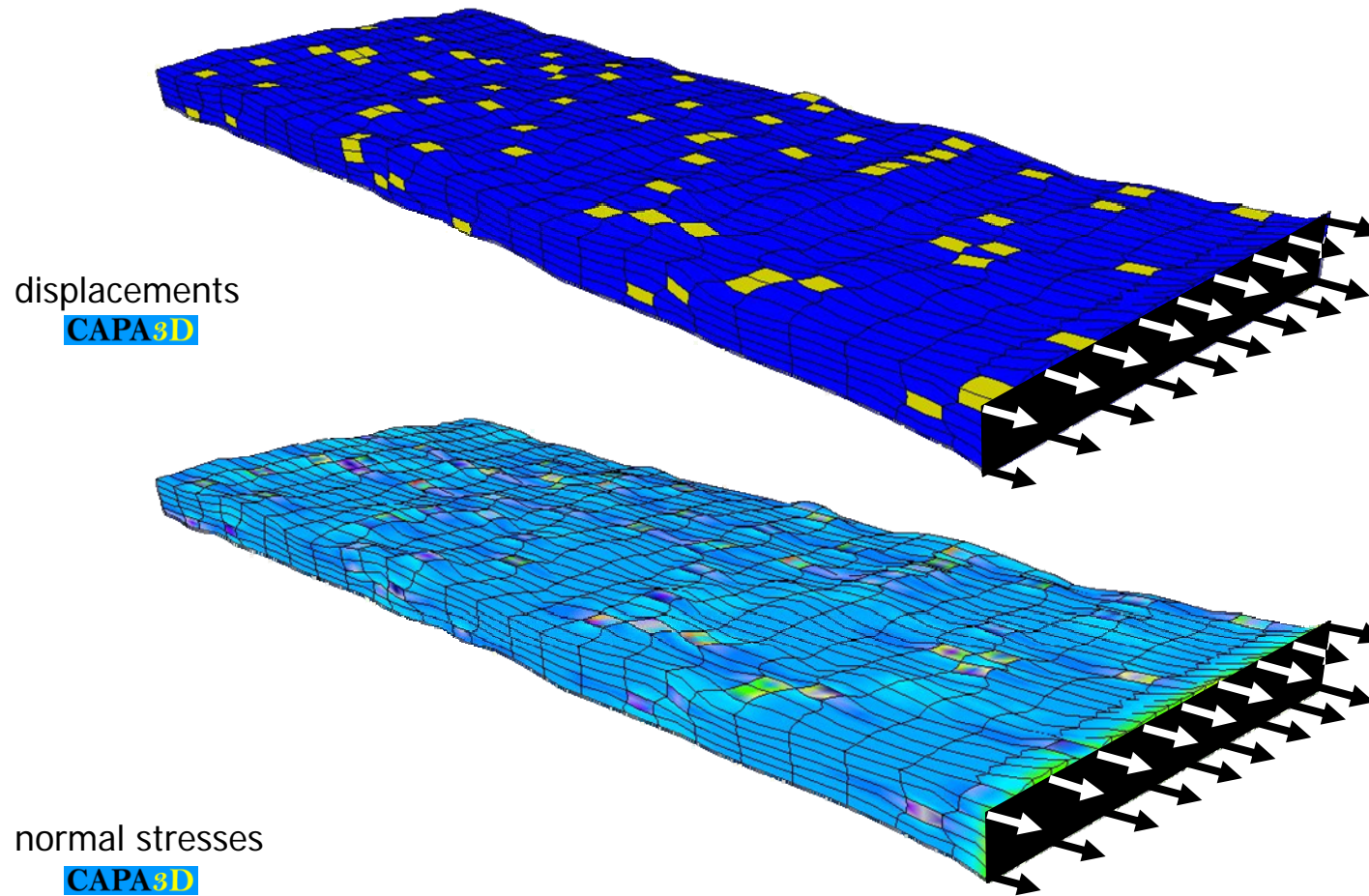

Micro-scale mechanical testing of **inhomogeneous** specimen

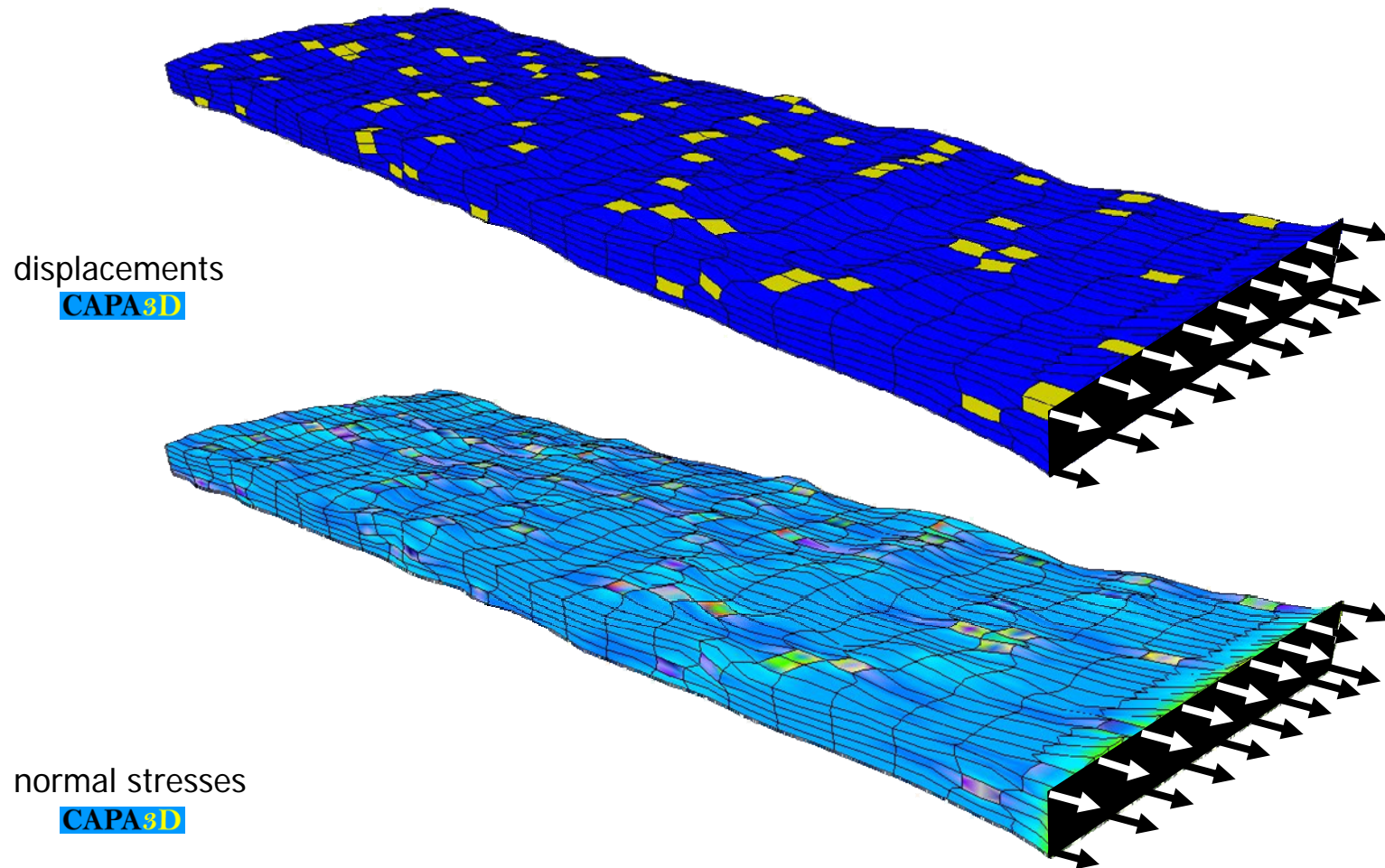

Micro-scale mechanical testing of **inhomogeneous** specimen

displacements

CAPA3D

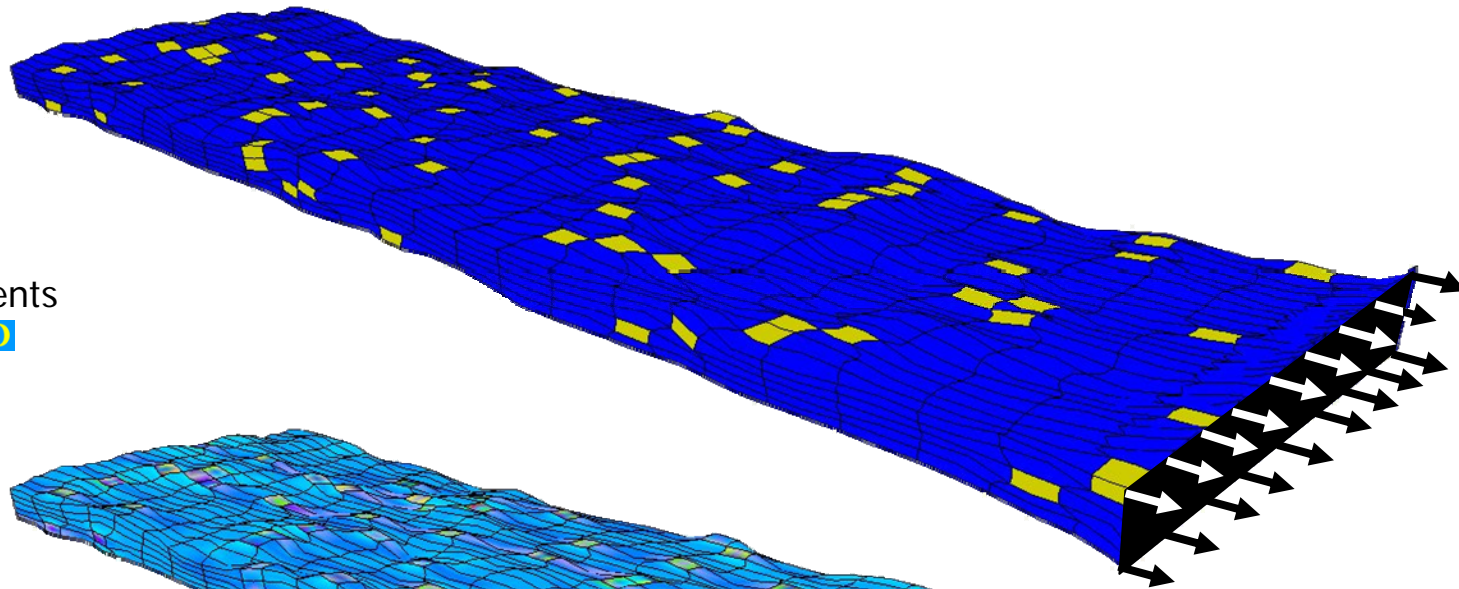

normal stresses

CAPA3D

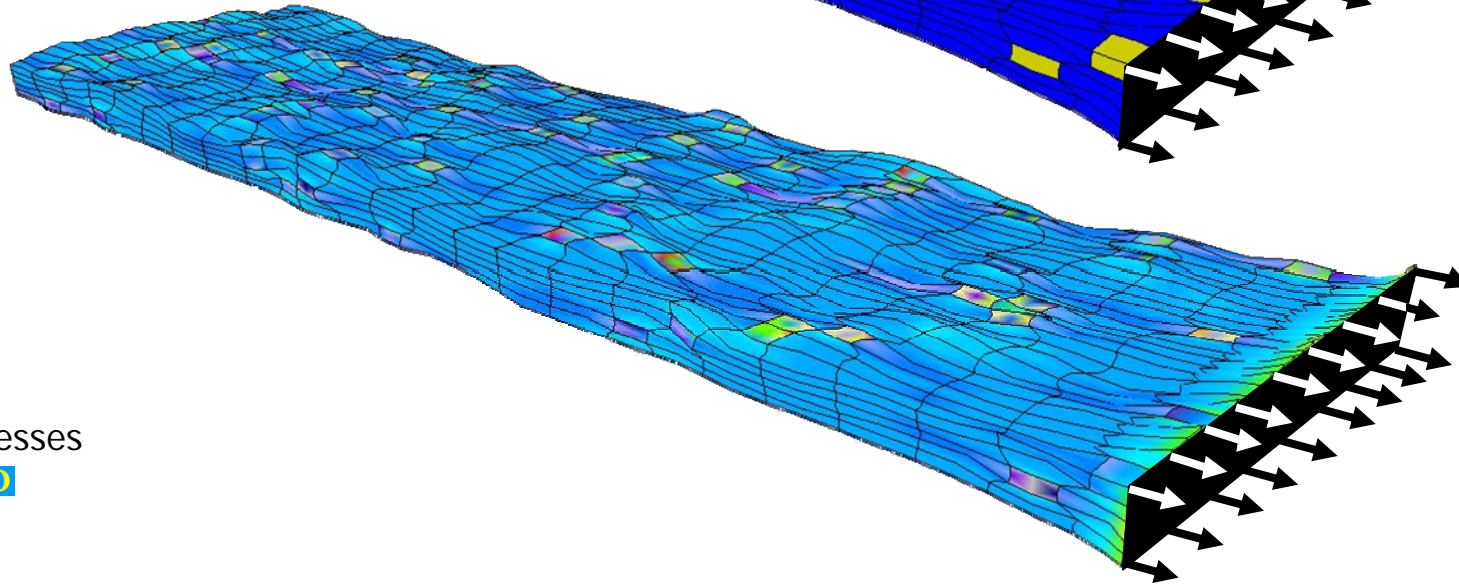

- Phase induced stiffness discontinuities

displacements

CAPA3D

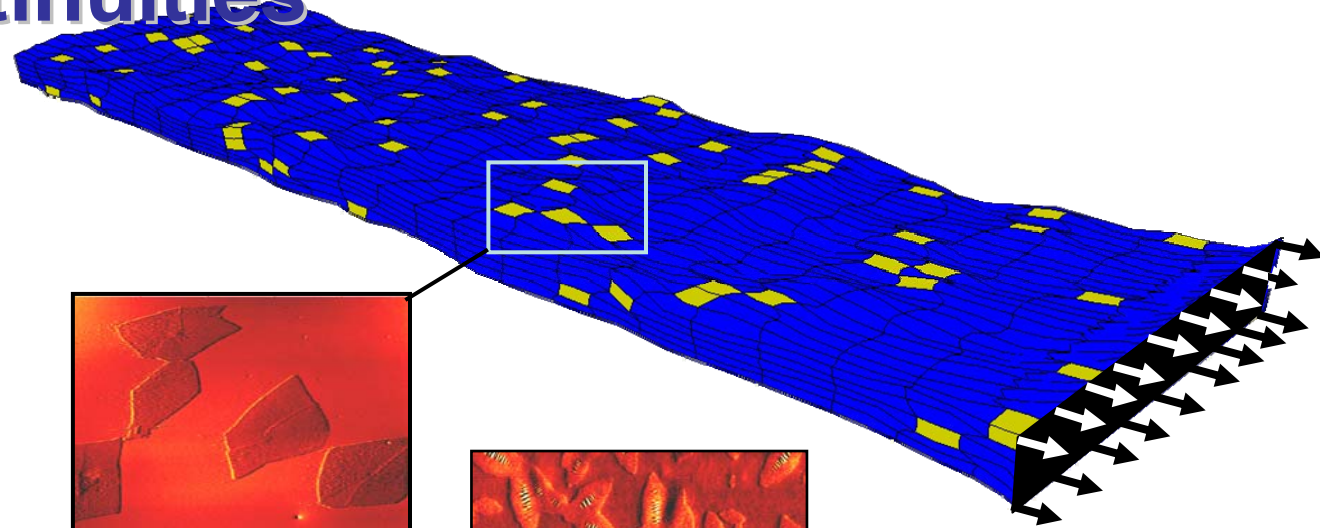

normal stresses

CAPA3D

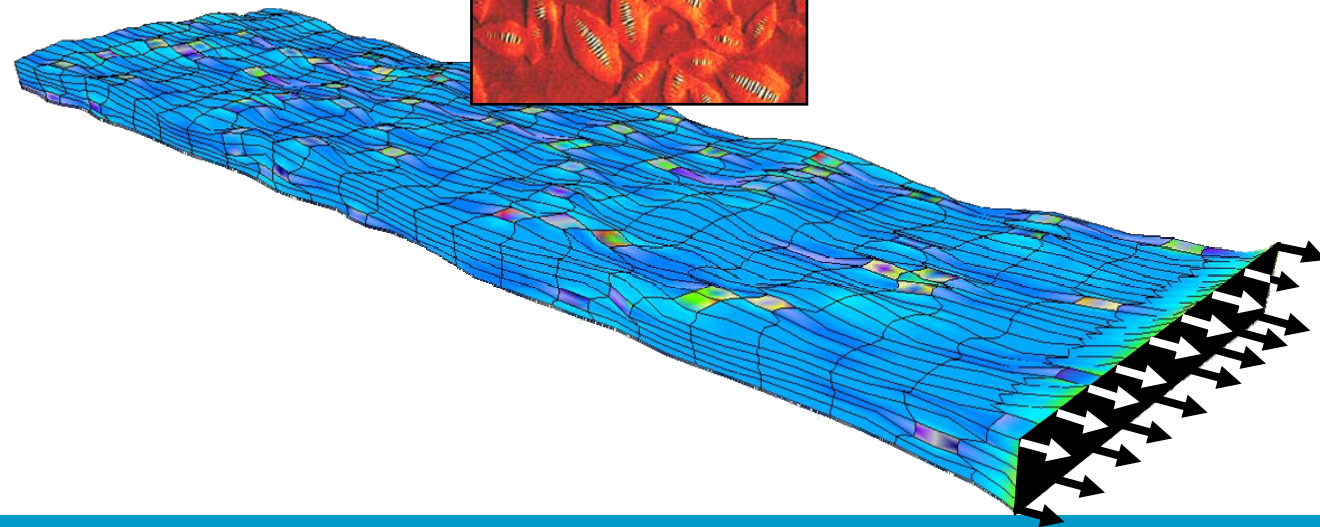

- **Mixing theory**

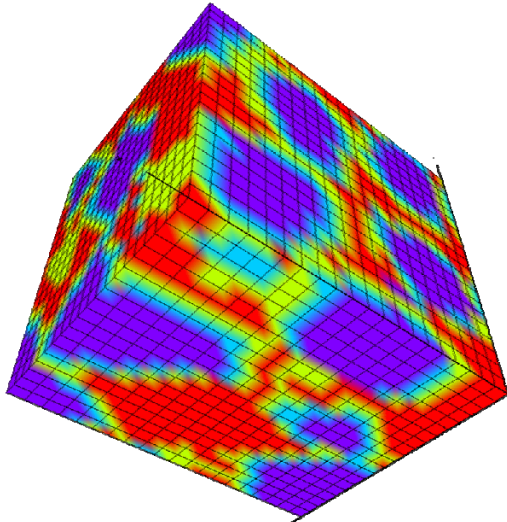

phase separated bitumen

- **Mixing theory**

interfaces → *natural stiffness discontinuities*

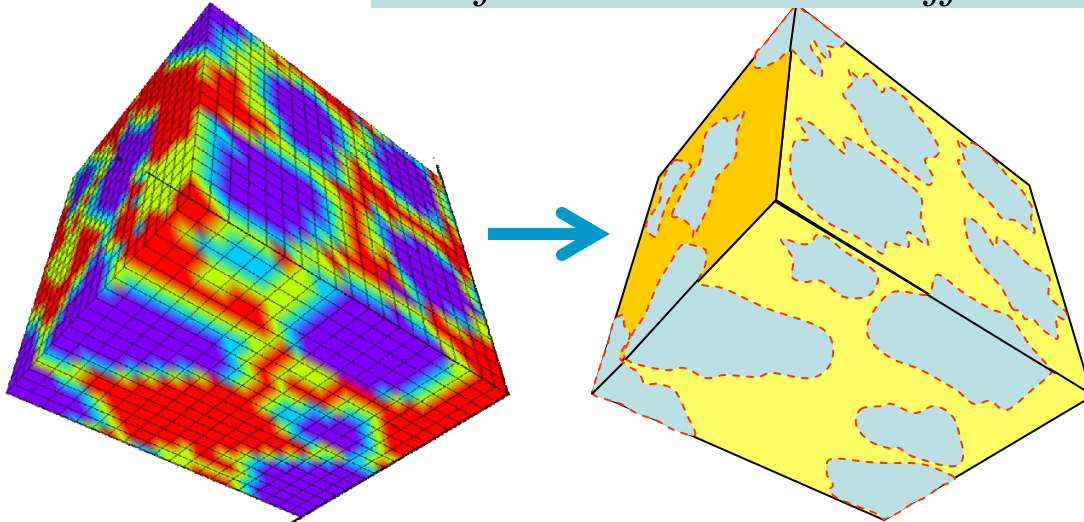

phase separated bitumen

- **Mixing theory**

interfaces → *natural stiffness discontinuities*

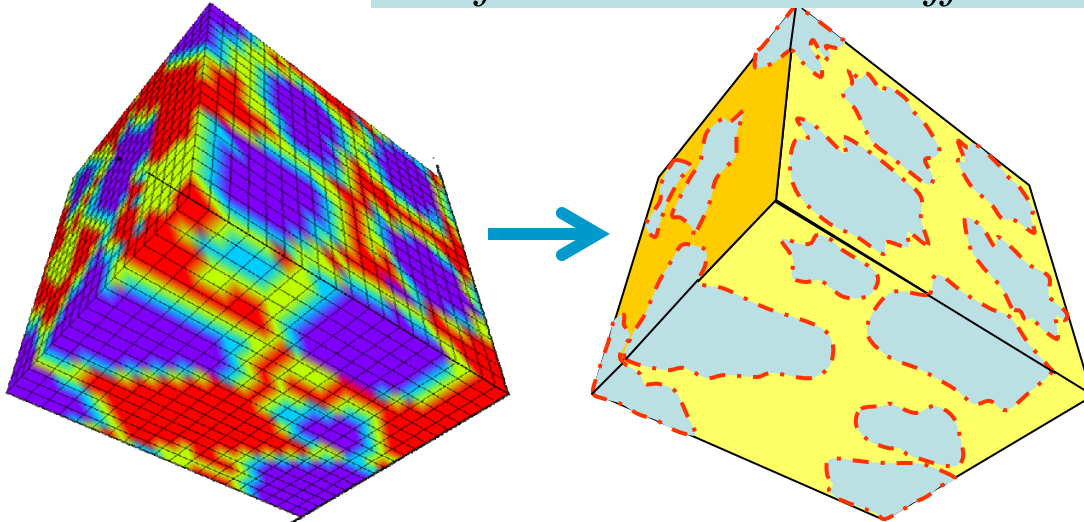

phase separated bitumen

- **Mixing theory**

interfaces → *natural stiffness discontinuities*

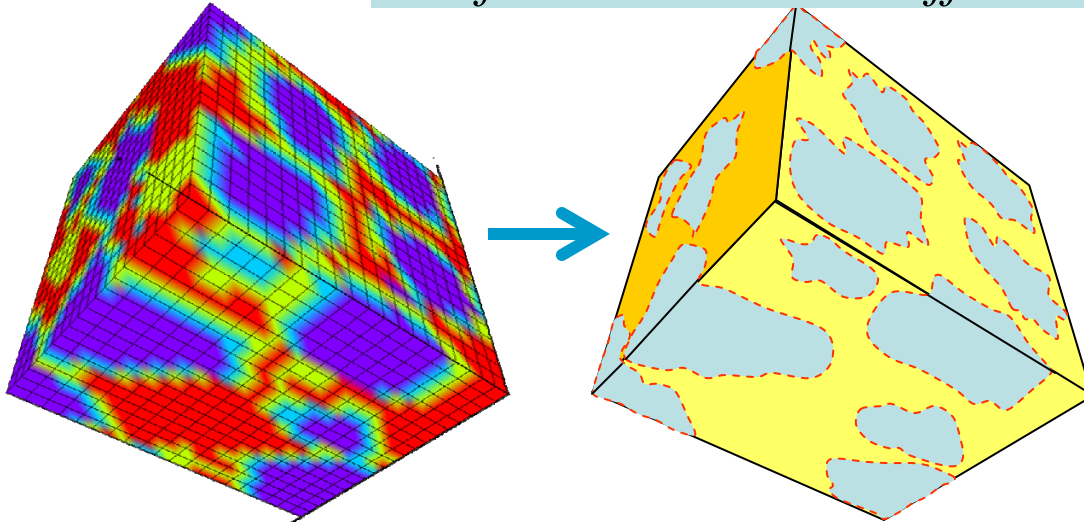

phase separated bitumen

- **Mixing theory**

interfaces → *natural stiffness discontinuities*

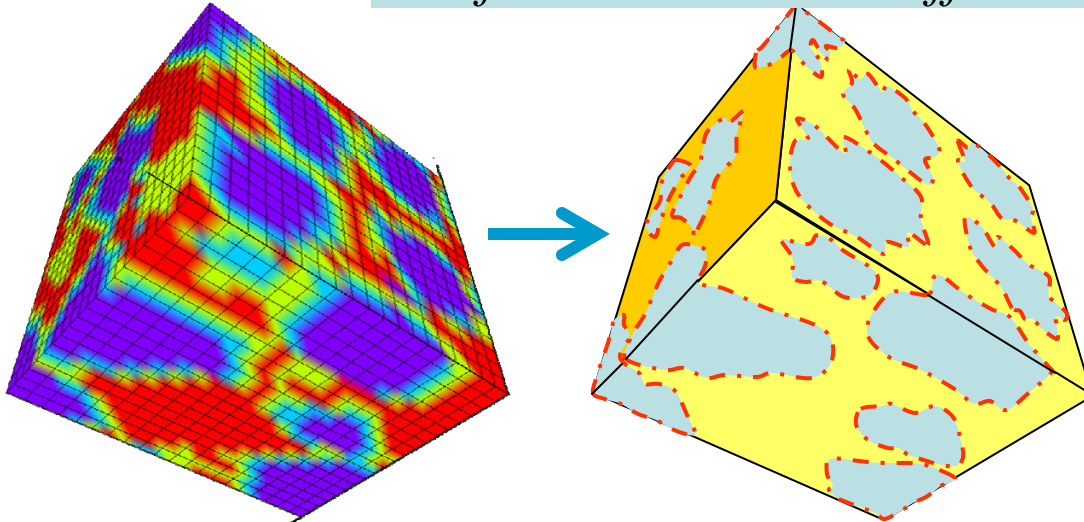

phase separated bitumen

- **Mixing theory**

interfaces → *natural stiffness discontinuities*

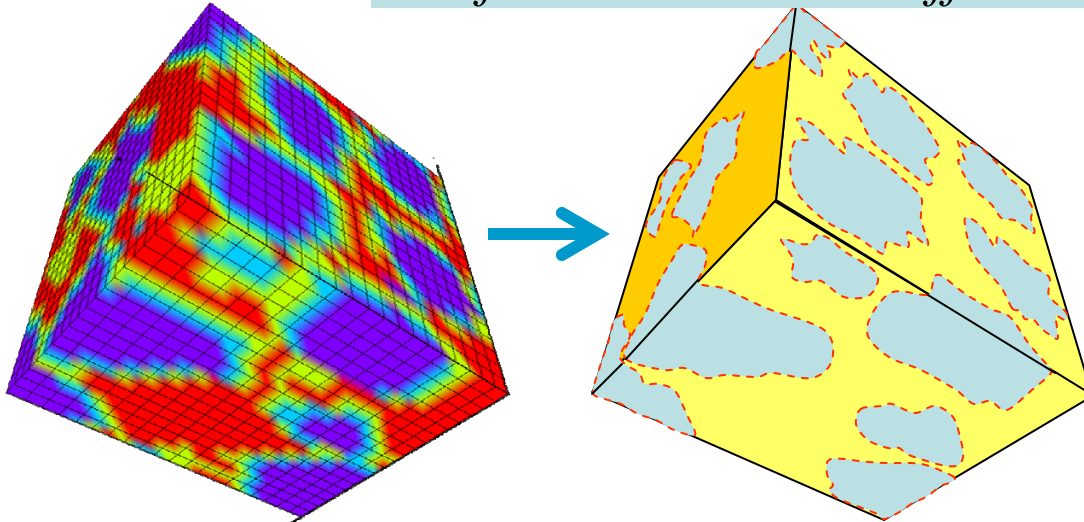

phase separated bitumen

- **Mixing theory**

interfaces → *natural stiffness discontinuities*

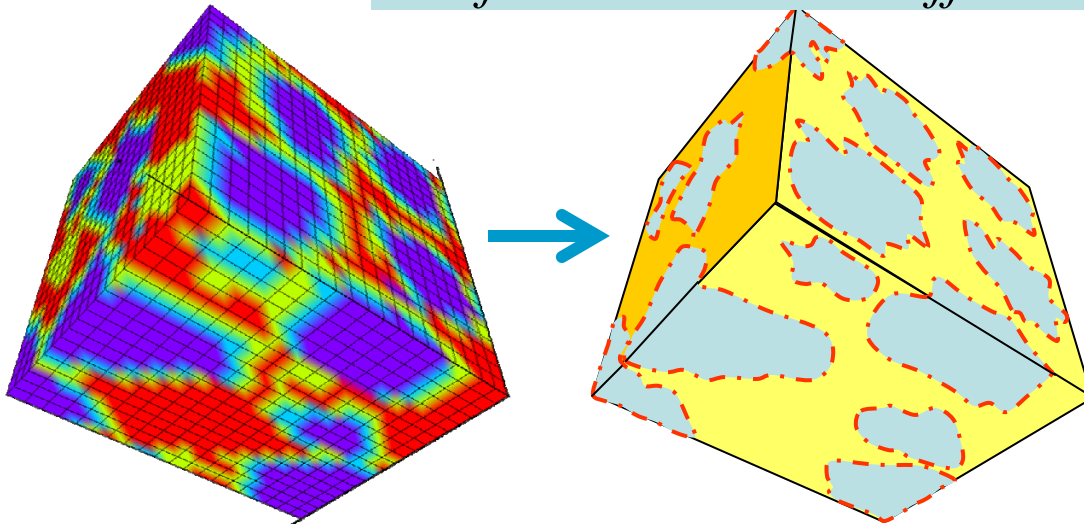

phase separated bitumen

- **Mixing theory**

interfaces → *natural stiffness discontinuities*

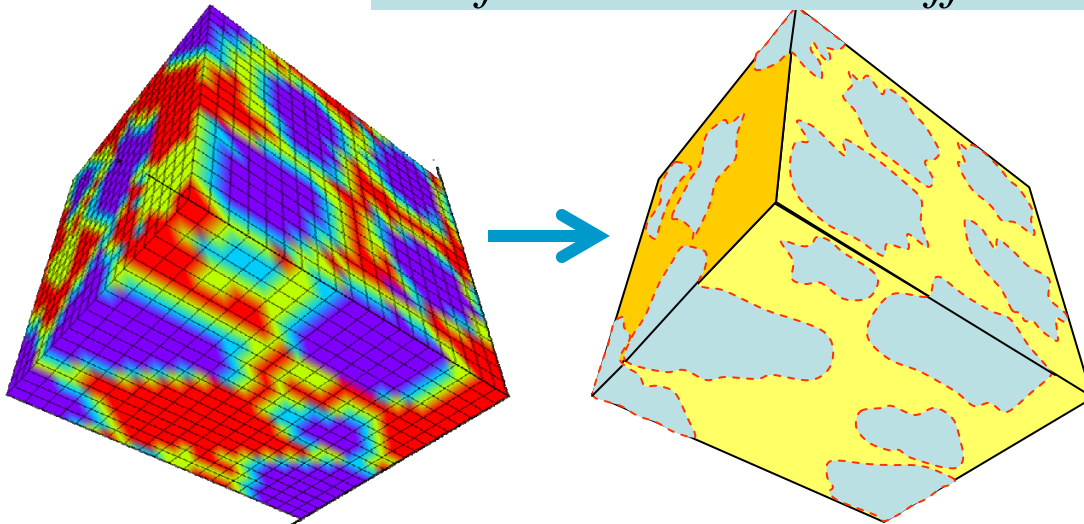

phase separated bitumen

- **Mixing theory**

interfaces → *natural stiffness discontinuities*

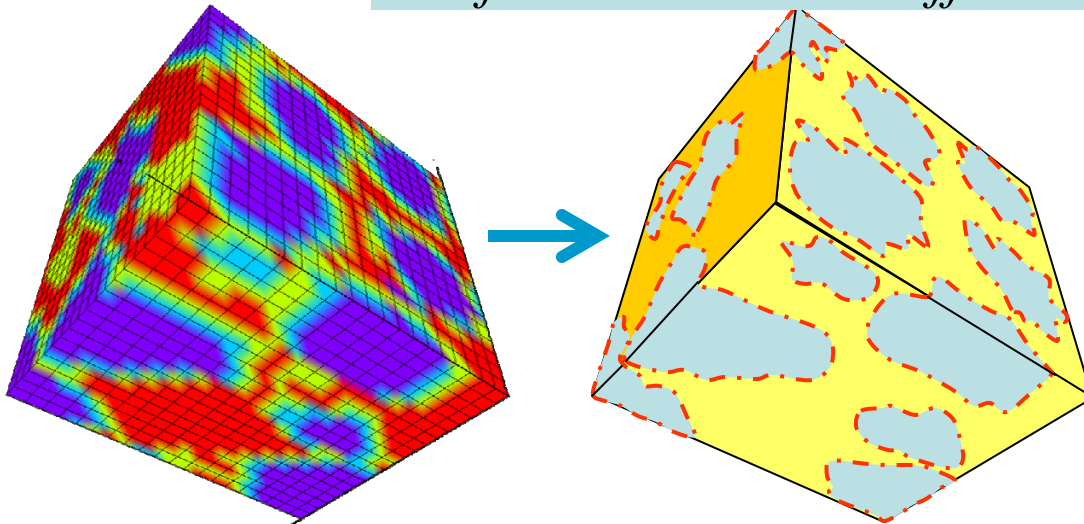

phase separated bitumen

- **Mixing theory**

interfaces → *natural stiffness discontinuities*

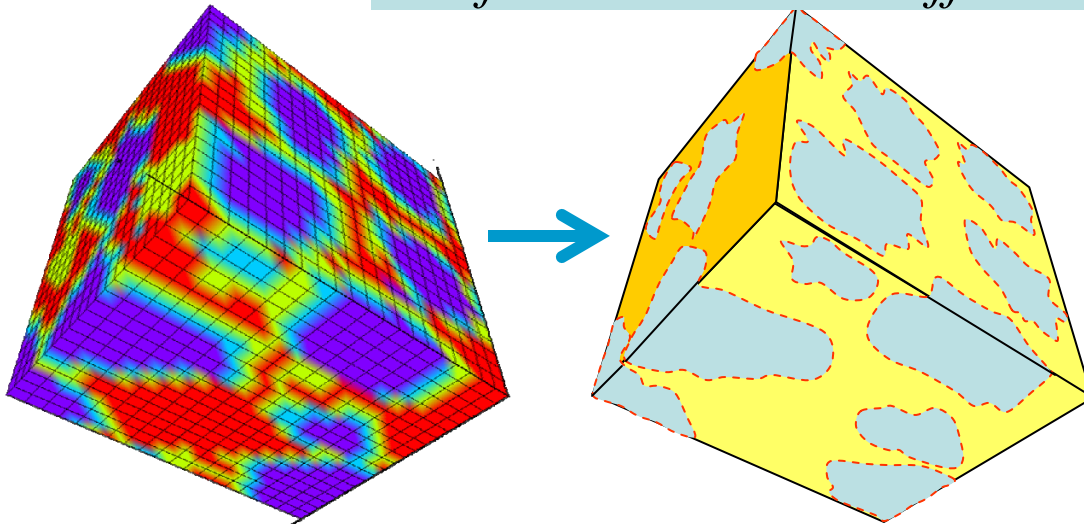

phase separated bitumen

- **Mixing theory**

interfaces → *natural stiffness discontinuities*

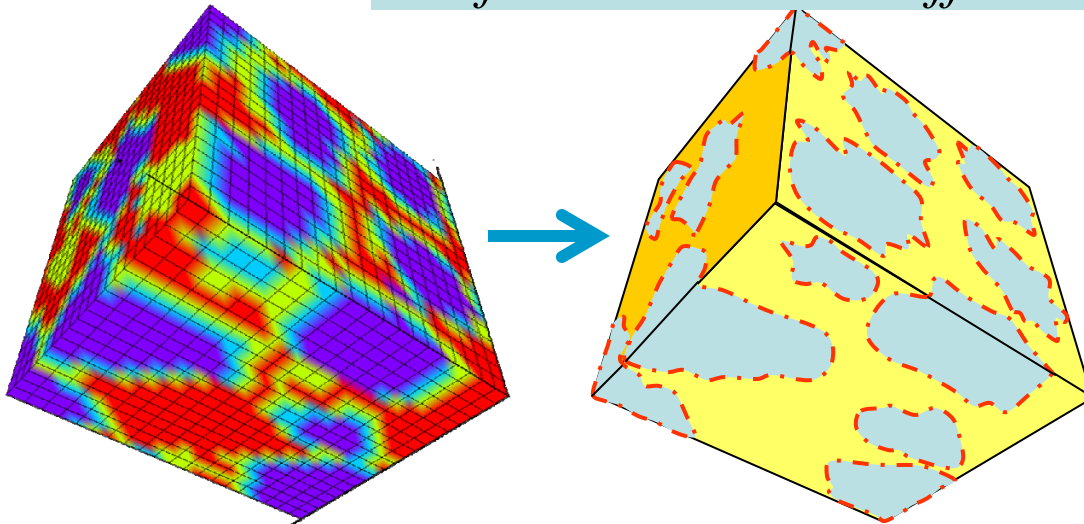

phase separated bitumen

- **Mixing theory**

interfaces → *natural stiffness discontinuities*

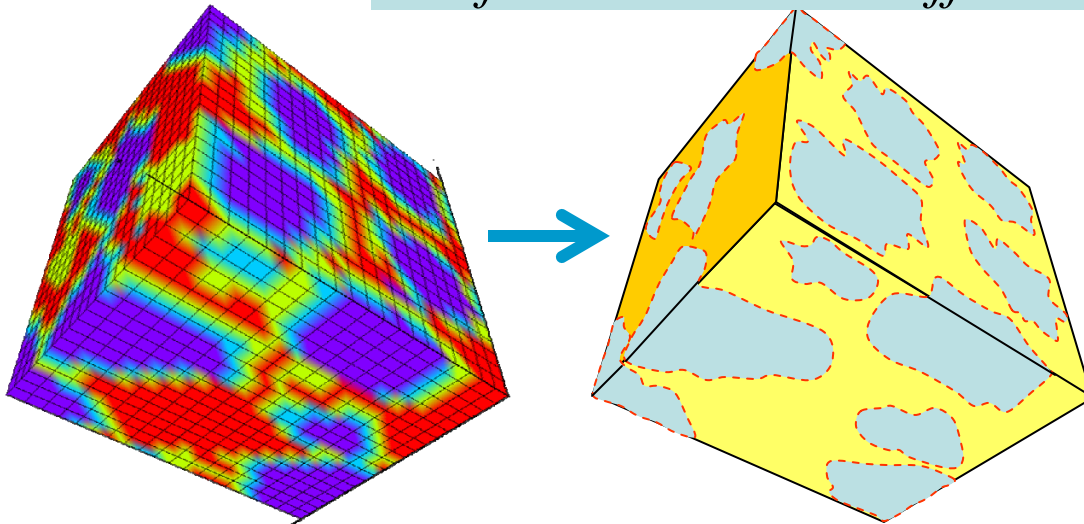

phase separated bitumen

- **Mixing theory**

interfaces → *natural stiffness discontinuities*

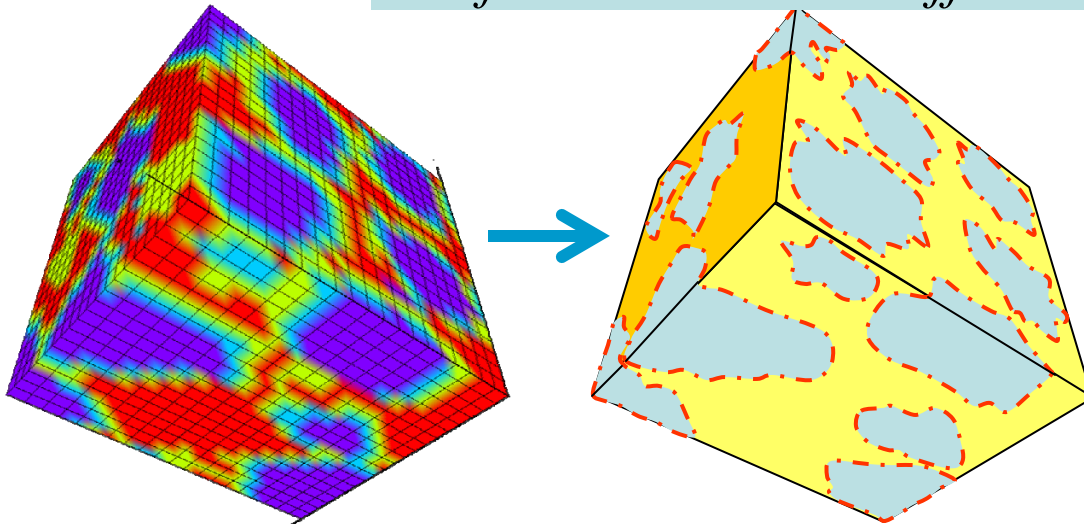

phase separated bitumen

• Crazeing development

interfaces → *natural stress inducers*

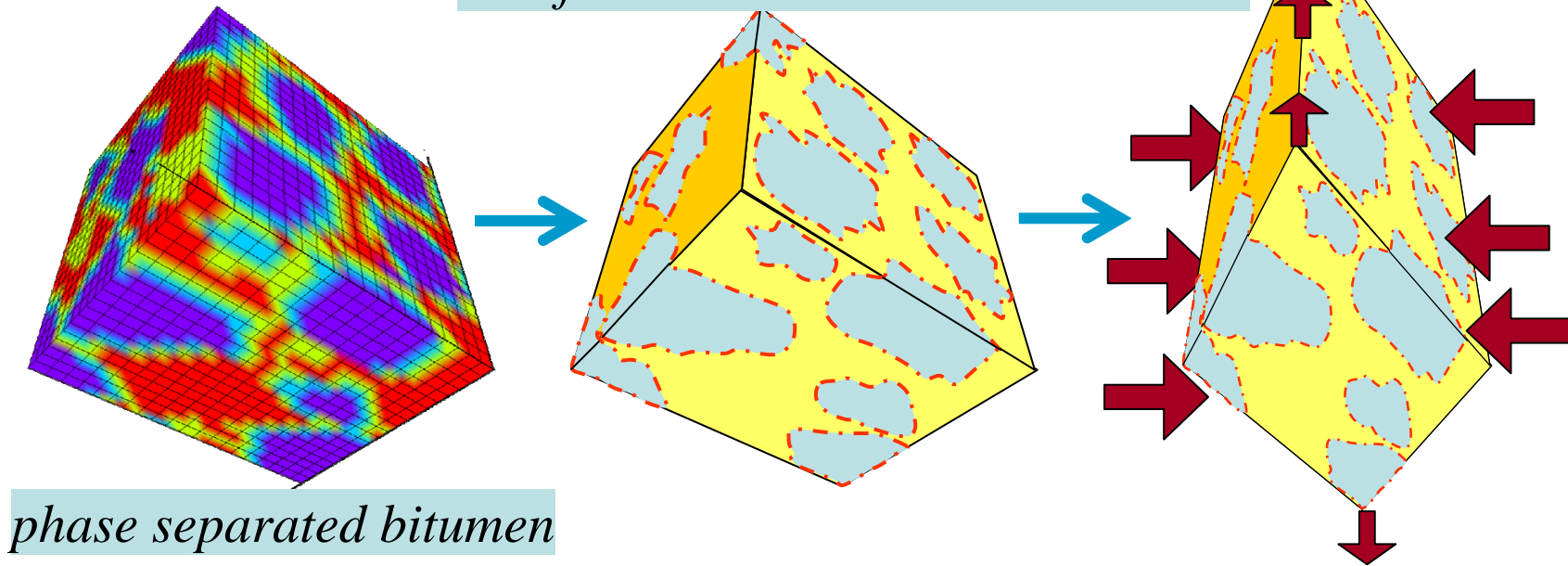

• Crazeing development

interfaces → *natural stress inducers*

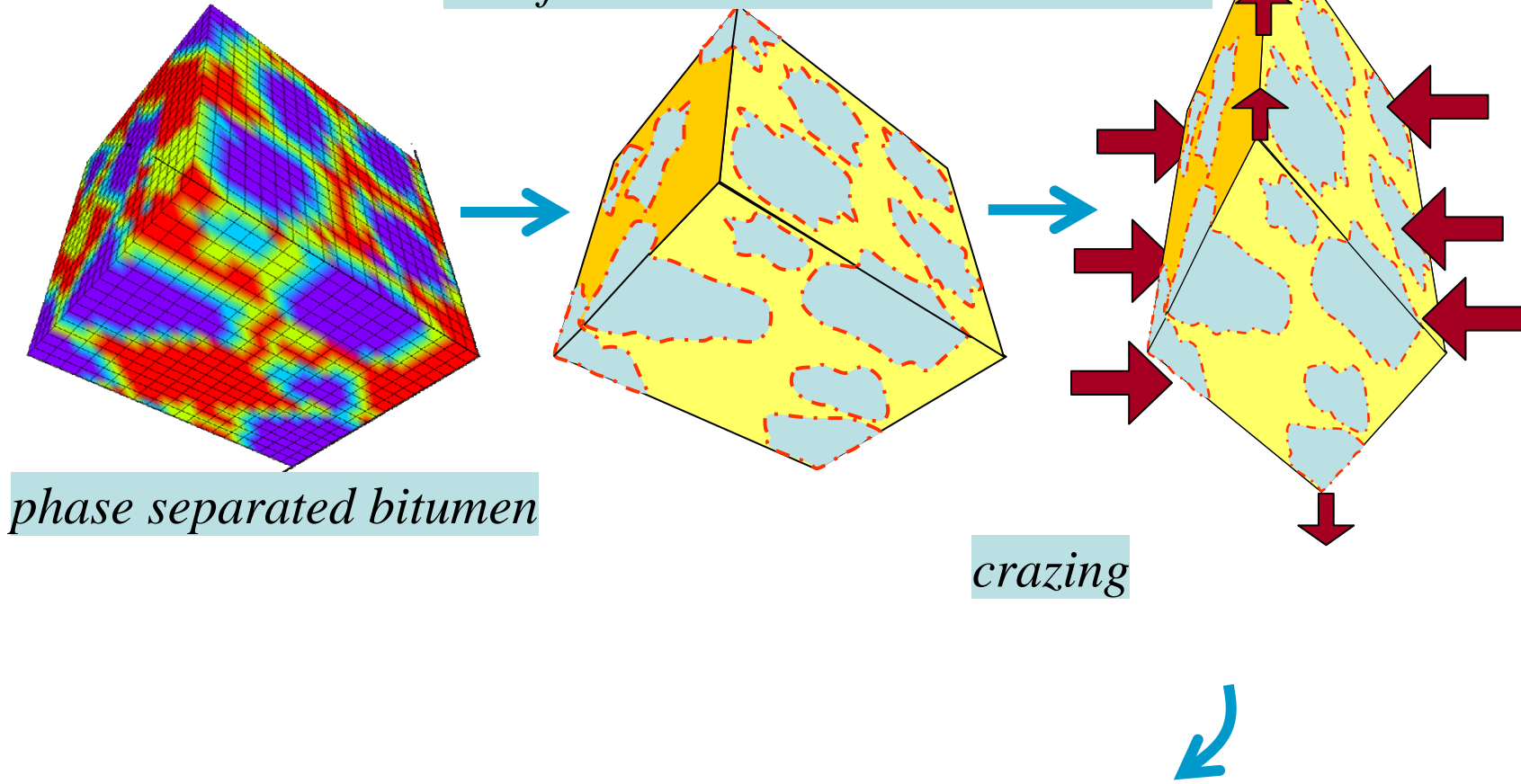

• Crazeing development

interfaces → *natural stress inducers*

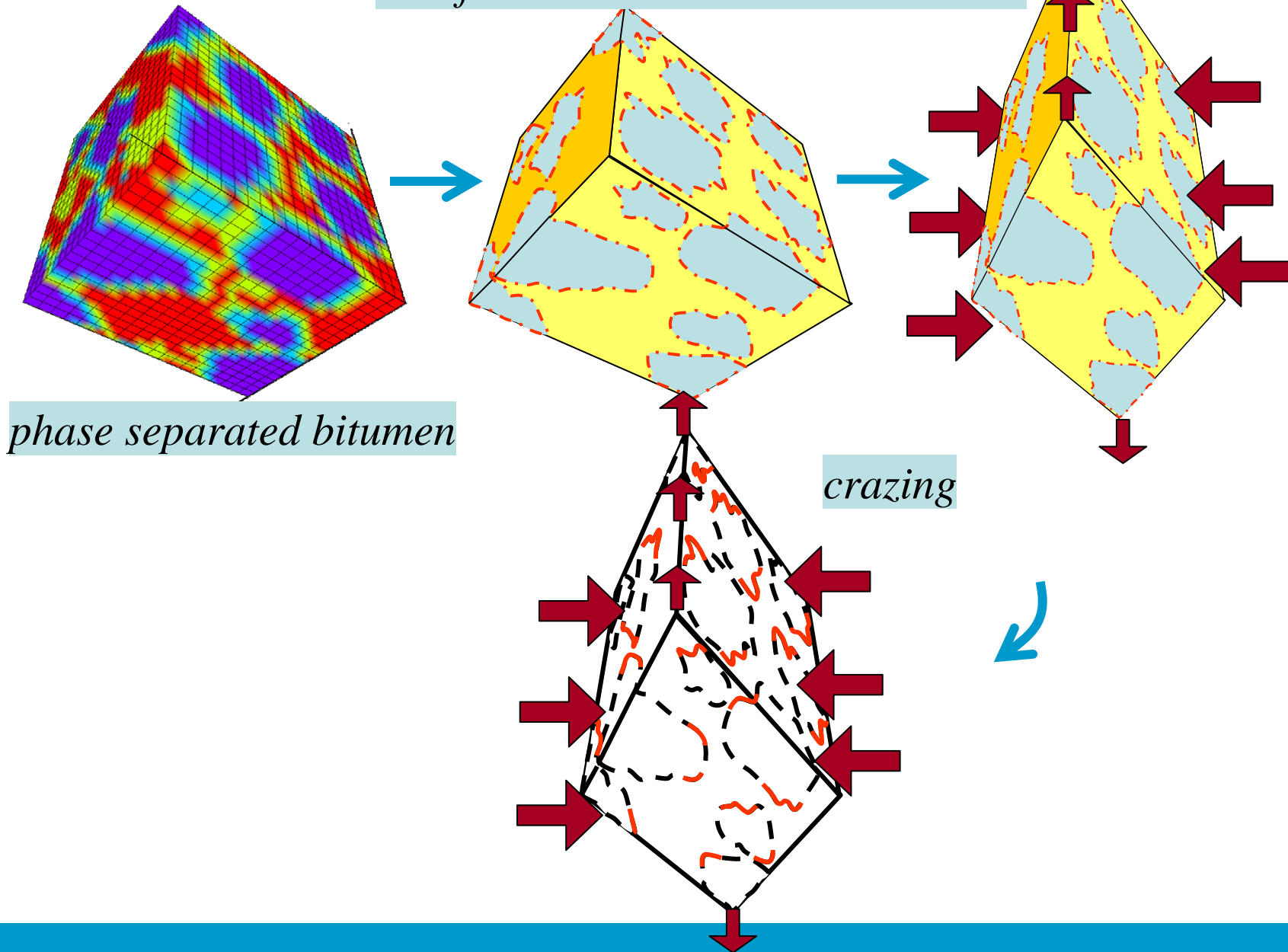

• Crazing development

interfaces → *natural stress inducers*

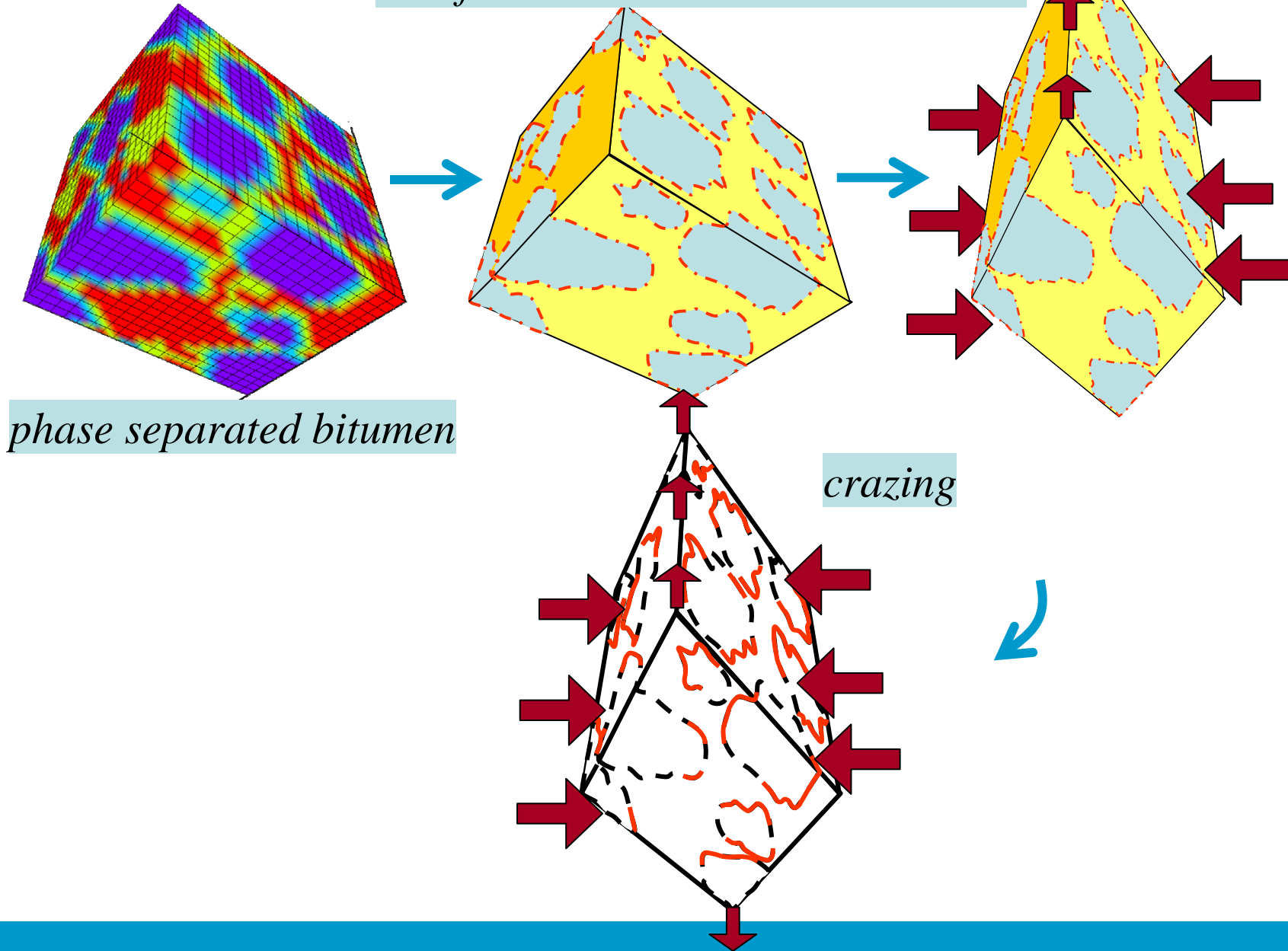

• Craze development

interfaces → *natural stress inducers*

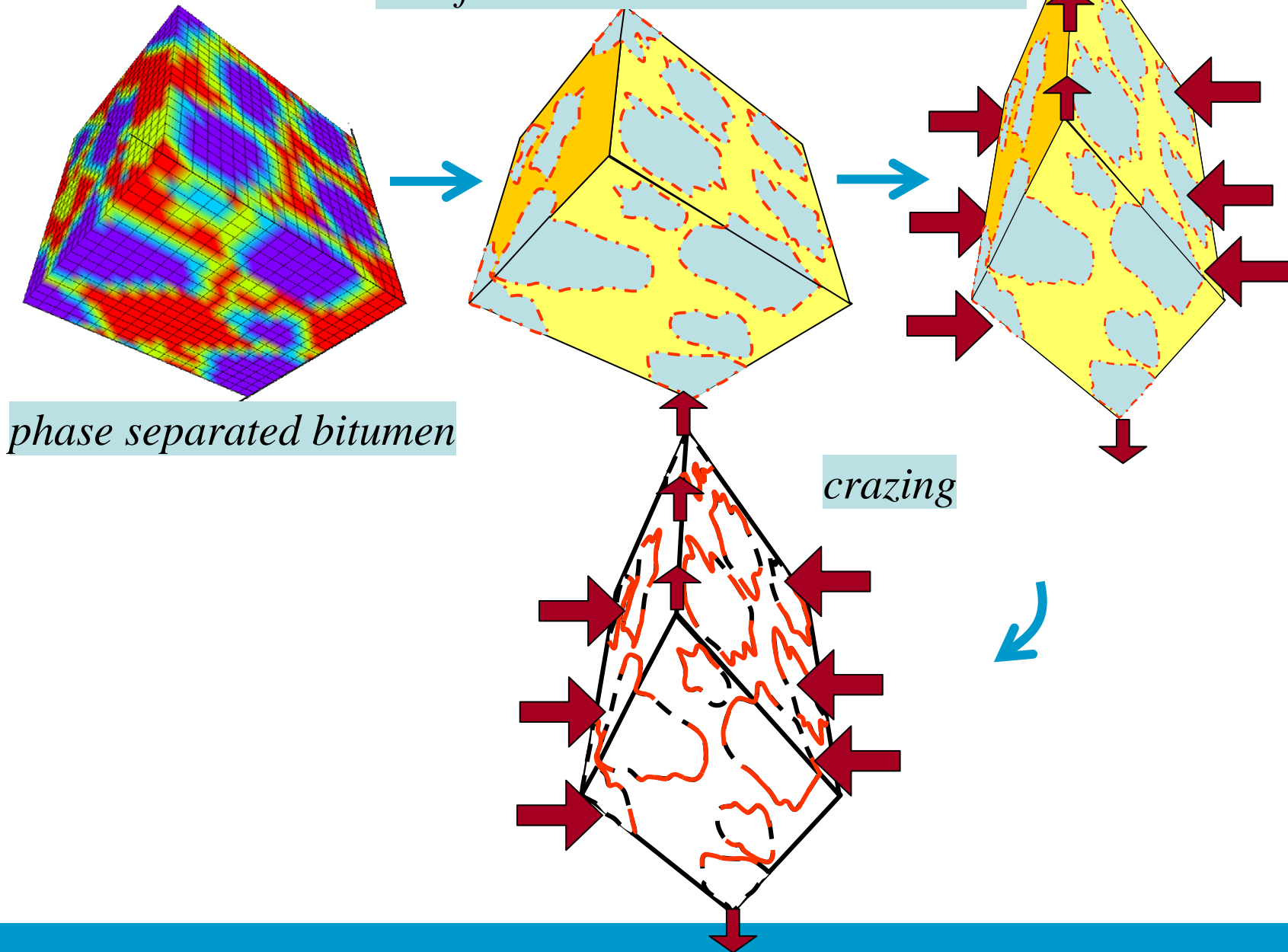

• Crazeing development

interfaces → *natural stress inducers*

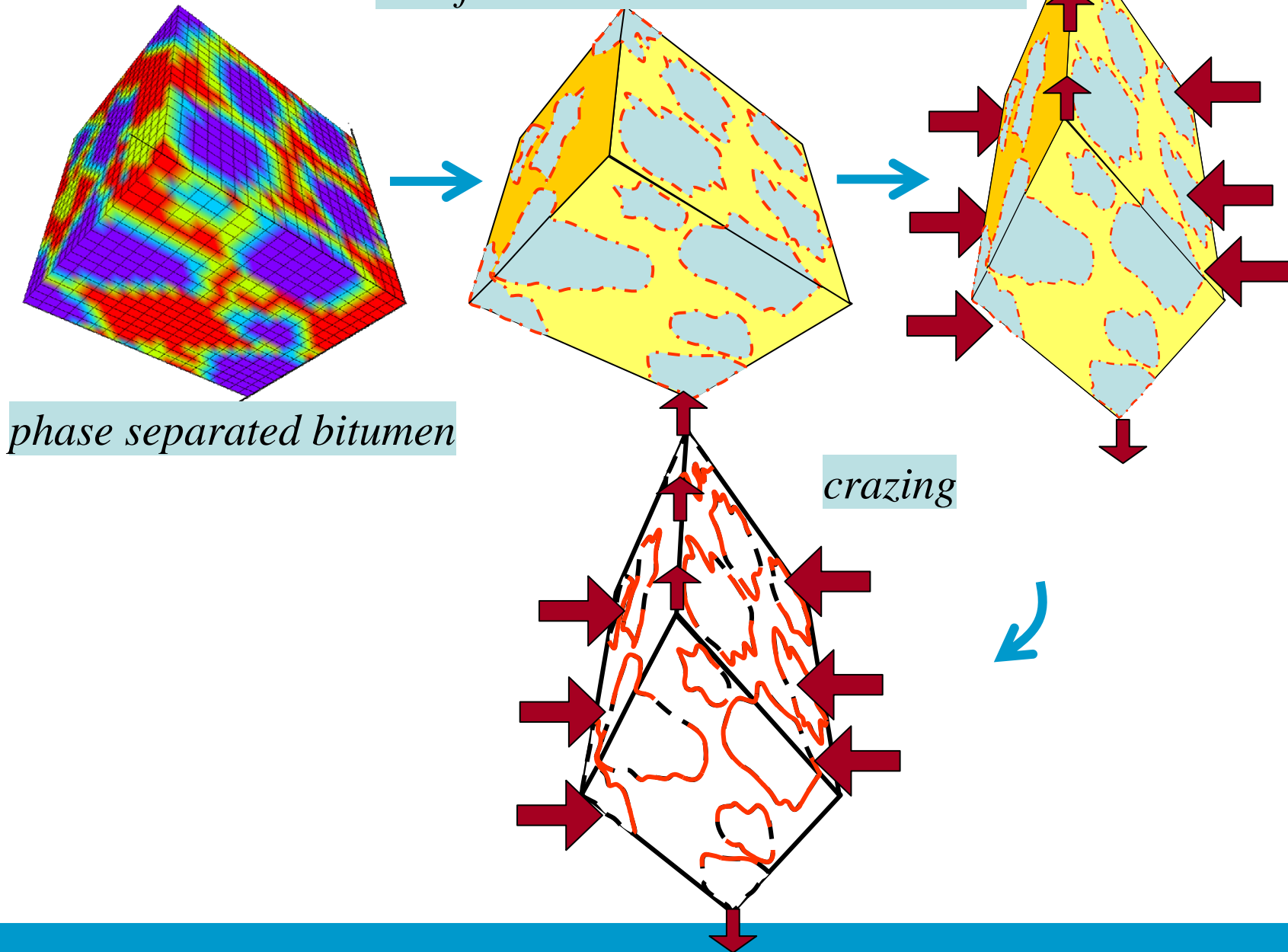

• Craze development

interfaces → *natural stress inducers*

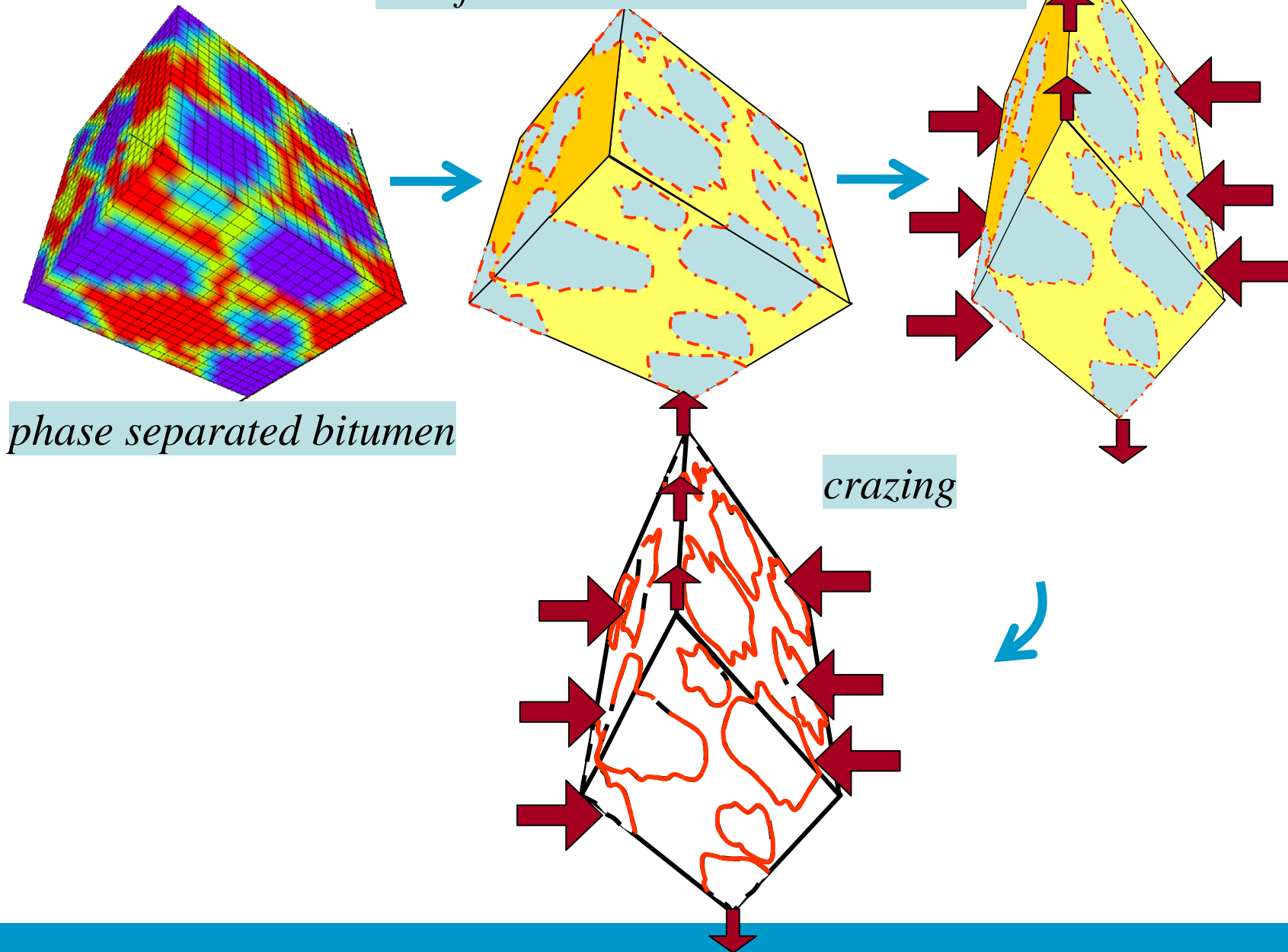

• Craze development

interfaces → *natural stress inducers*

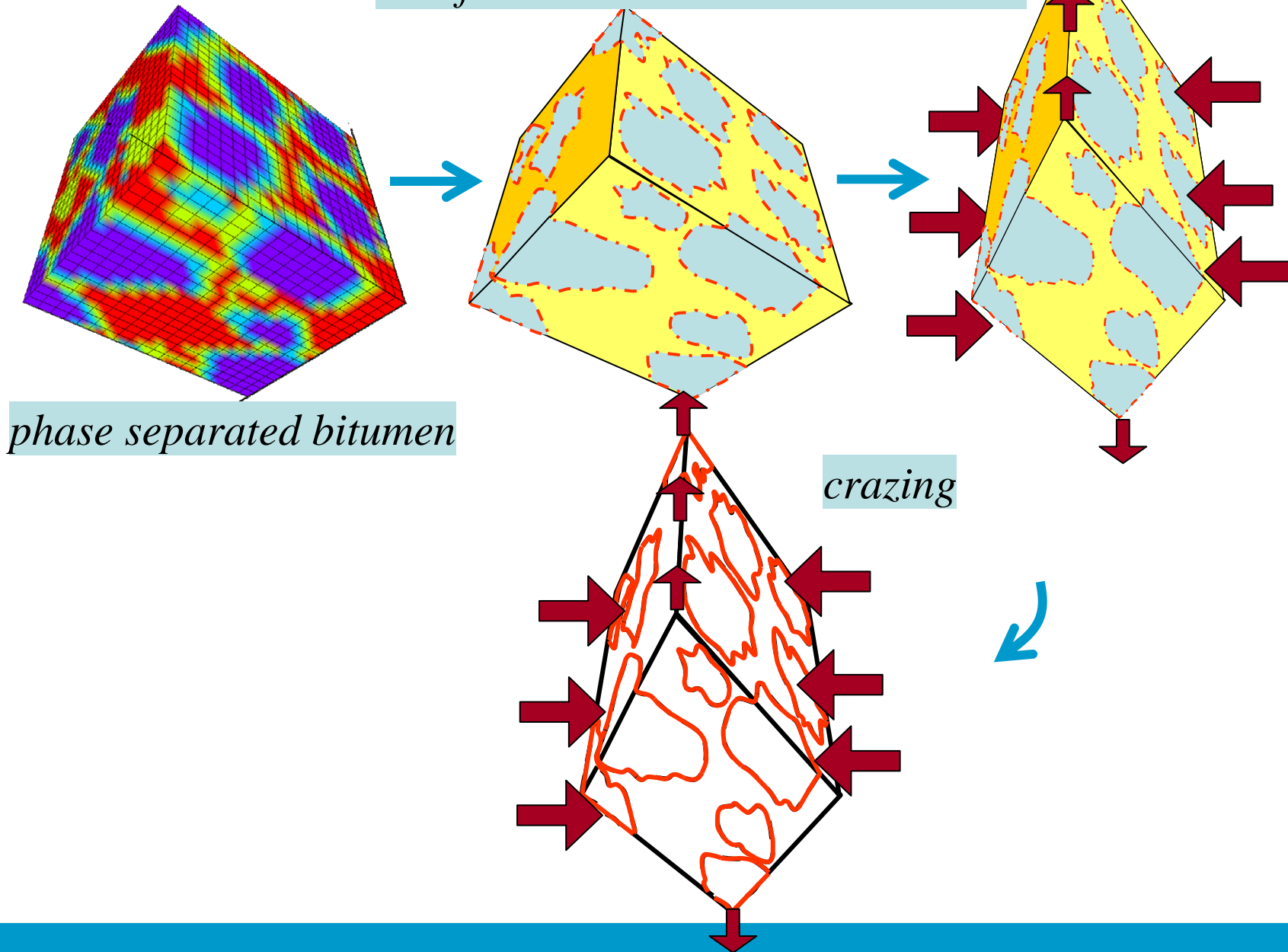

• Craze development

interfaces → *natural stress inducers*

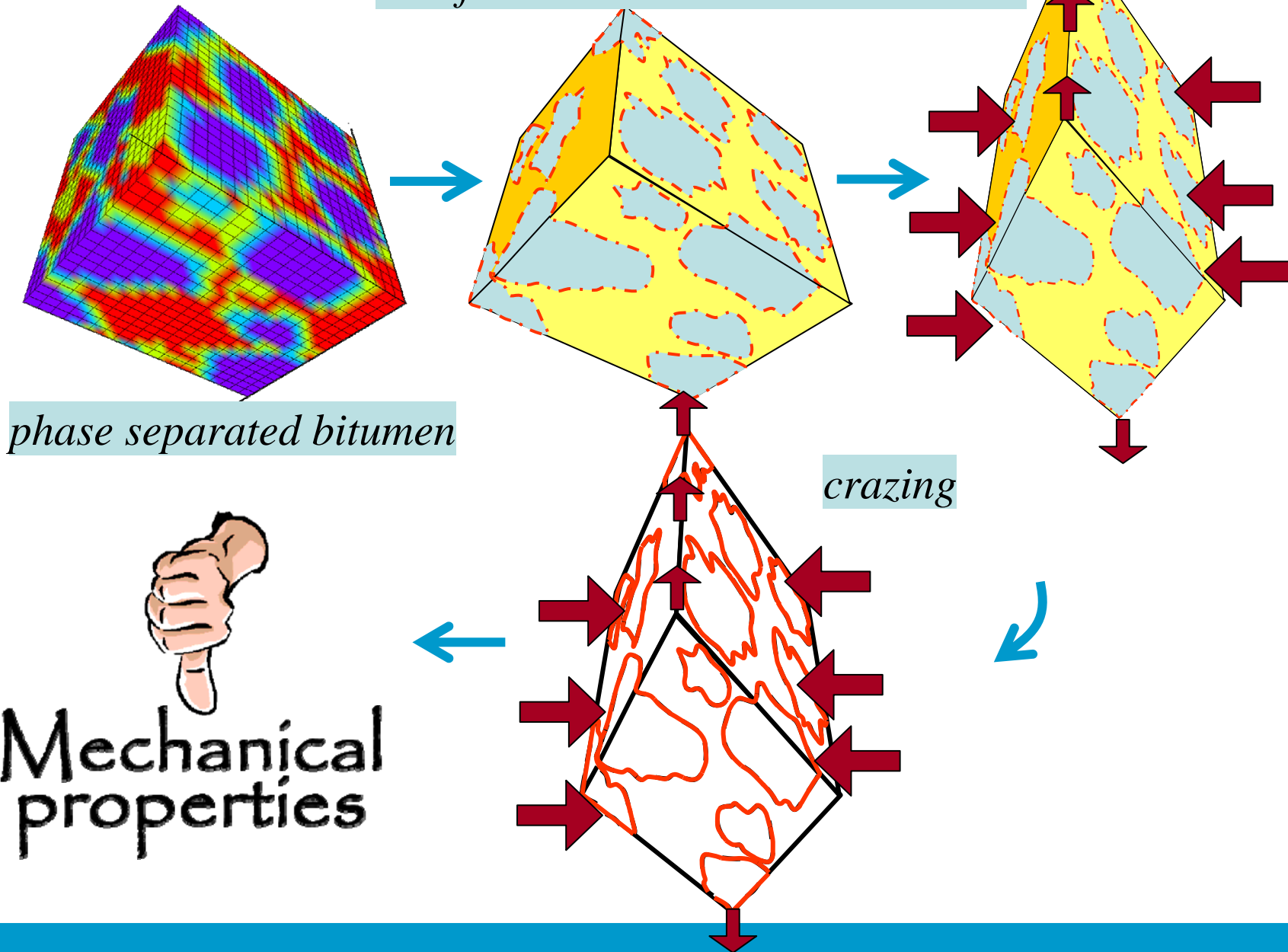

• Craze development

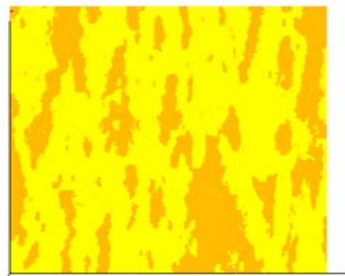
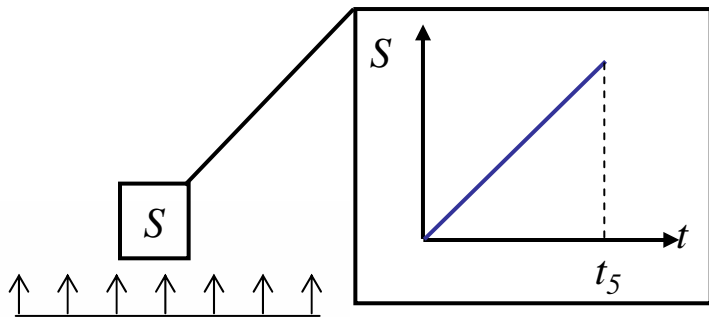

t_1

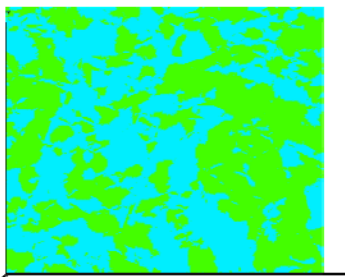

t_1

S_{11}



S_{12}



• Craze development

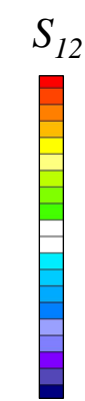
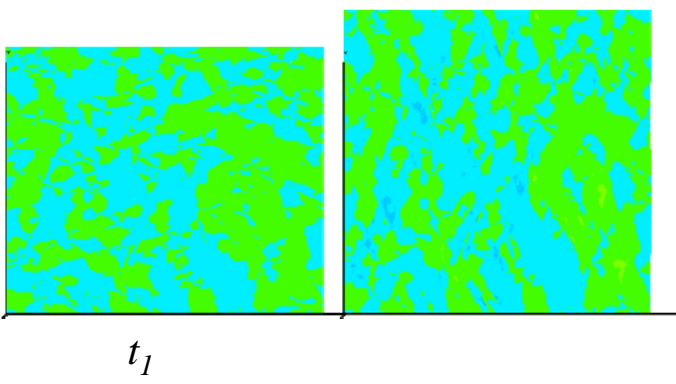
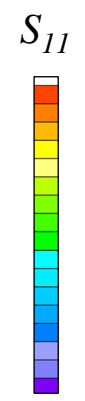
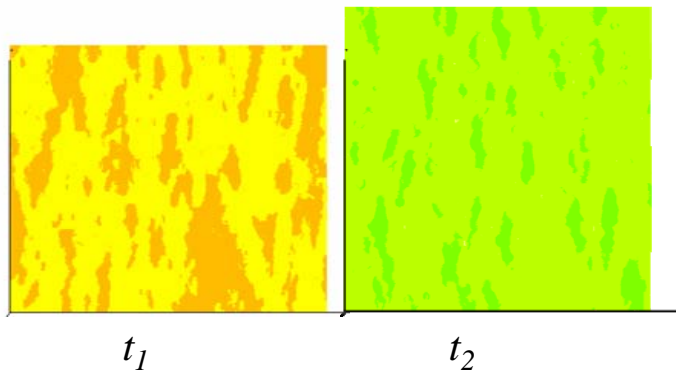
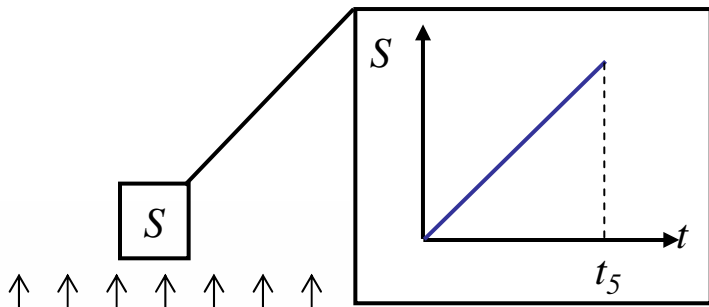

• Craze development

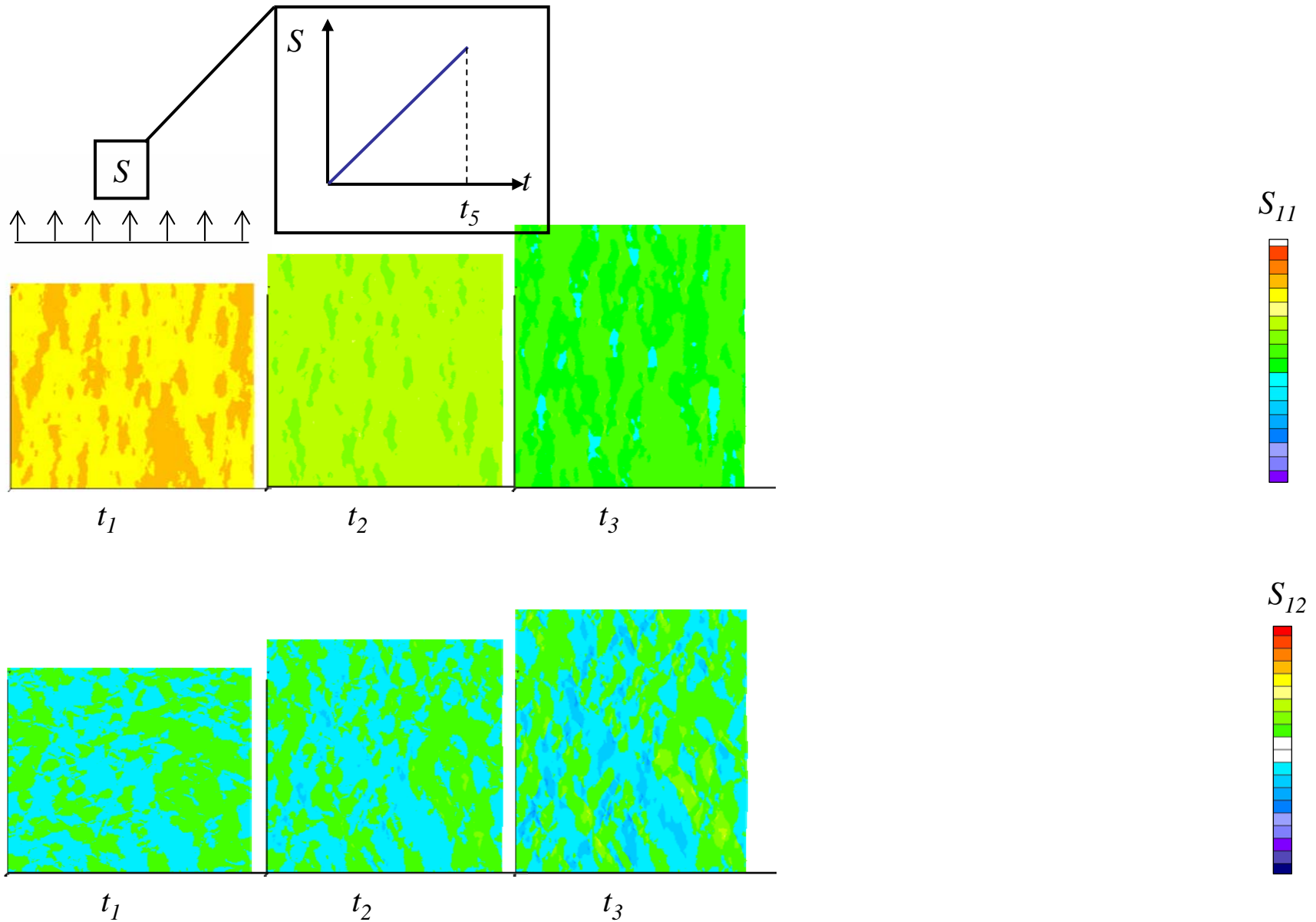

• Craze development

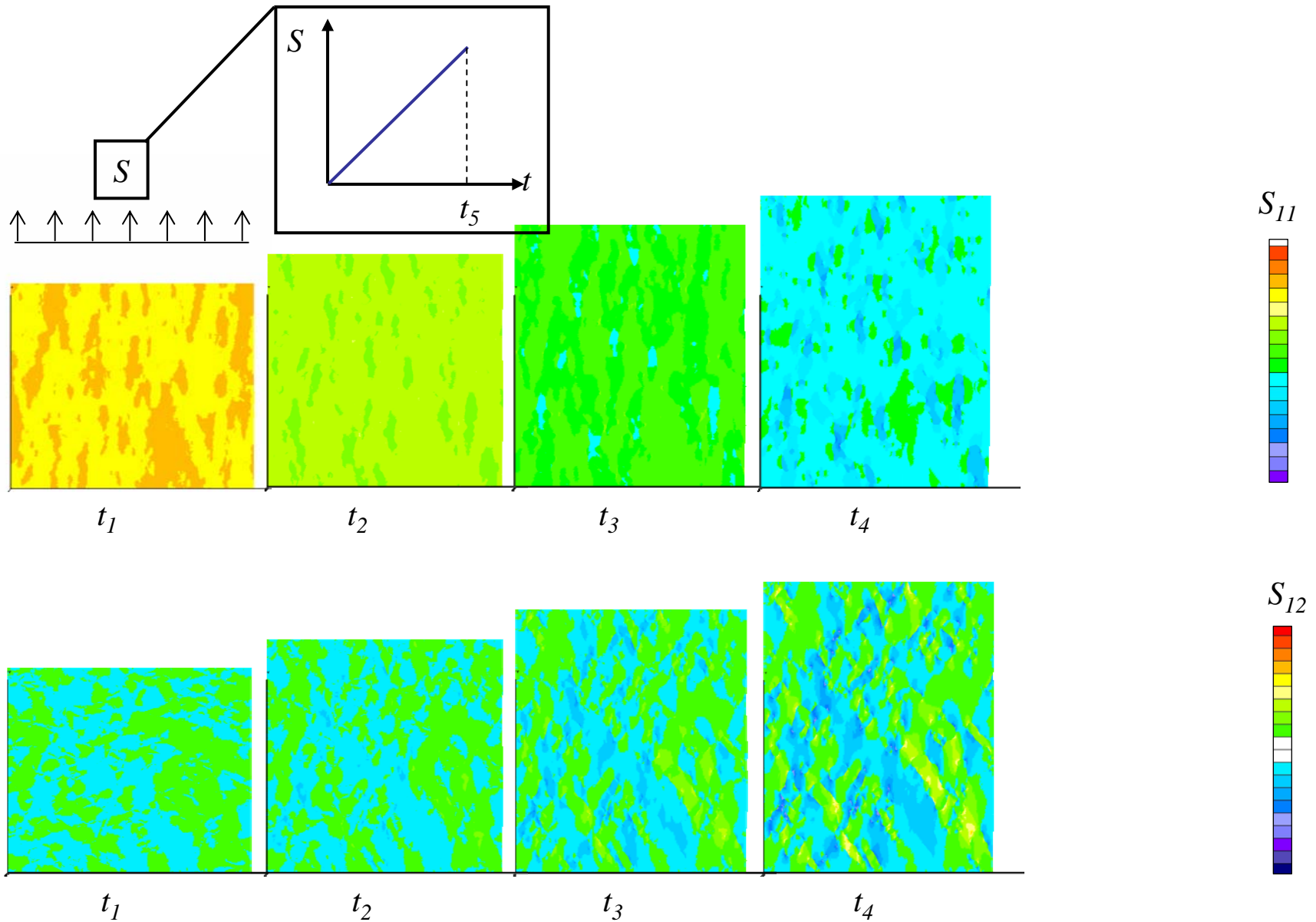

• Craze development

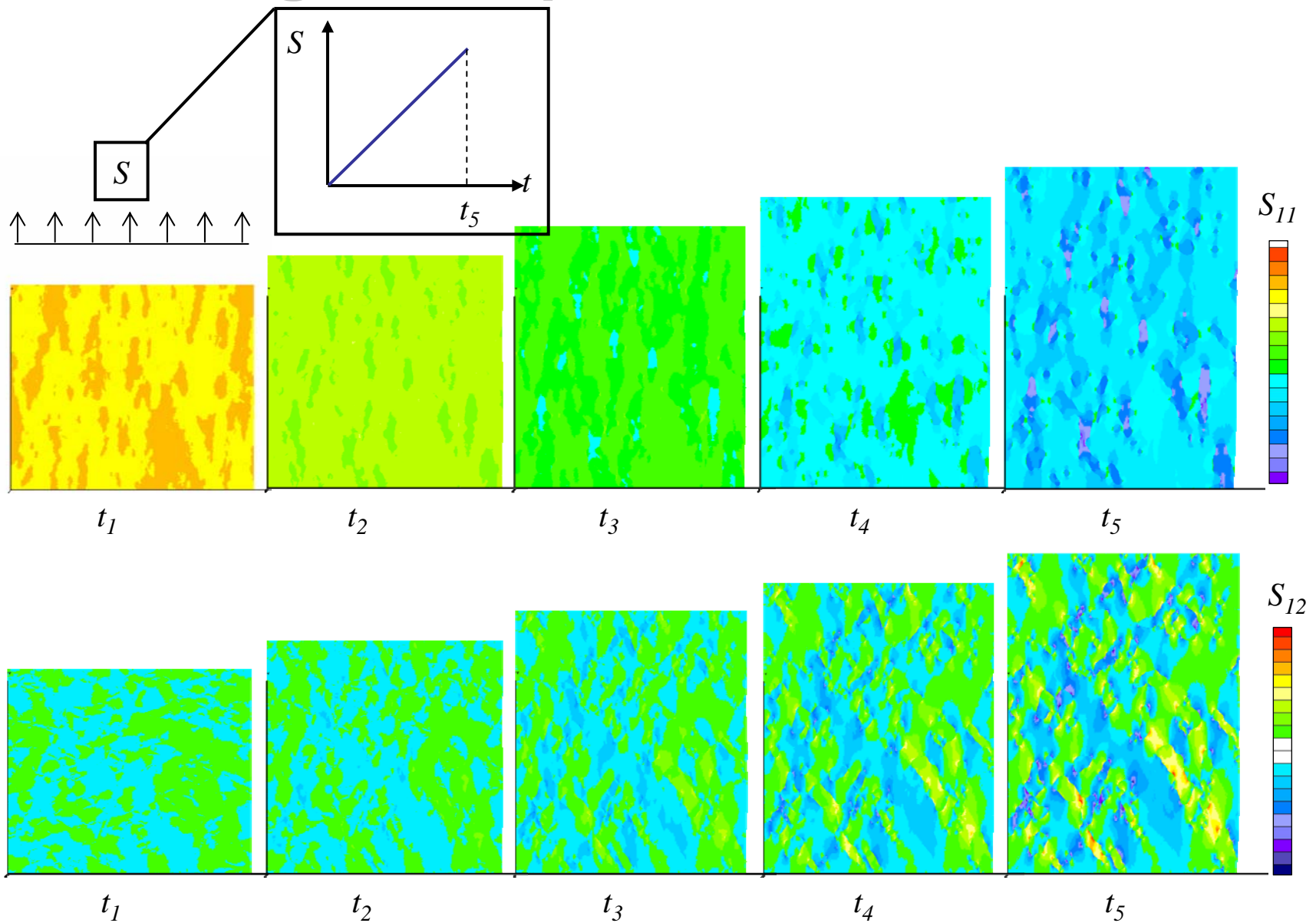

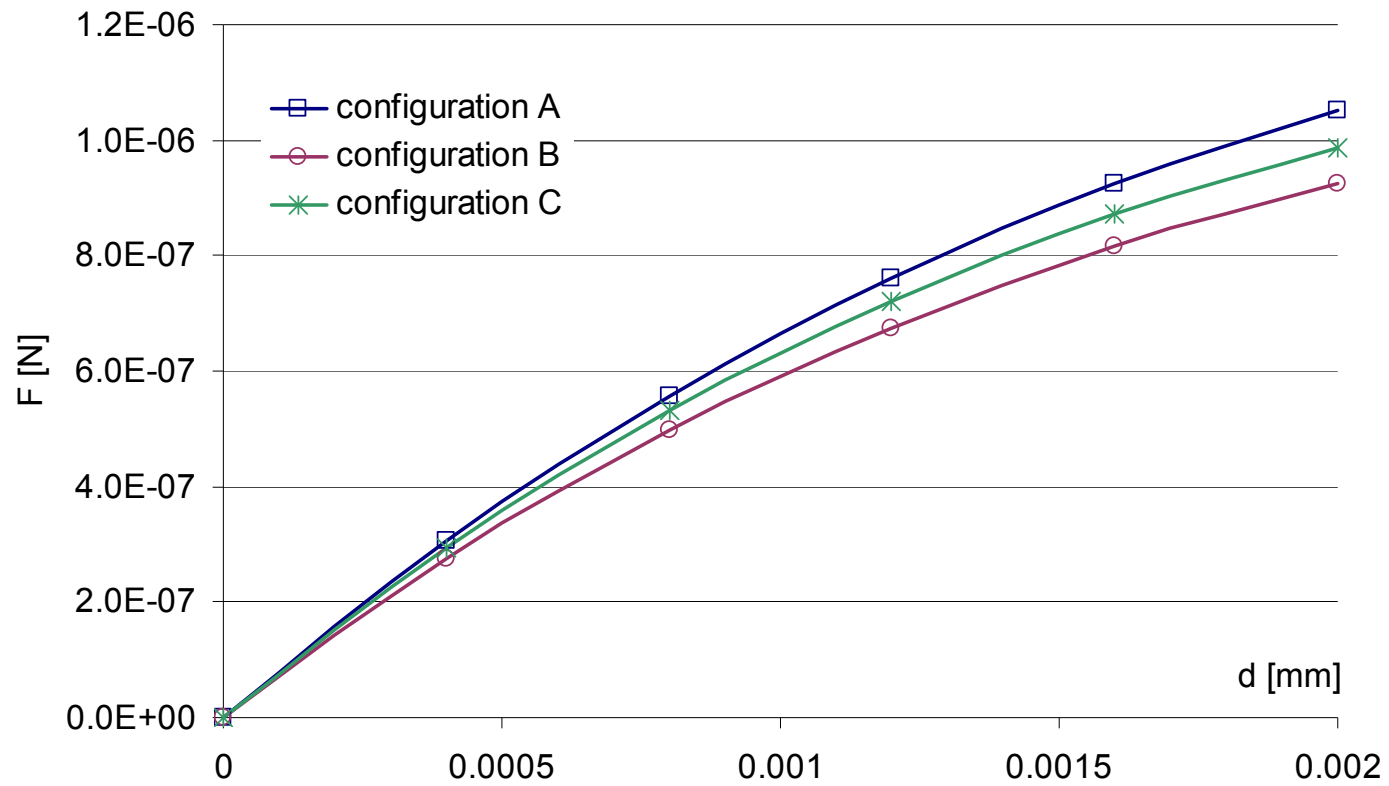
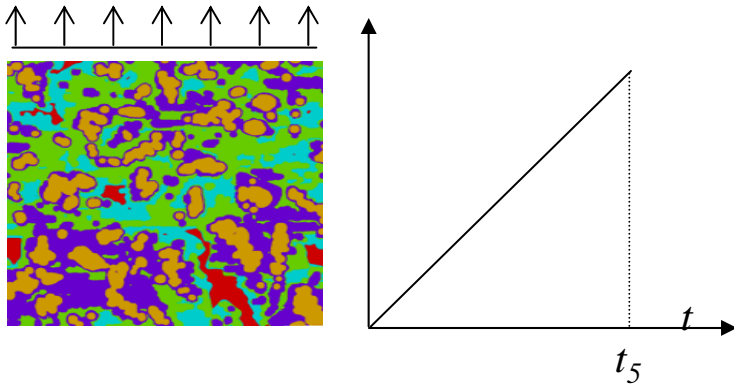

• Craze development

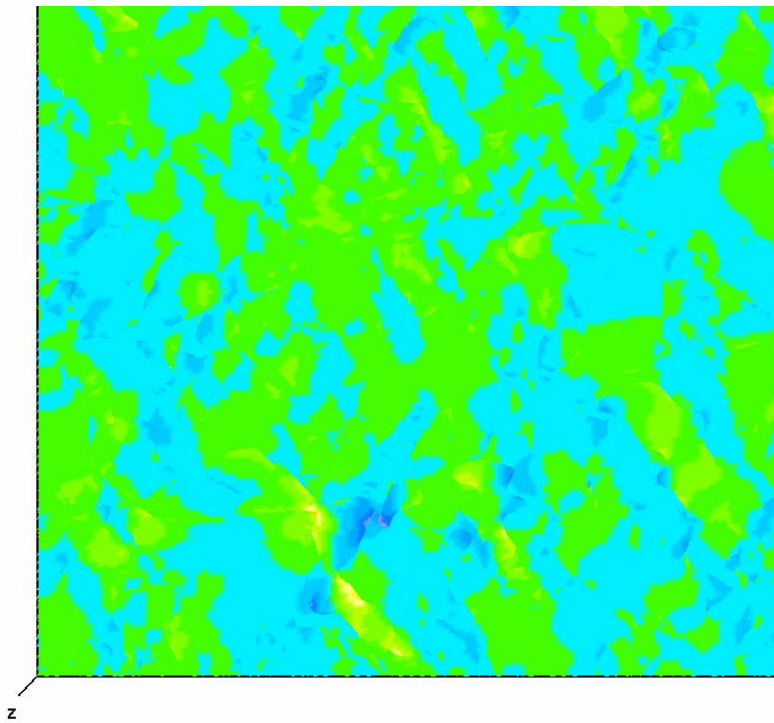
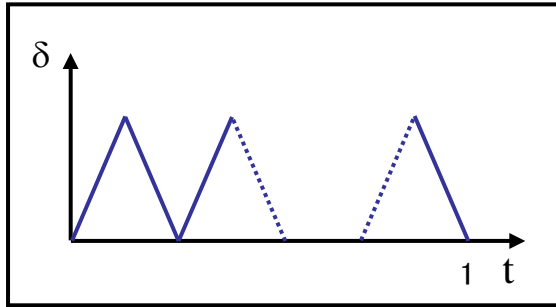

S_{12}

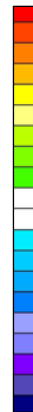

• Craze development

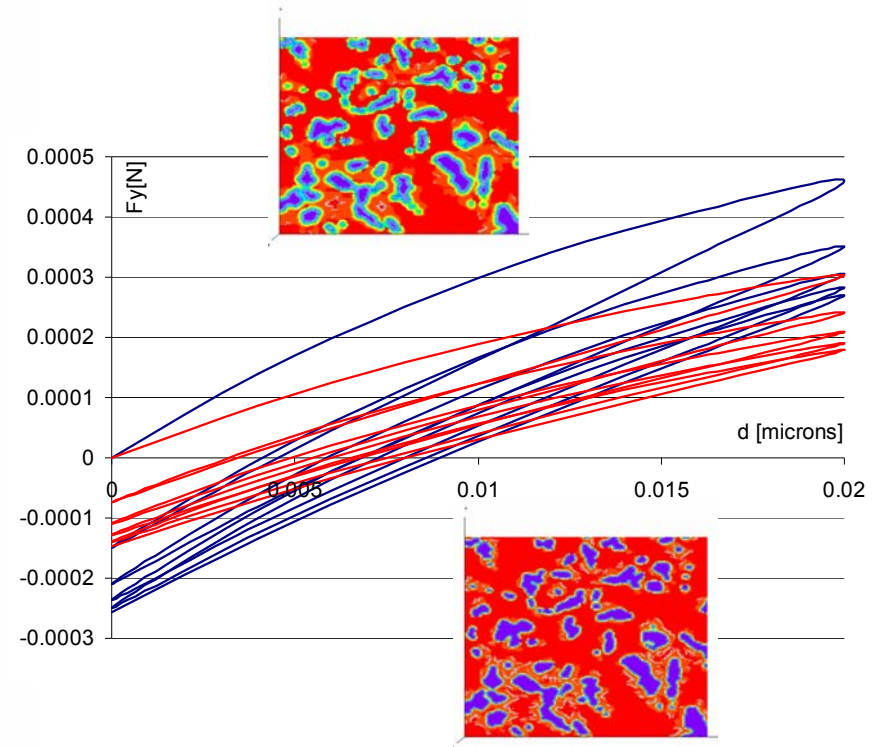
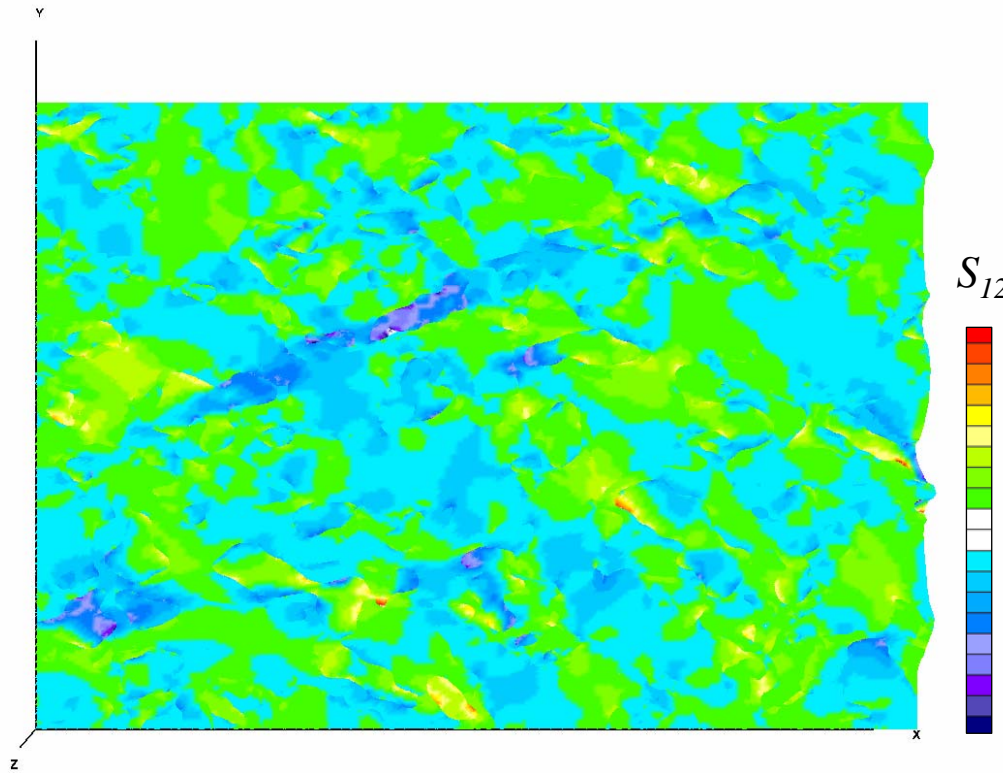
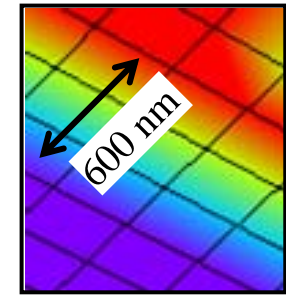
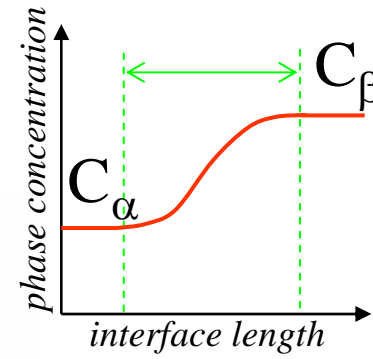
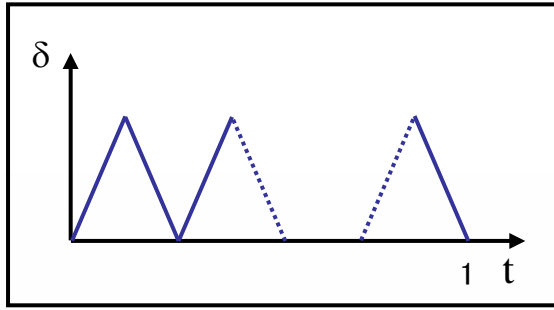

- **Crazing development**
 - **damage development with cycling**

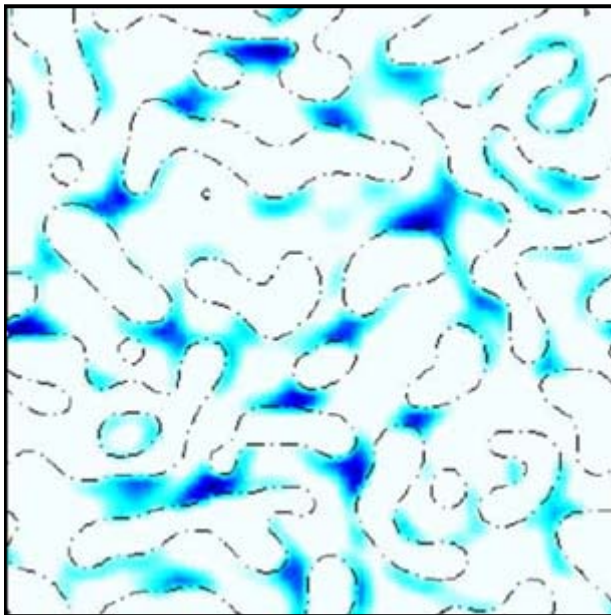

2 cycles

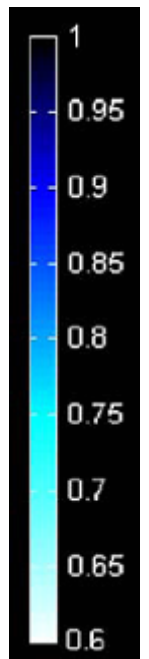

- **Crazing development**

- **damage development with cycling**

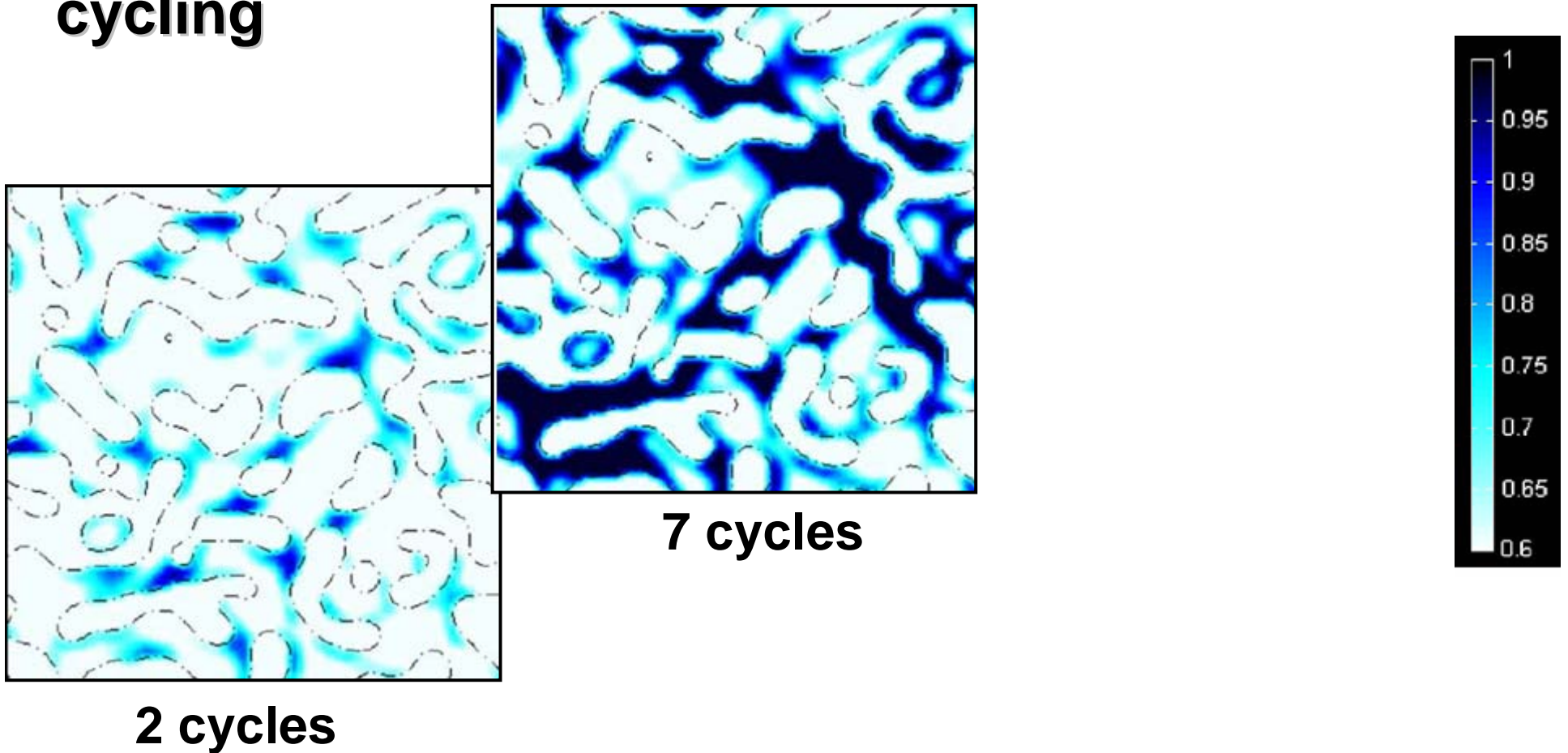

- **Crazing development**

- **damage development with cycling**

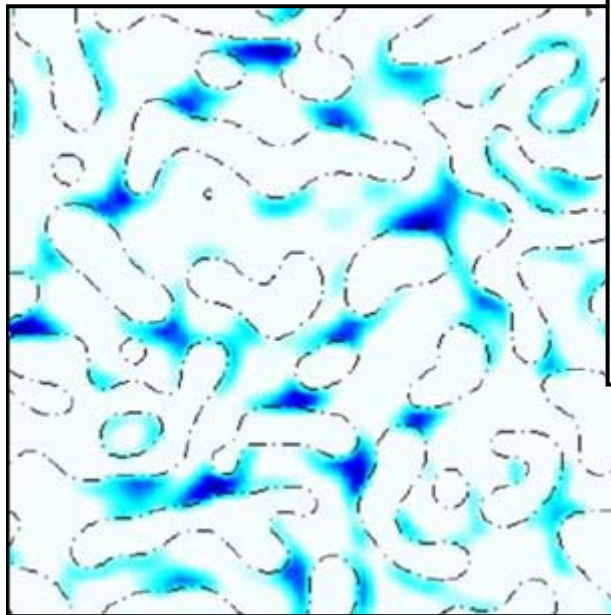

2 cycles

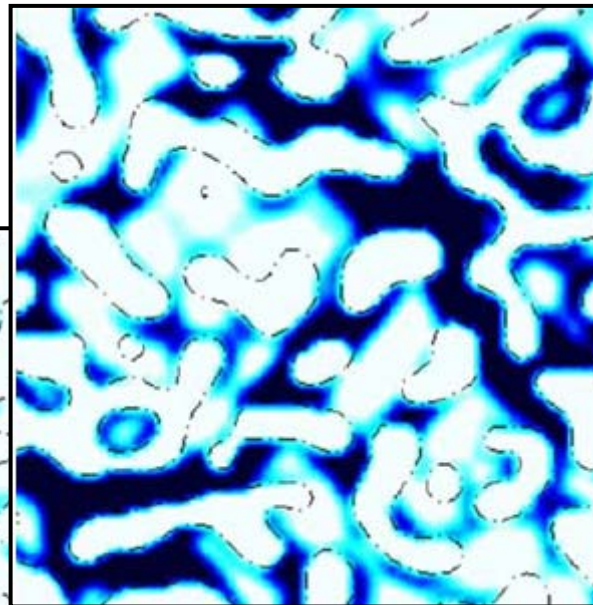

7 cycles

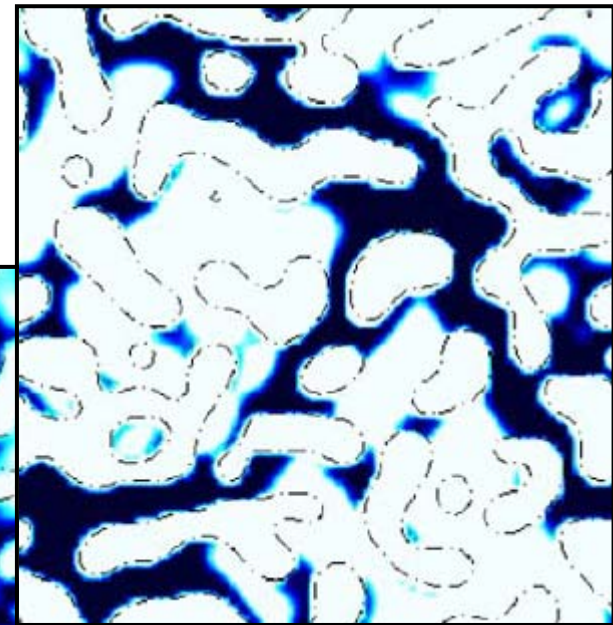

10 cycles



- **Crazing through wax boundaries**

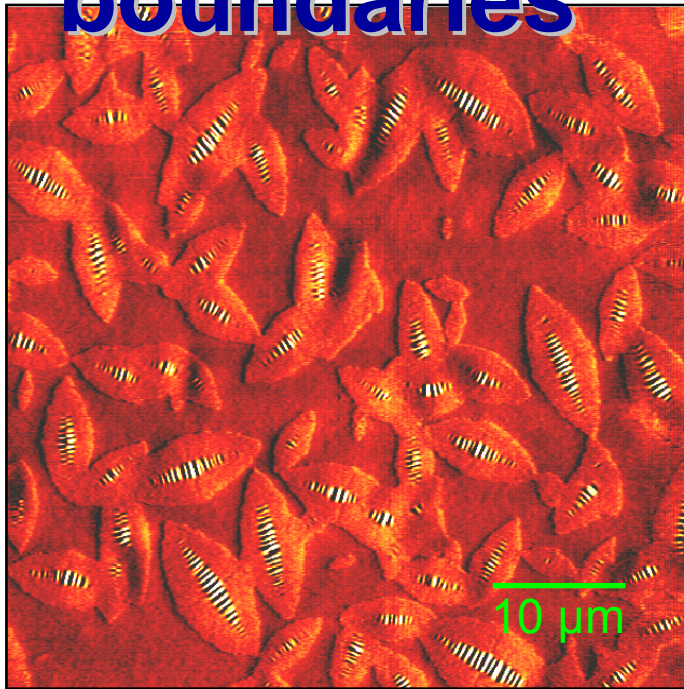

AAK-1

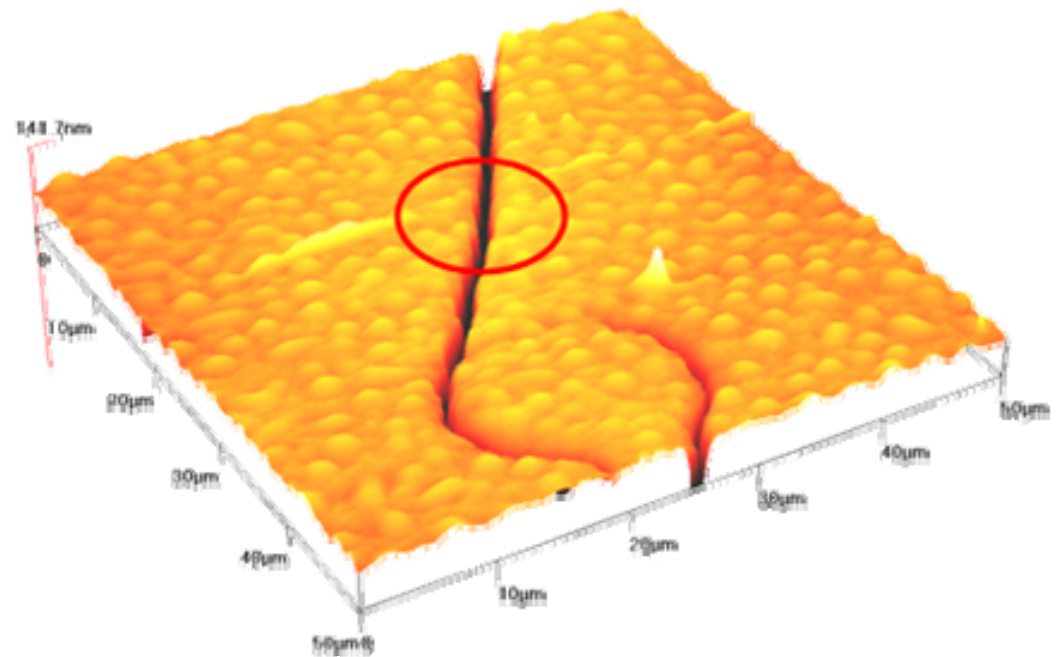

Healing
???

Mixing theory

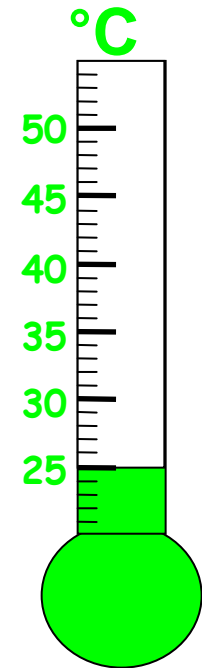
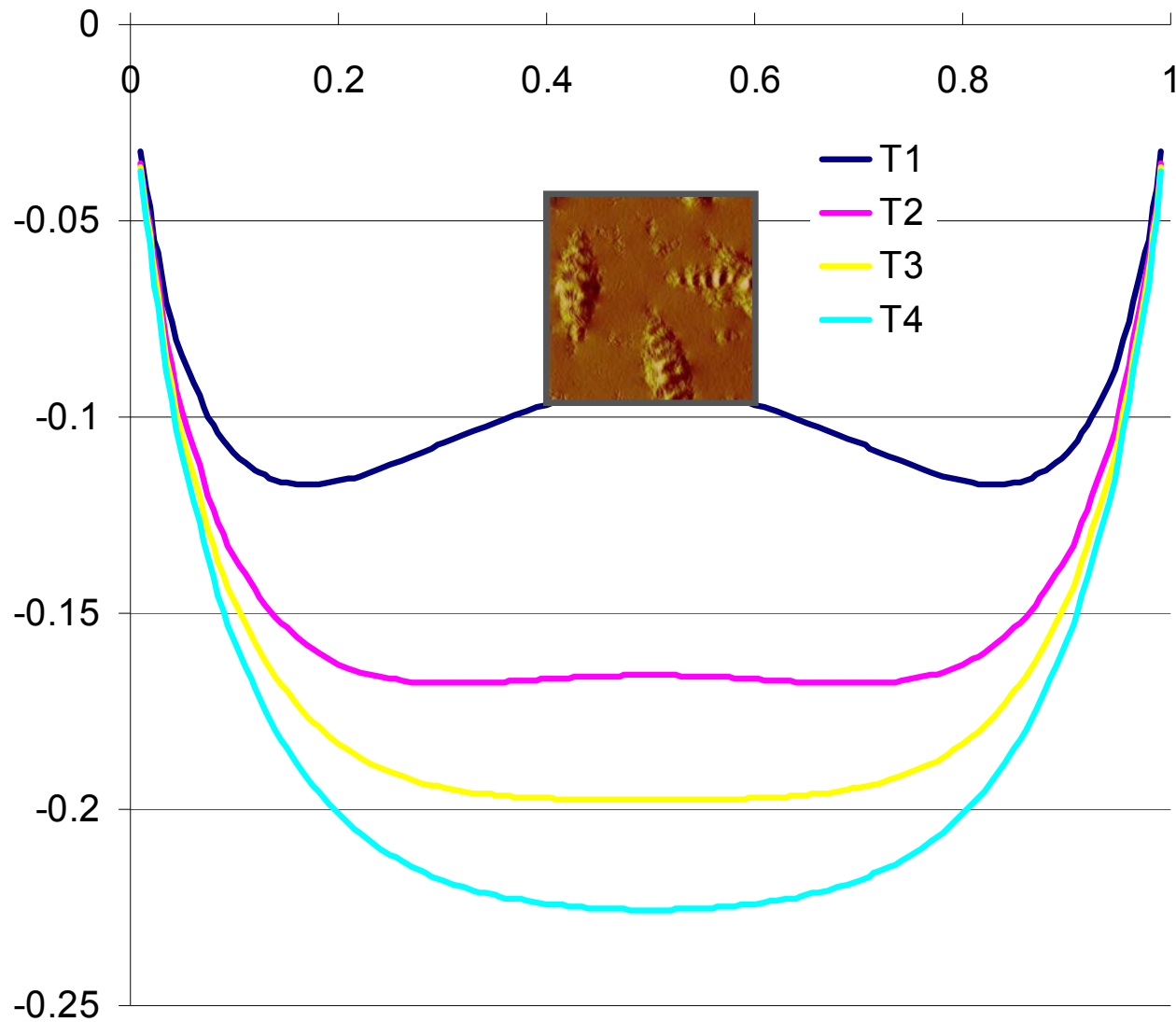

Mixing theory

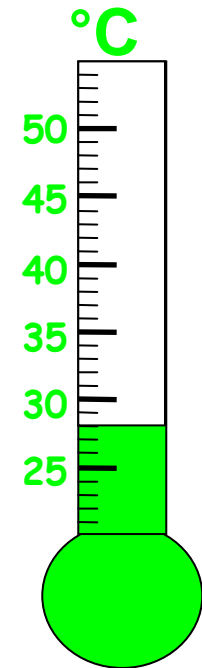
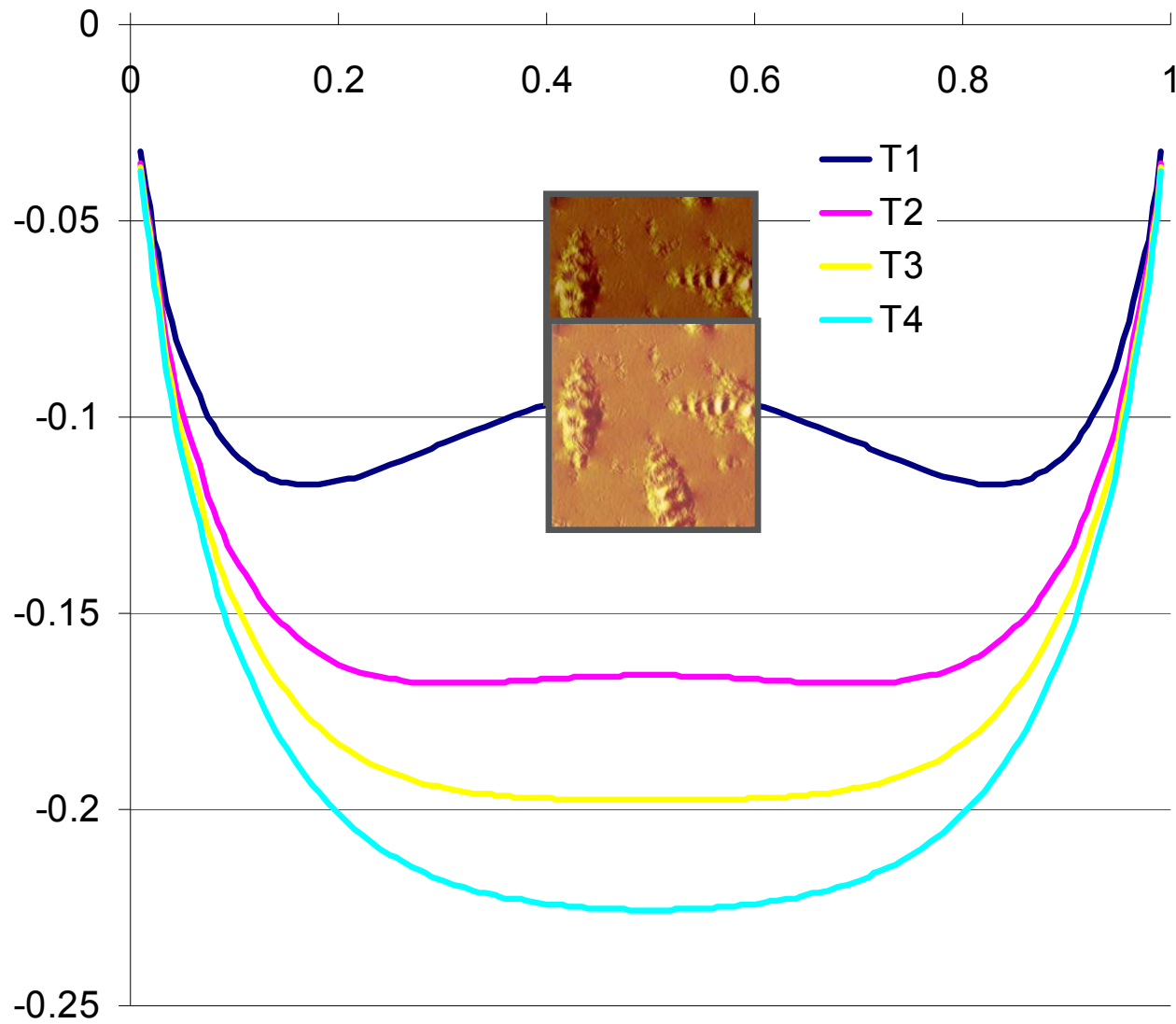

• Mixing theory

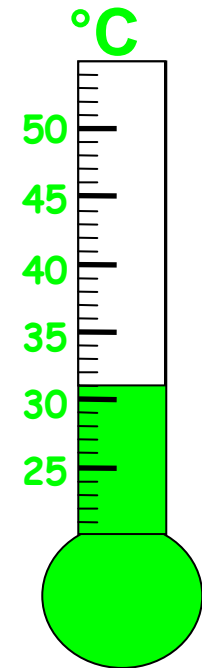
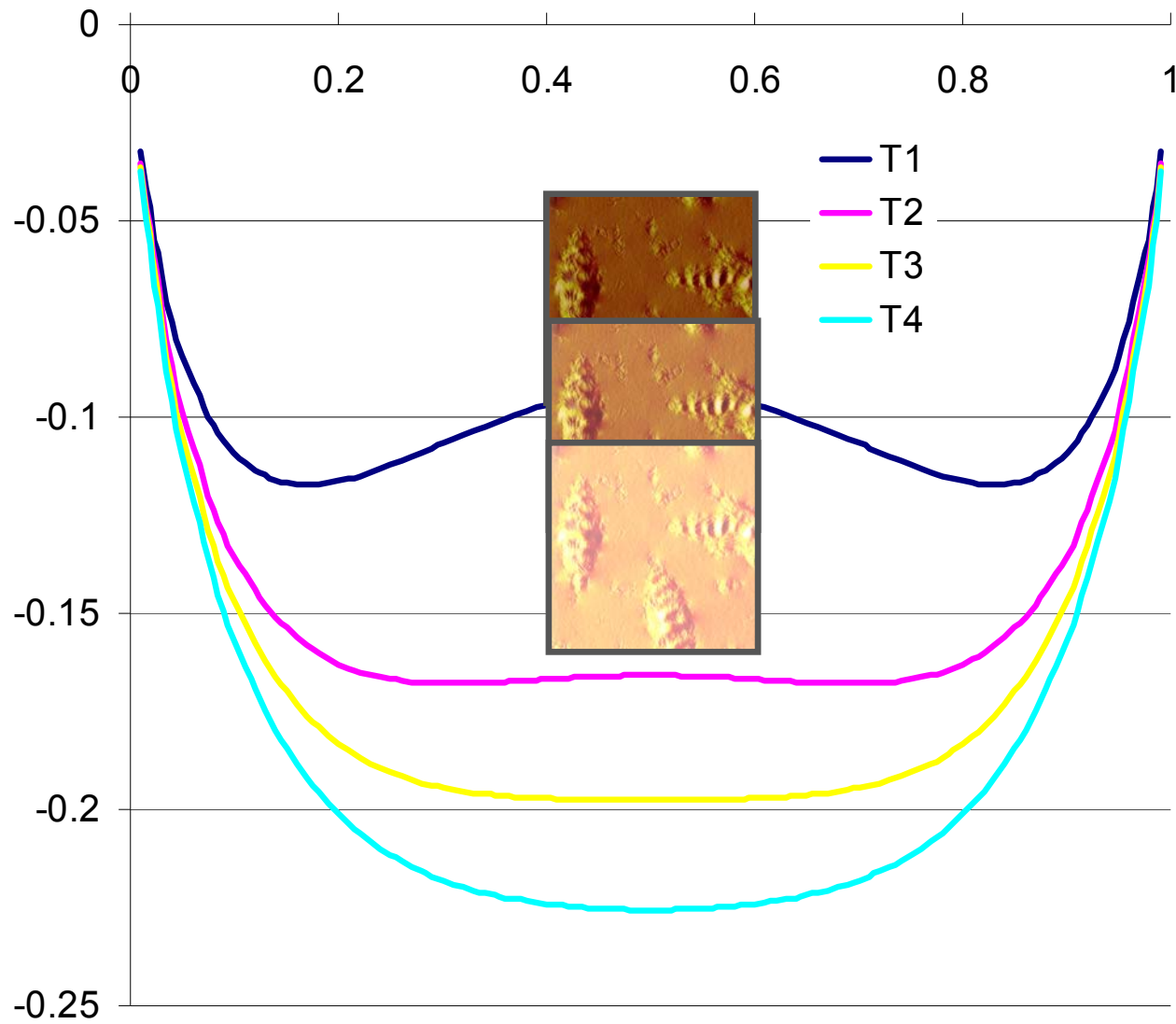

Mixing theory

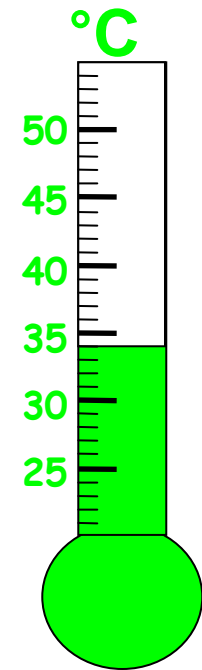
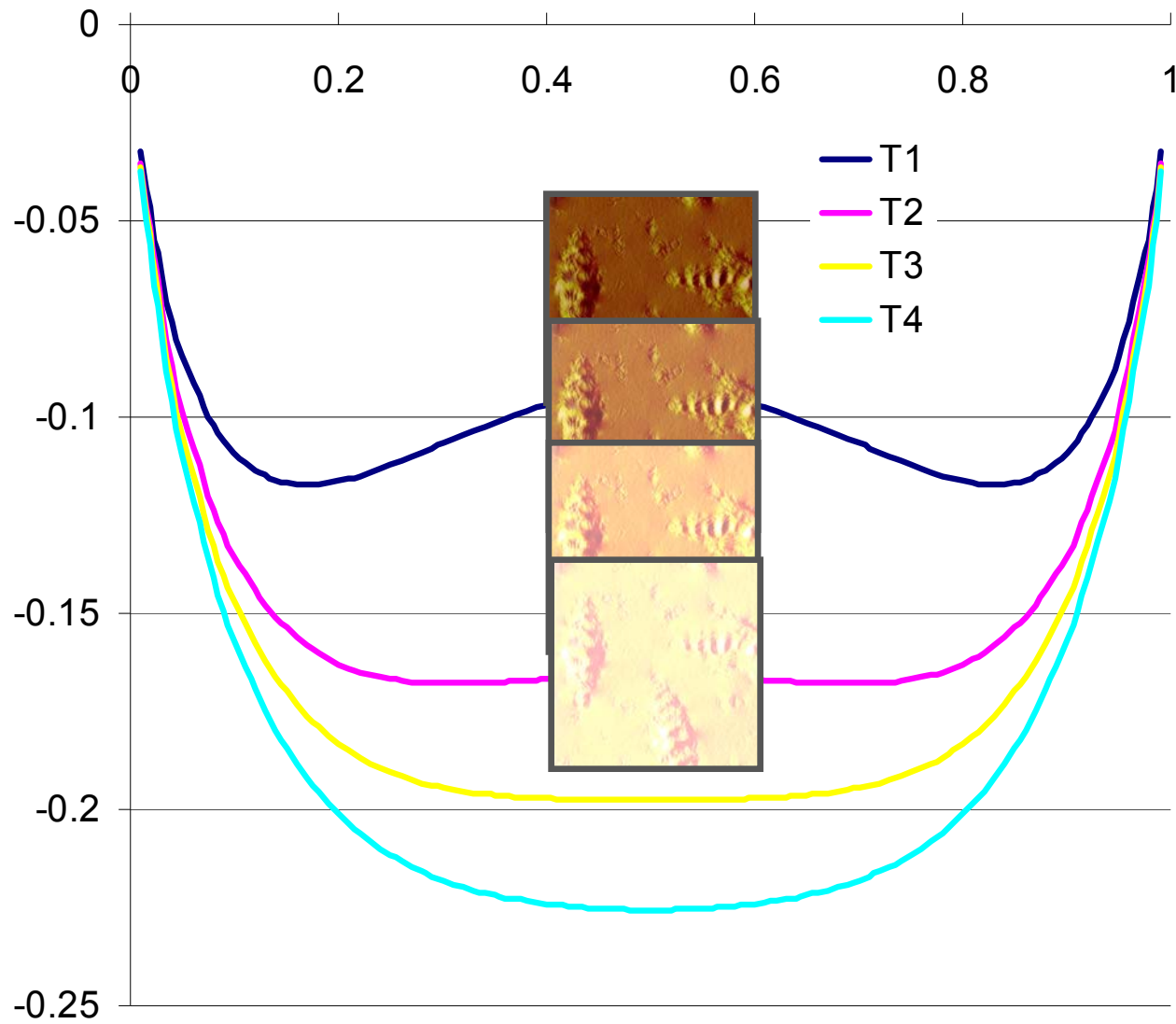

• Mixing theory

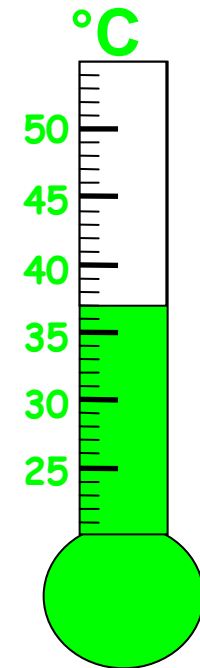
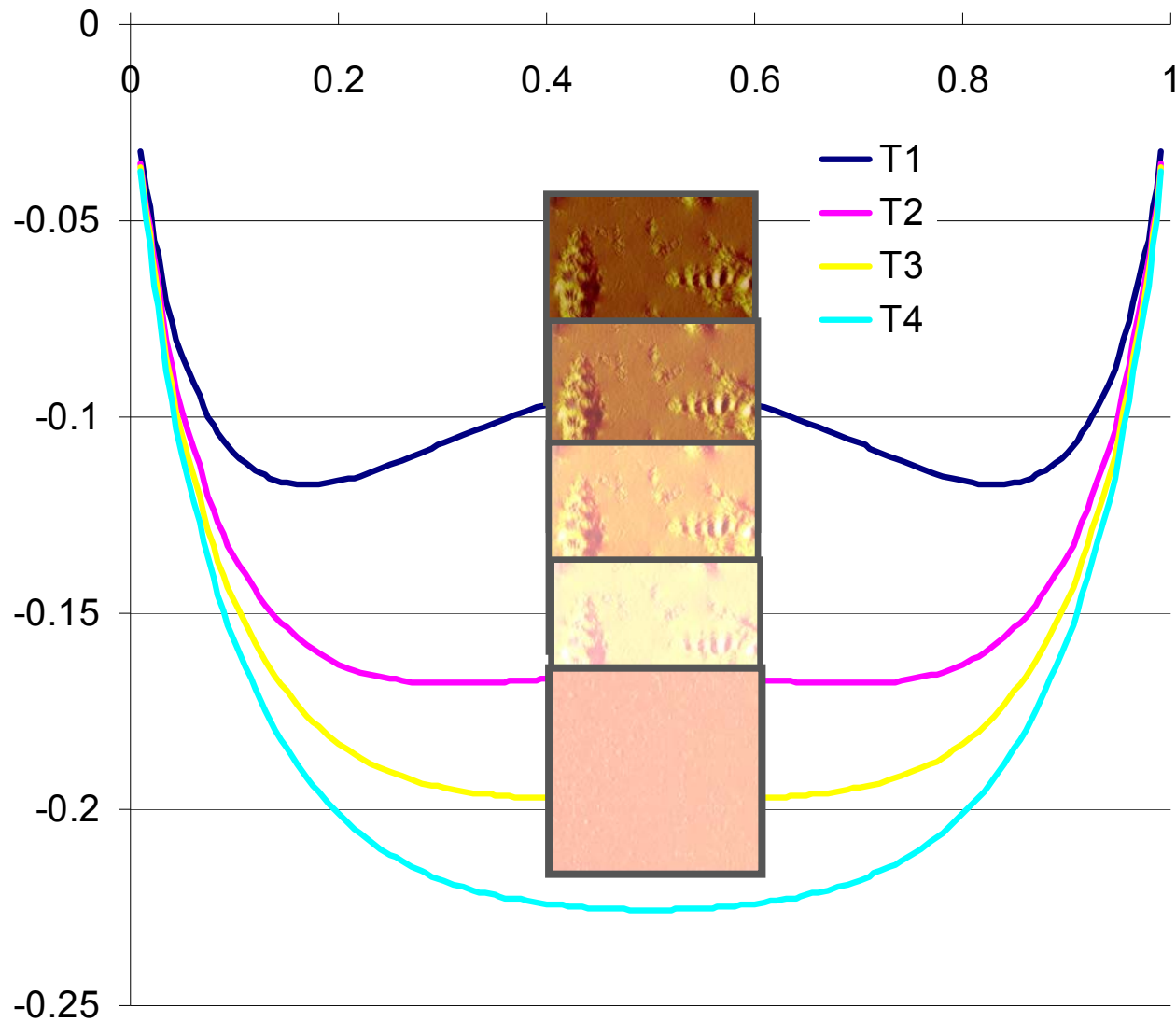

• Mixing theory

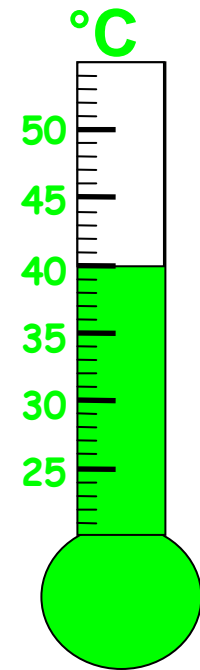
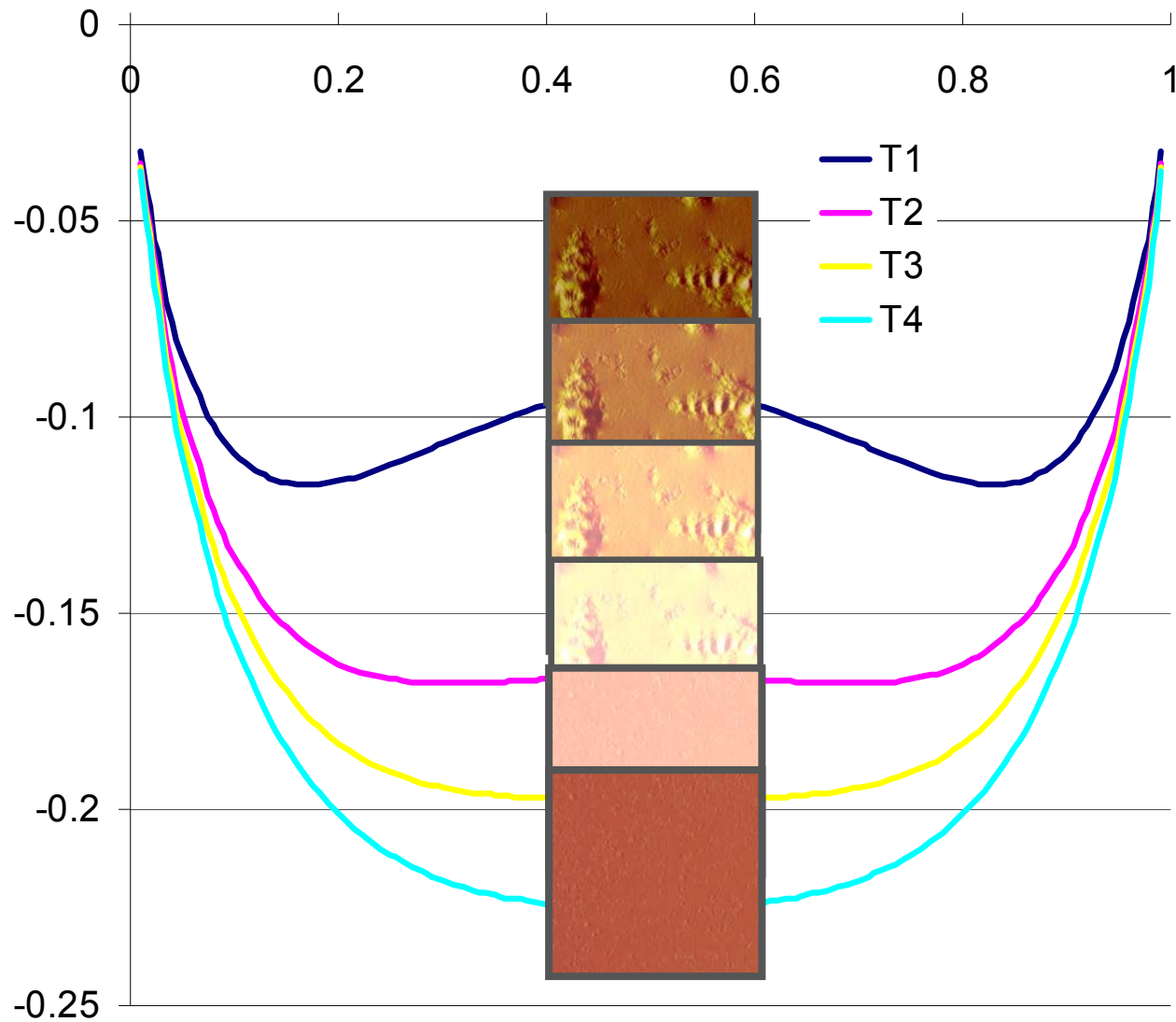

Mixing theory

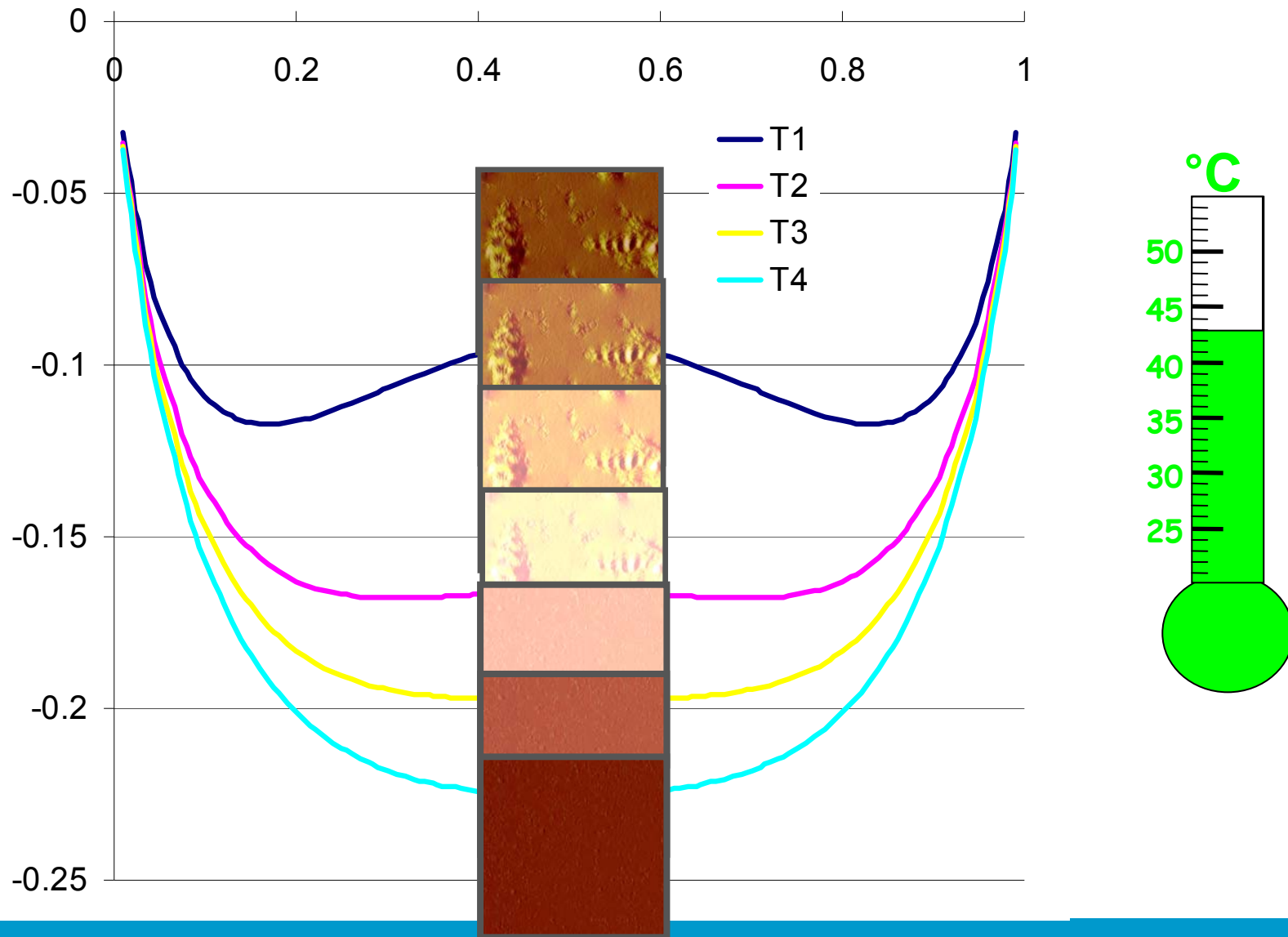

Mixing theory

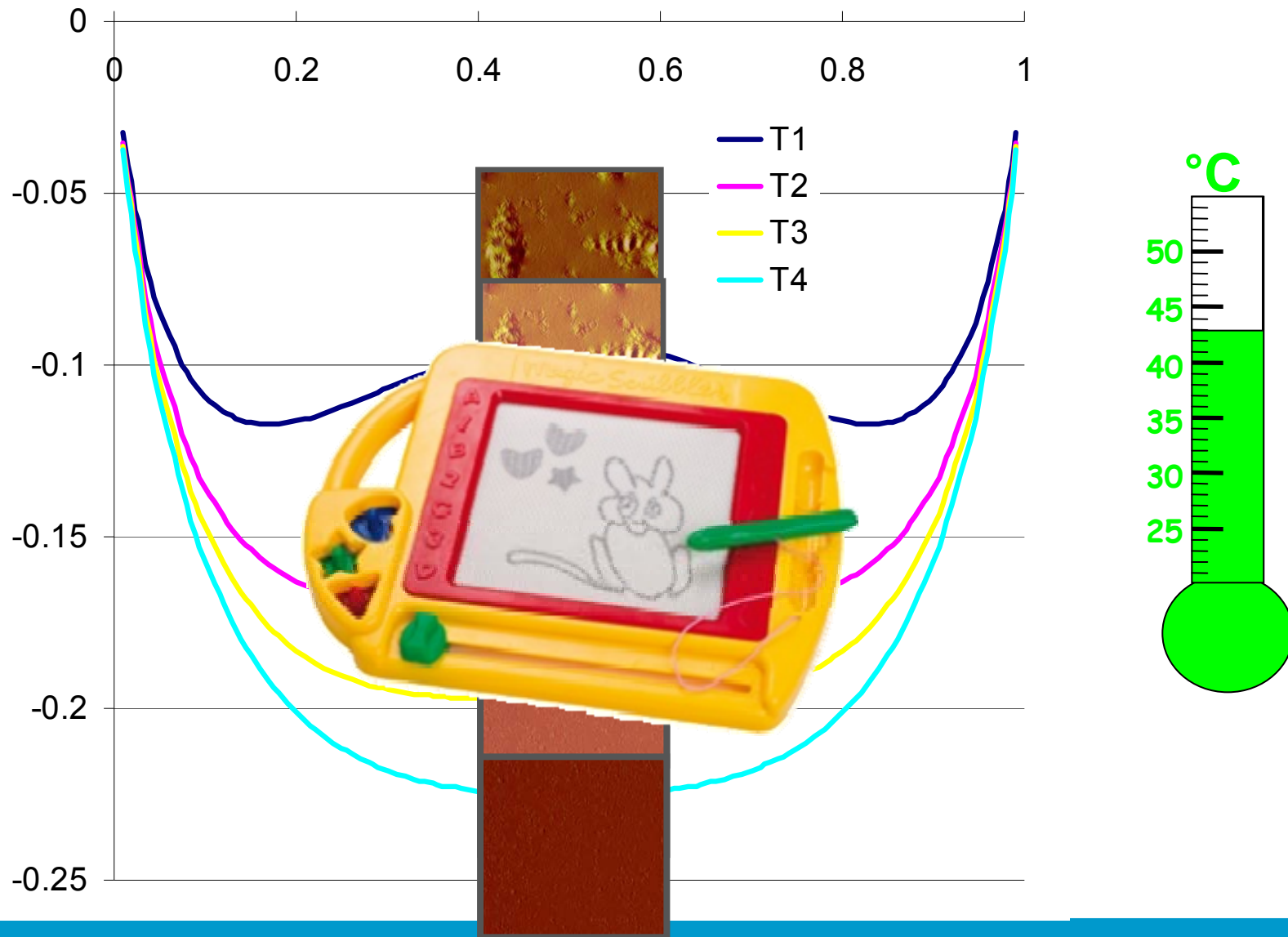

Mixing theory

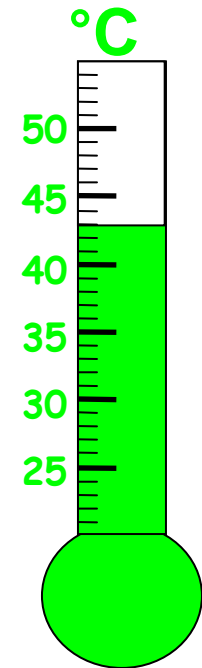
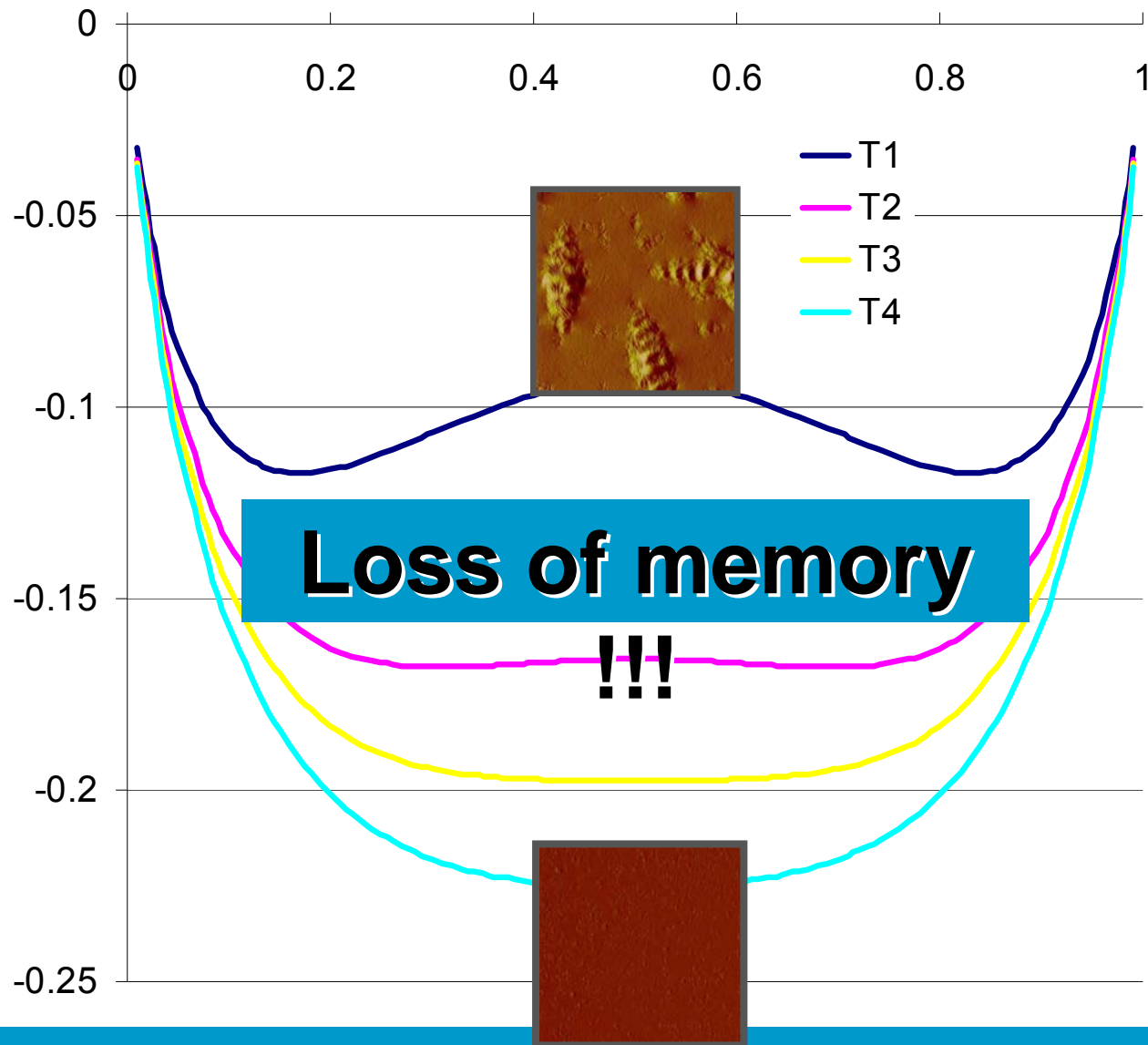

• Healing model

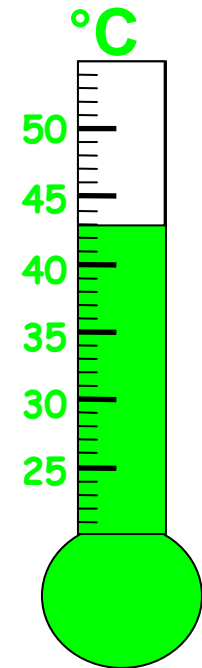
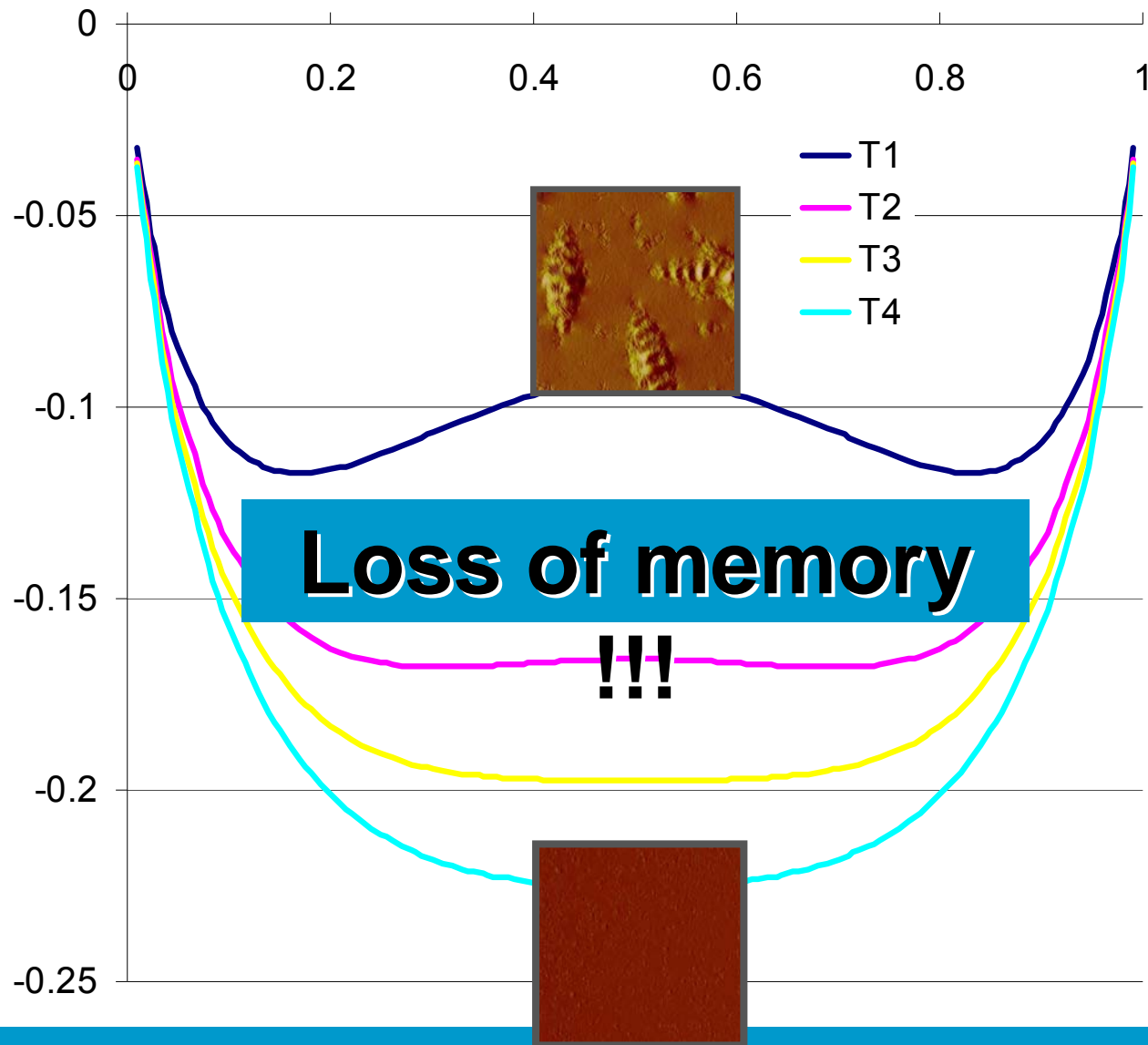

- **Healing model**

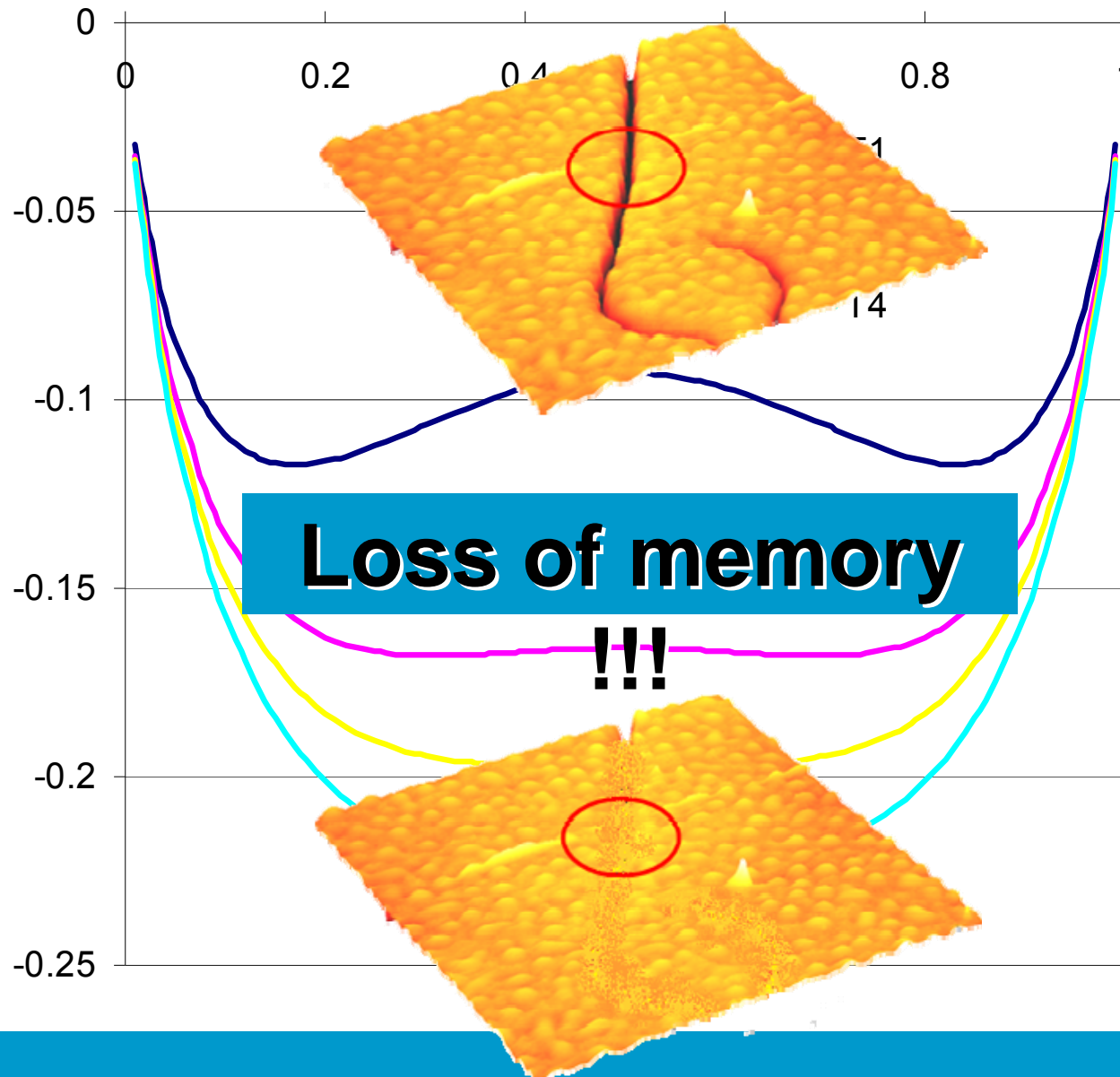

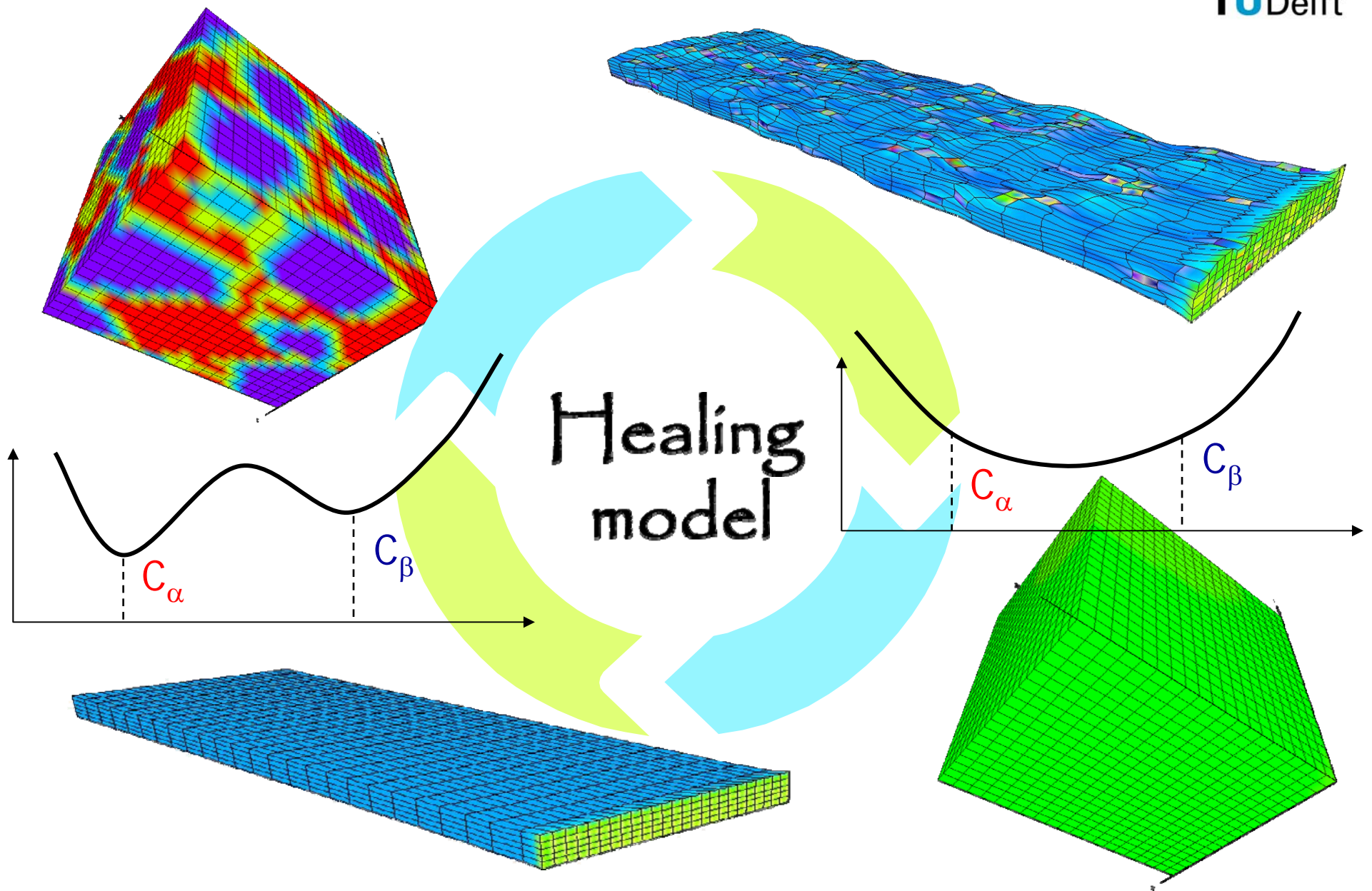

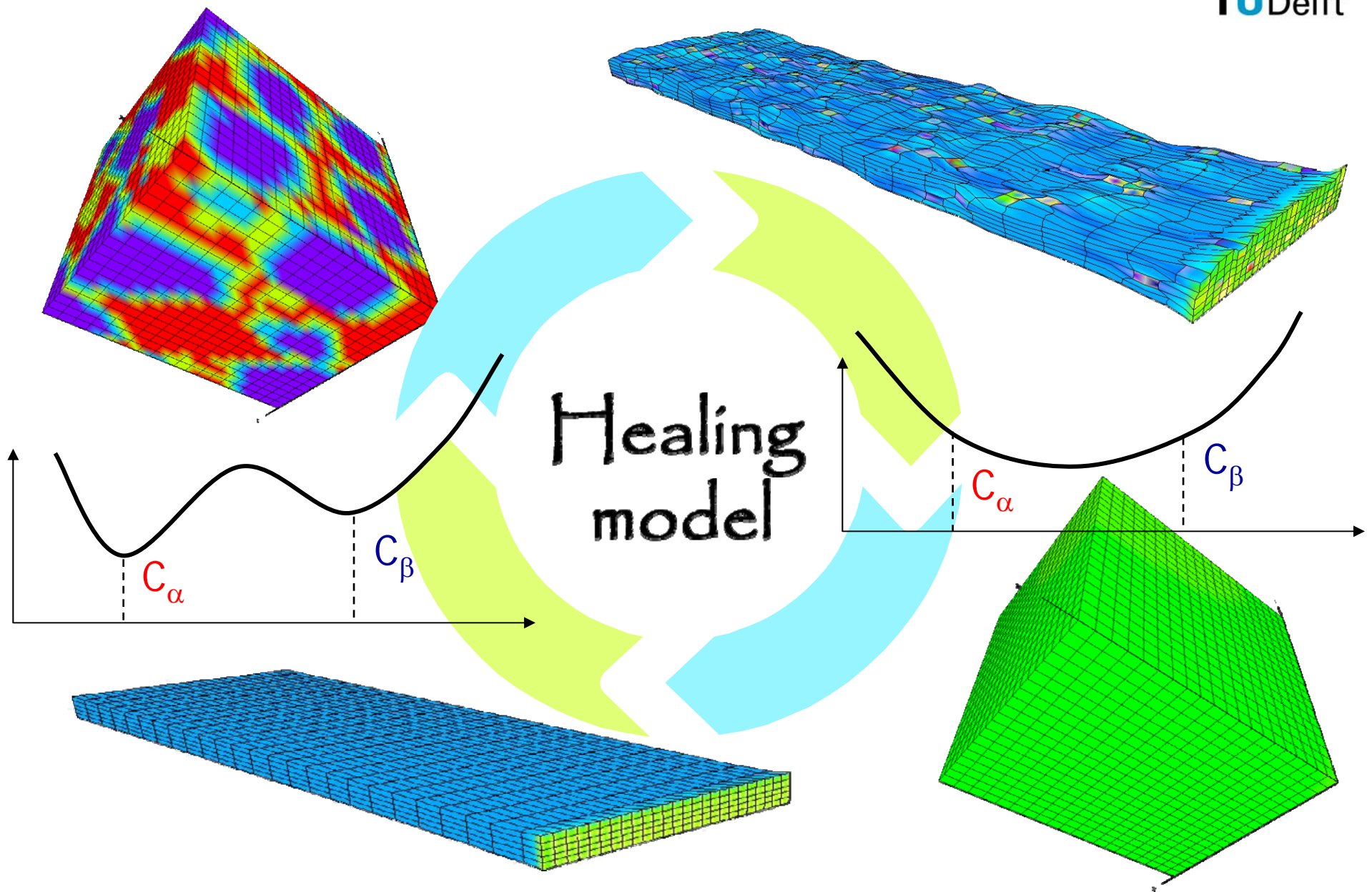

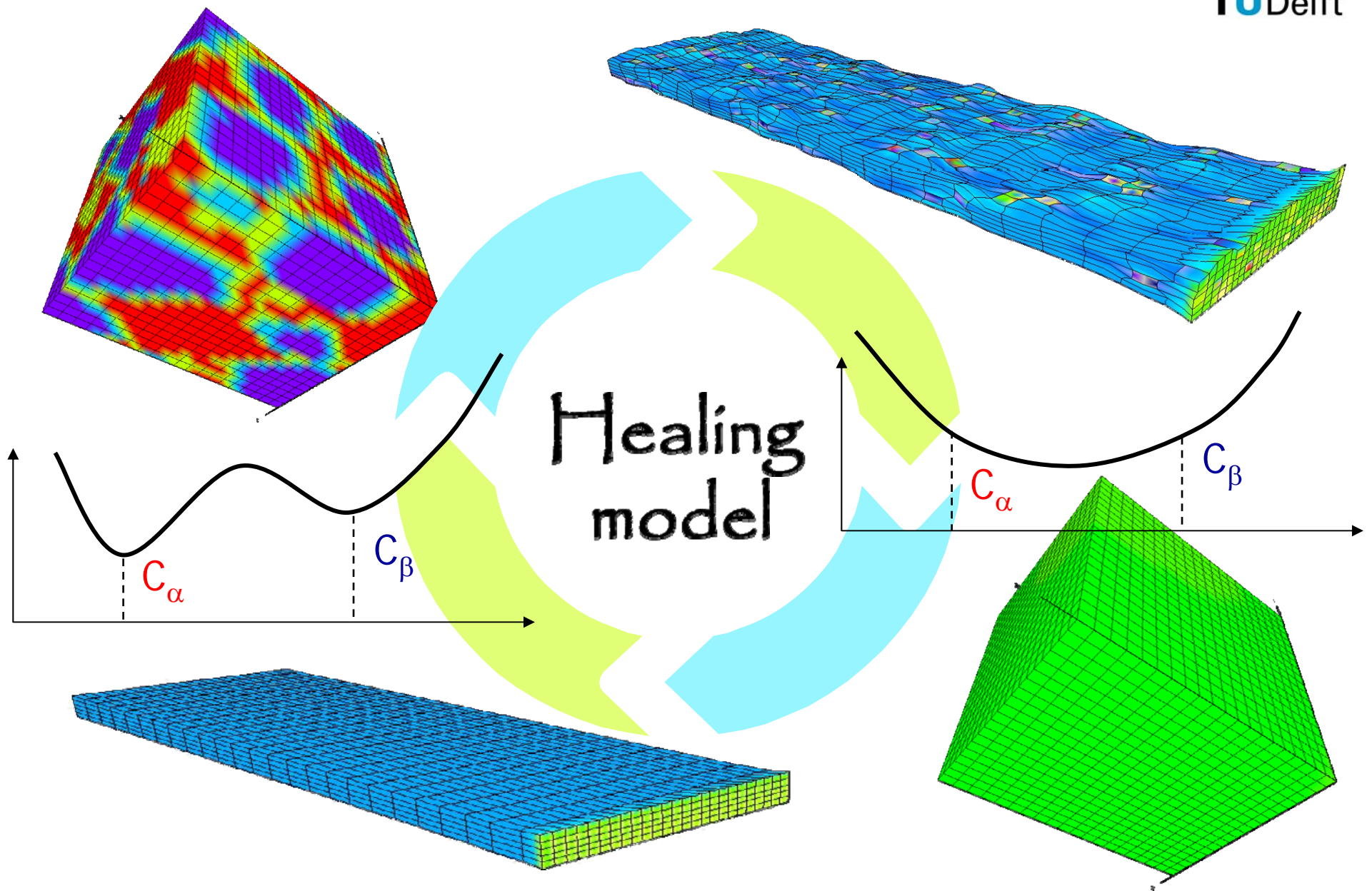

• Healing model

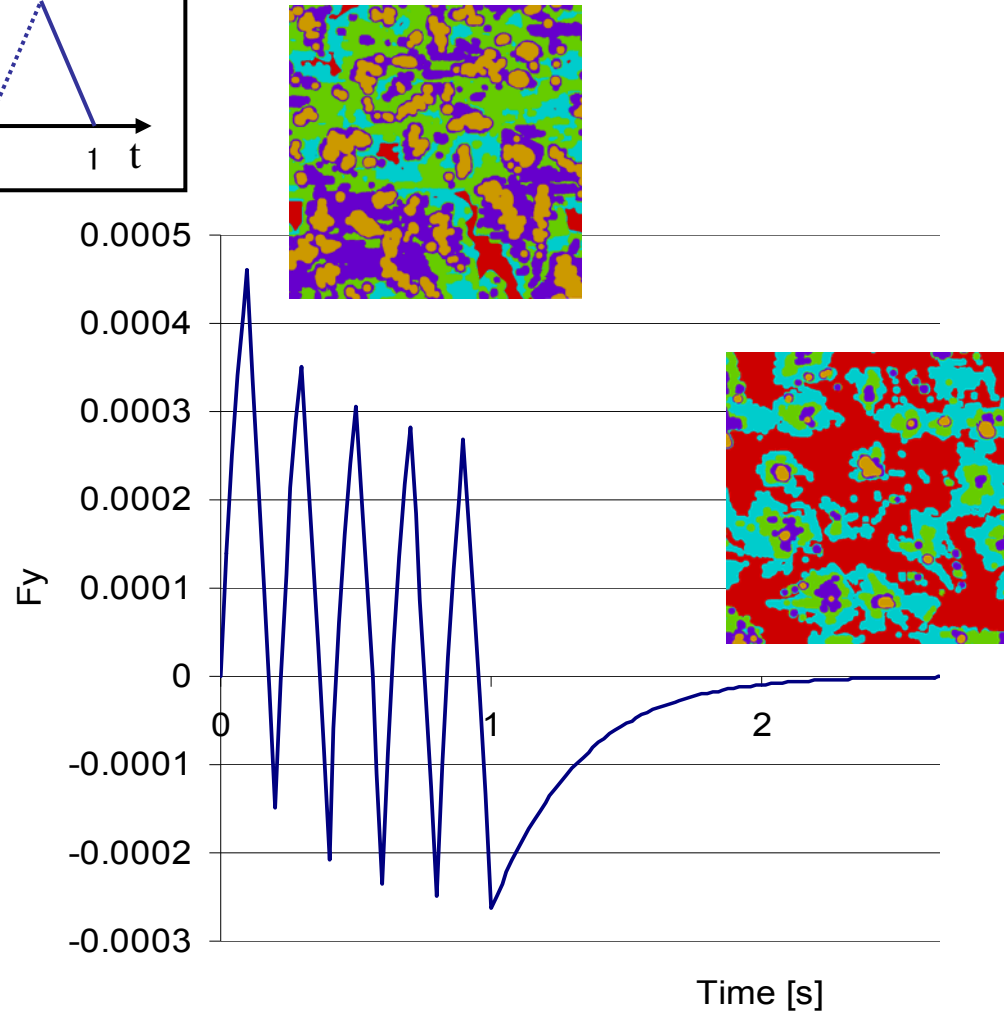
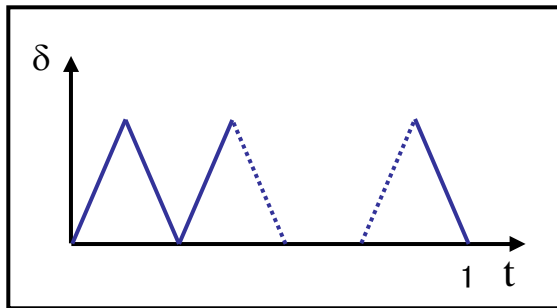

• Healing model

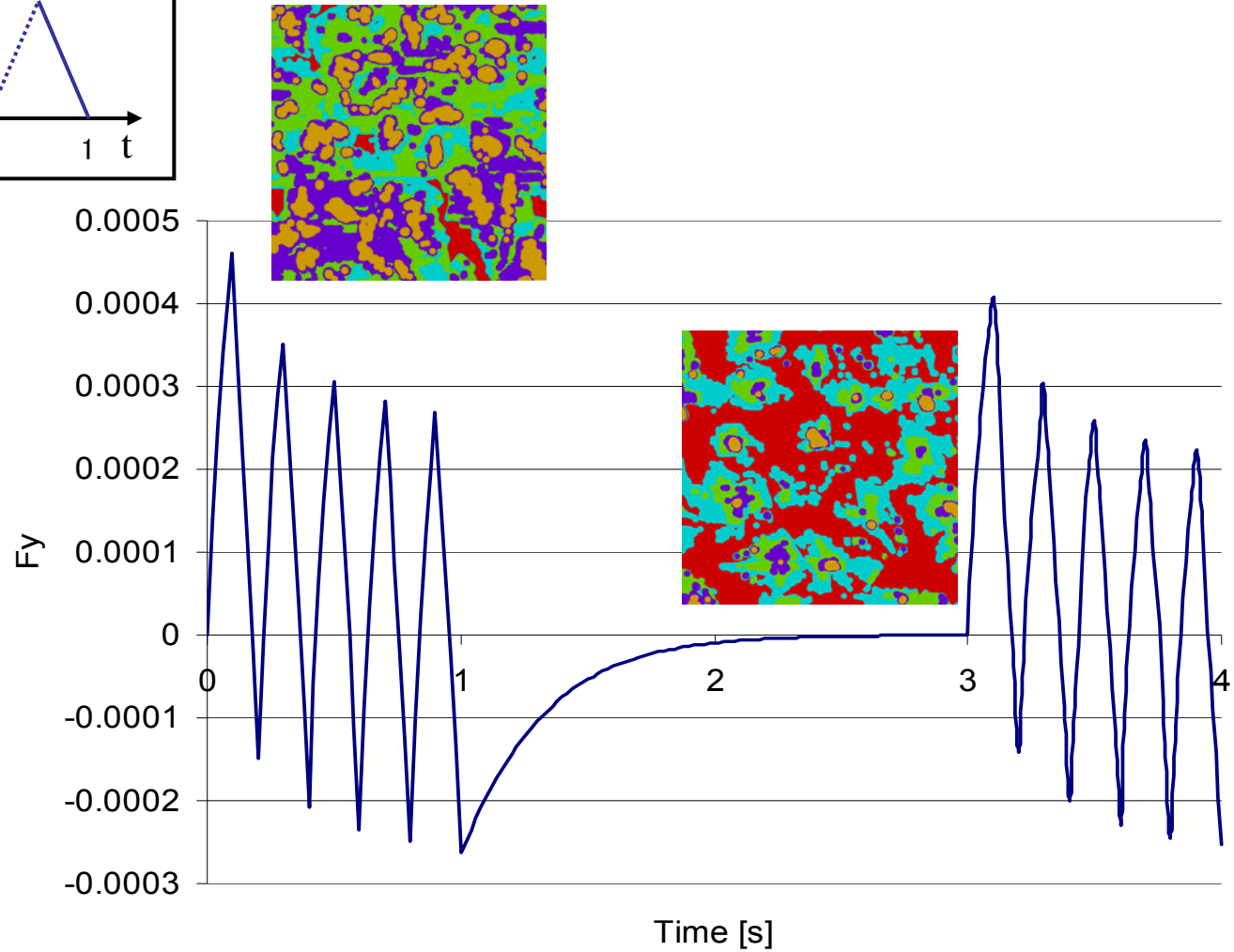
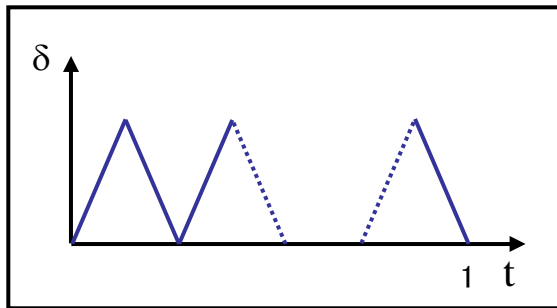

Upscaling:

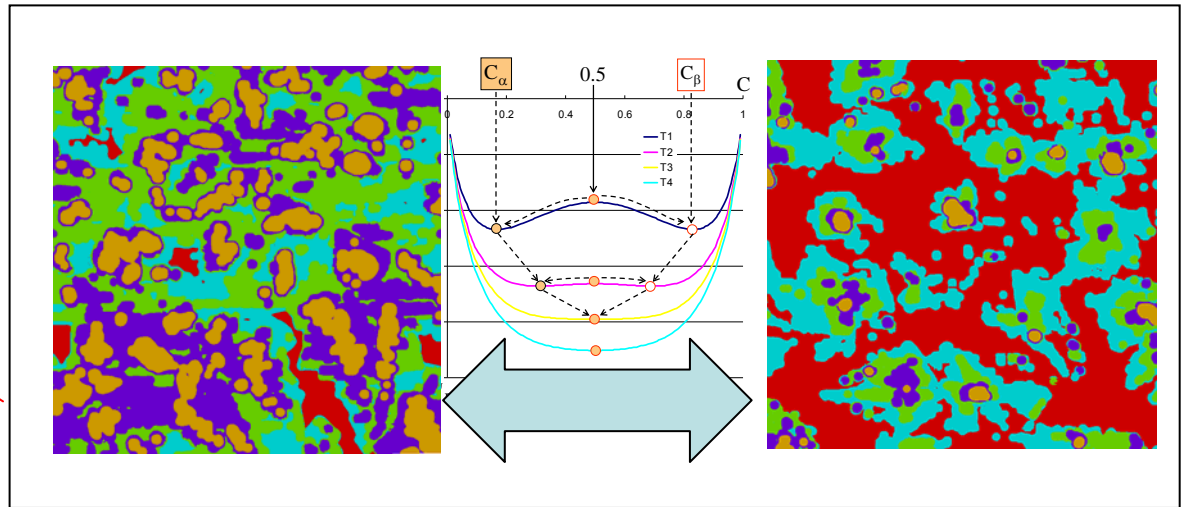
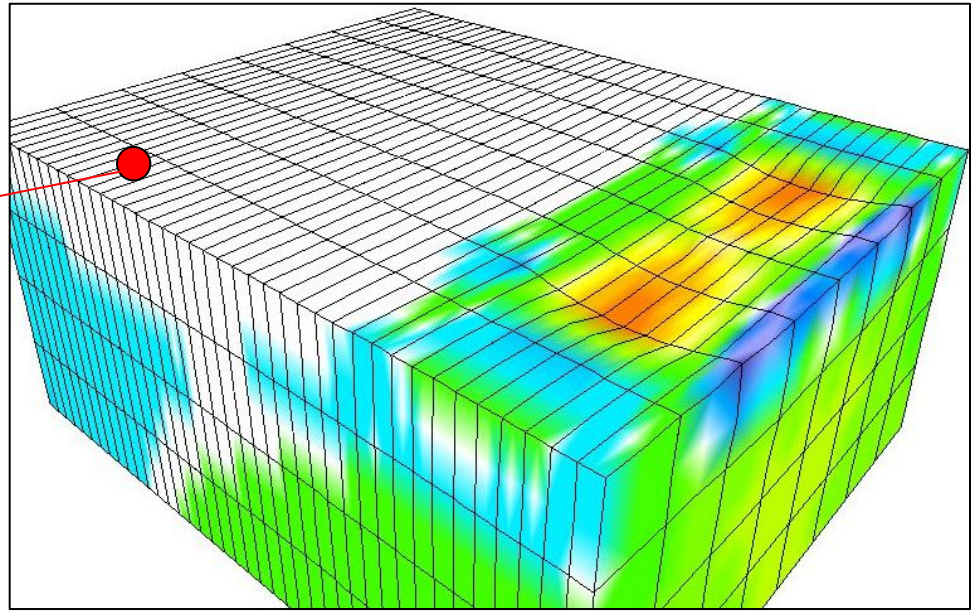
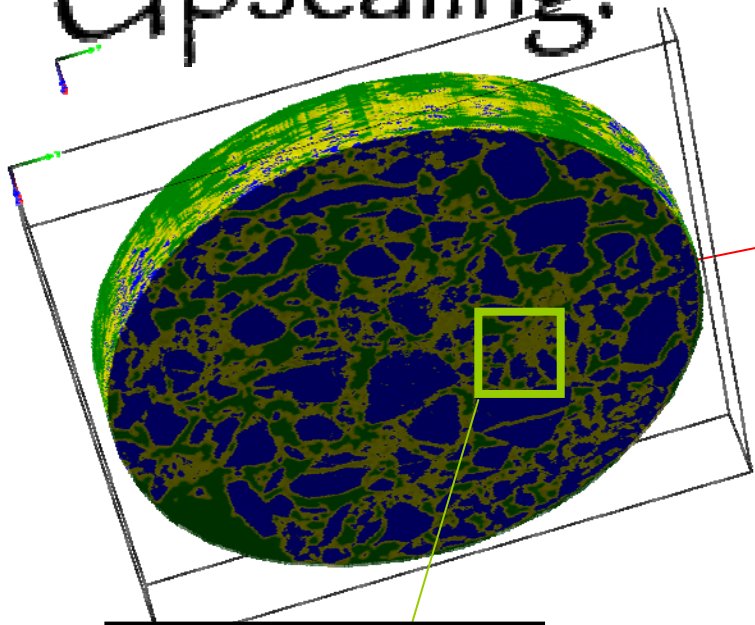

Upscaling:

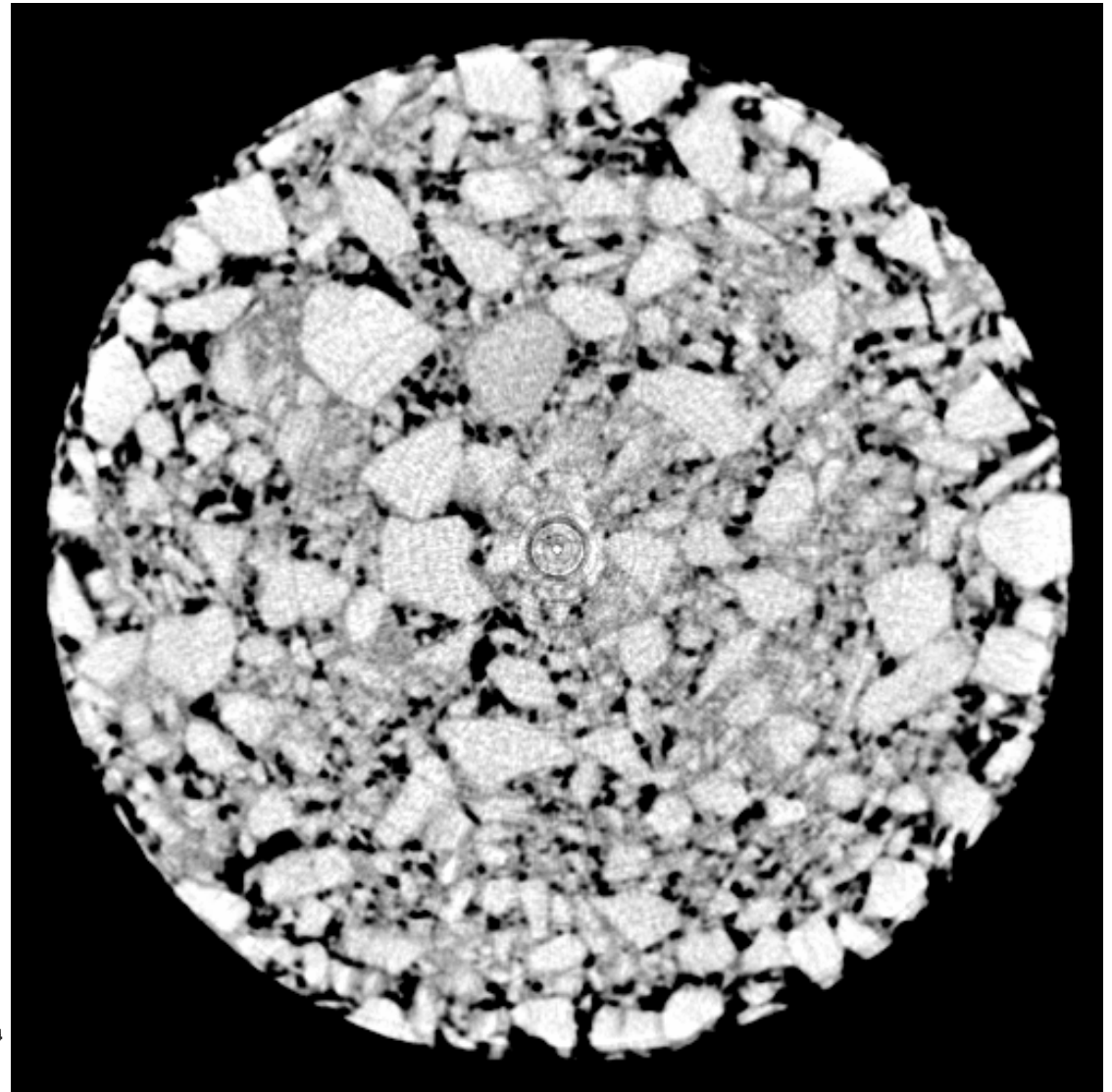
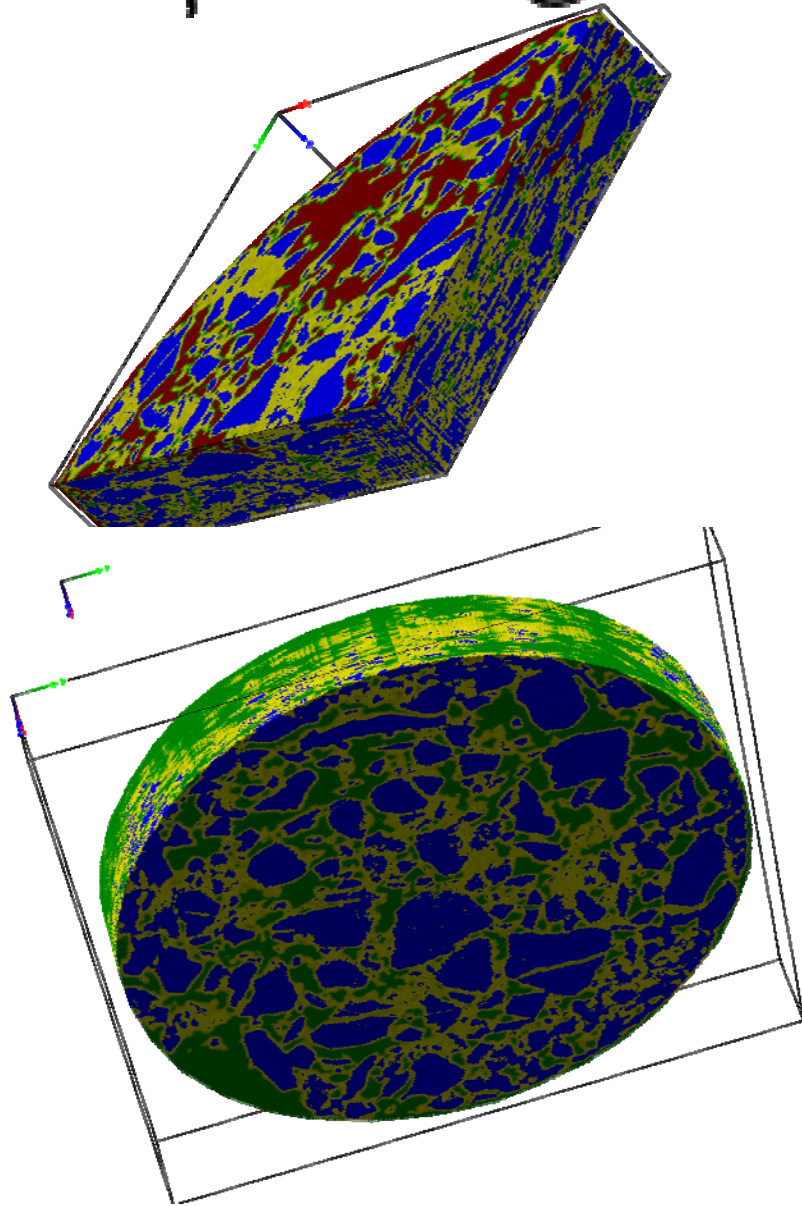

Constitutive Formulation

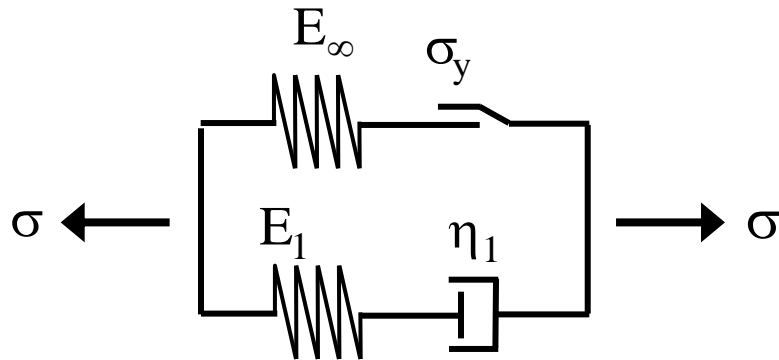

$$\mathbf{C}_\infty = \mathbf{F}_\infty^T \mathbf{F}_\infty \quad ; \quad \mathbf{C}_e = \mathbf{F}_e^T \mathbf{F}_e$$

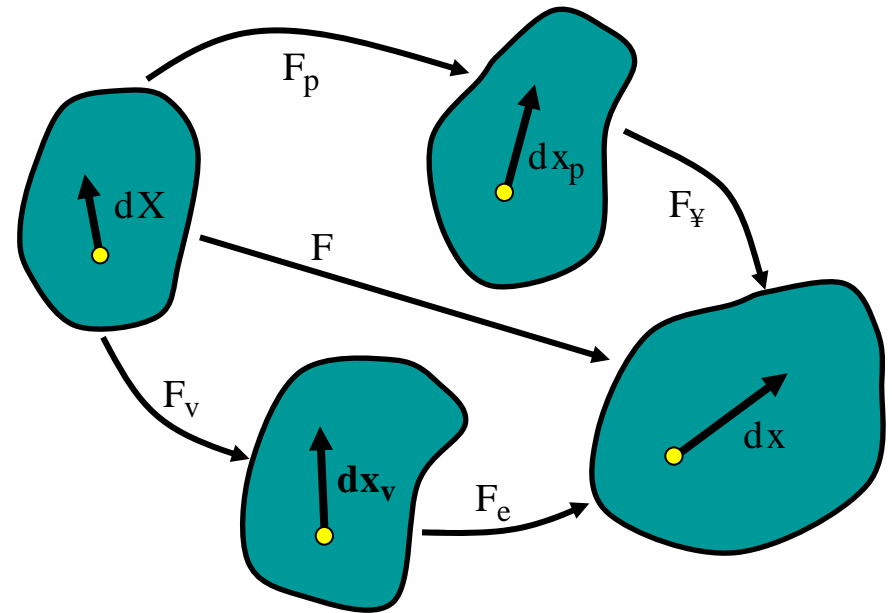

Stress tensor :

$$\begin{aligned} \mathbf{S} &= 2\mathbf{F}_v^{-1} \frac{\partial \Psi_v}{\partial \mathbf{C}_e} \mathbf{F}_v^{-T} + 2\mathbf{F}_p^{-1} \frac{\partial \Psi_p}{\partial \mathbf{C}_\infty} \mathbf{F}_p^{-T} \\ &= \mathbf{S}_e + \mathbf{S}_\infty \end{aligned}$$

$$\Psi = \Psi_v + \Psi_p$$

Helmholtz free energy function

Constitutive Formulation

- Elastic material

$$\Psi_e = \Psi_e(\mathbf{C})$$

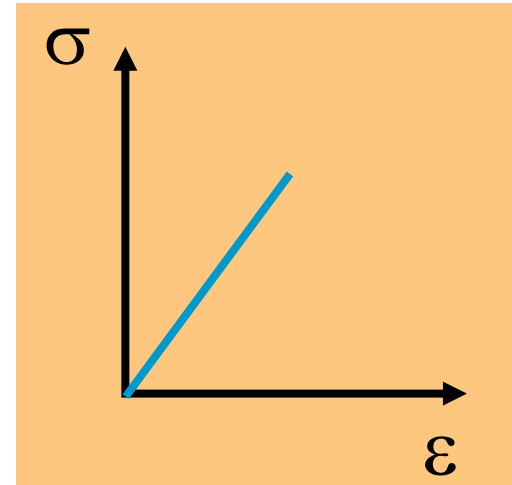

Constitutive Formulation

- Elastic material

$$\Psi_e = \Psi_e(\mathbf{C})$$

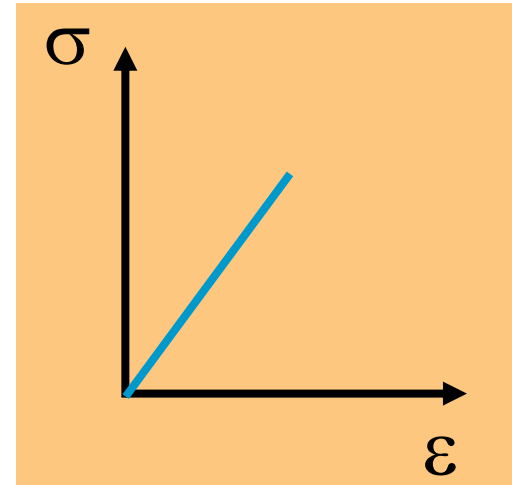

- In-elastic material

$$\Psi_p = \Psi_p(\mathbf{C}_\infty, \xi_p)$$

internal variable

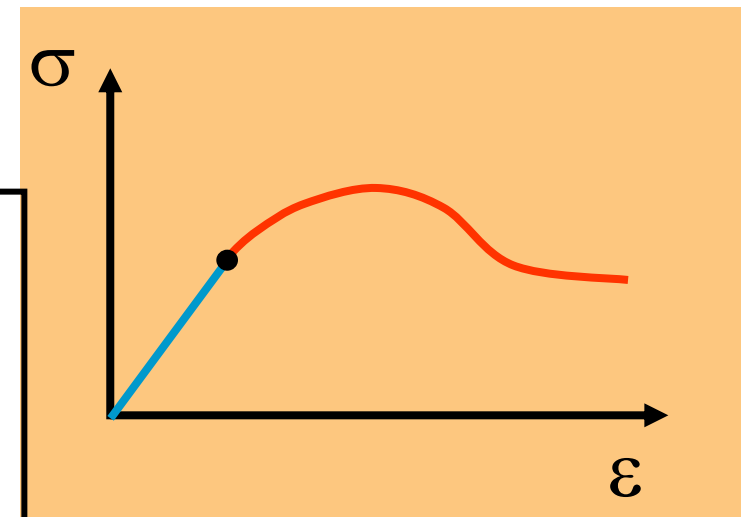
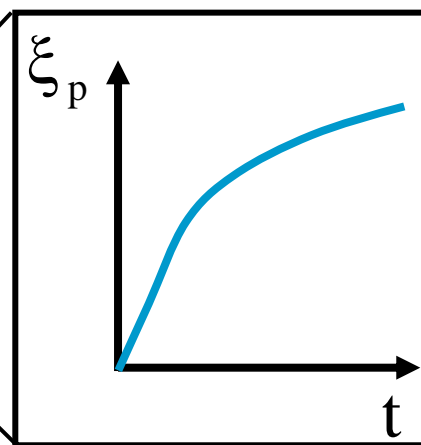

- In-elastic

material

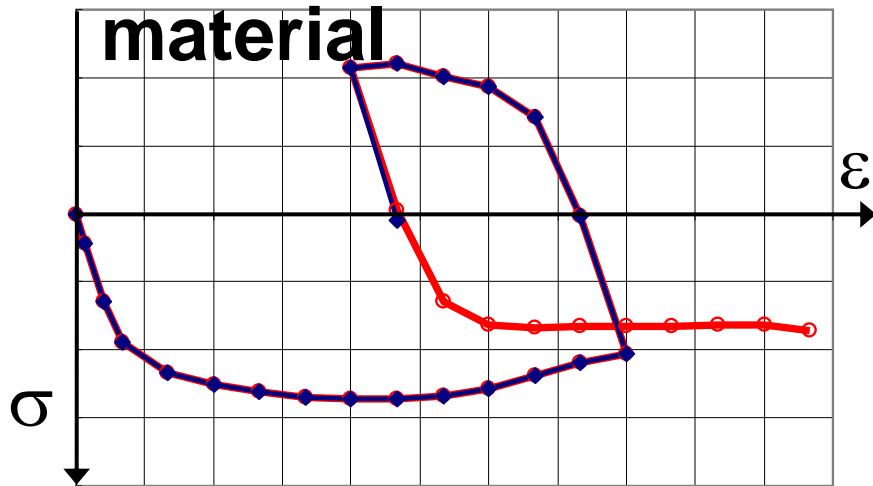

$$\Psi_p = \Psi_p (\mathbf{C}_\infty, \xi_p)$$

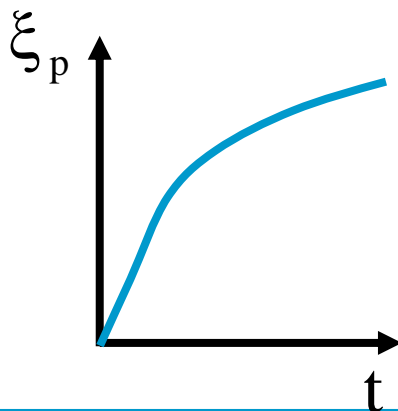

- In-elastic material**

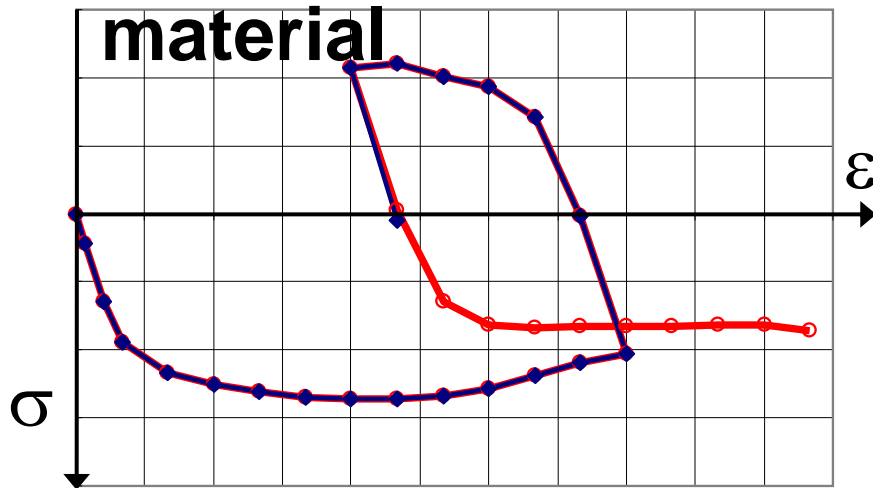

$$\Psi_p = \Psi_p(\mathbf{C}_\infty, \xi_p)$$

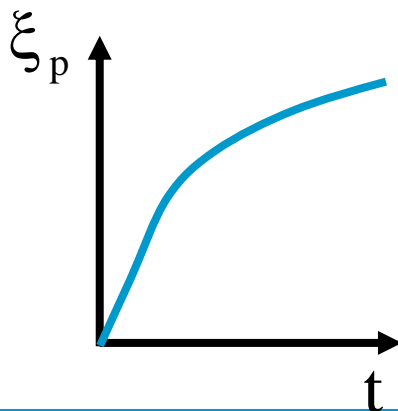

- In-elastic healing material**

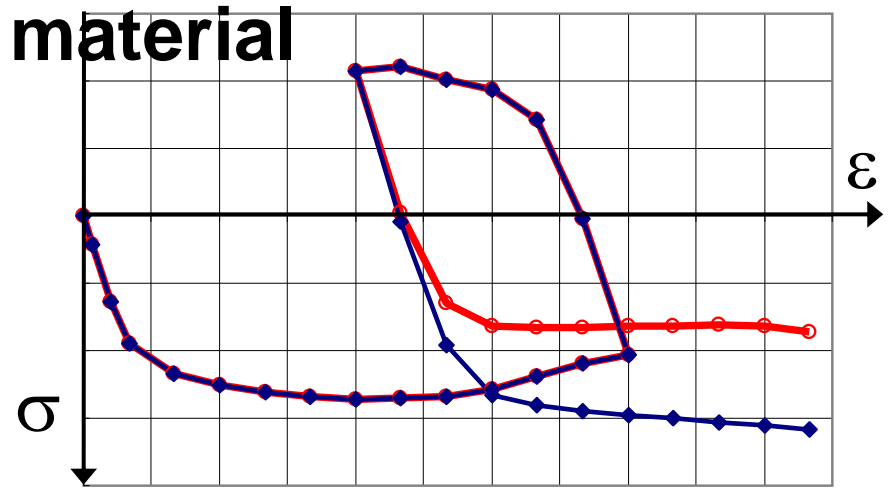

$$\Psi_{ph} = \Psi_{ph}(\mathbf{C}_\infty, \xi_p, \xi_h)$$

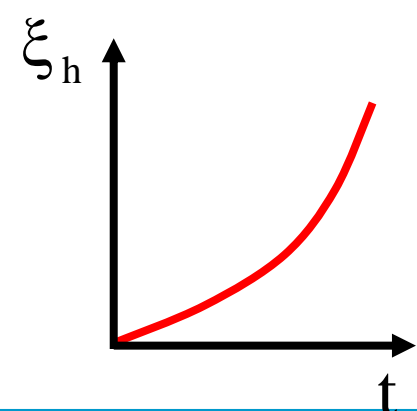
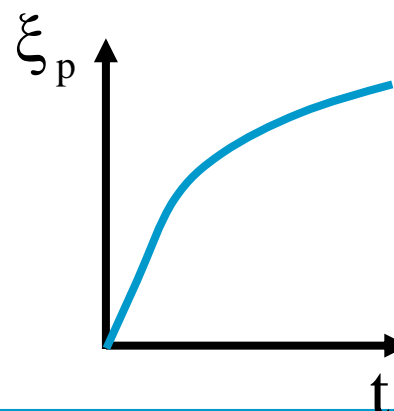

Constitutive Formulation

$$\Psi_p = \Psi_p(\mathbf{C}_\infty, \xi_p, \xi_h)$$

Dissipated energy :

$$2\mathbf{F}_\infty \frac{\partial \Psi_p}{\partial \mathbf{C}_\infty} \mathbf{F}_\infty^T \mathbf{F}_\infty^{-T} : \mathbf{F}_\infty \dot{l}_p - \frac{\partial \Psi_p}{\partial \xi_p} \dot{\xi}_p + \frac{\partial \Psi_p}{\partial \xi_h} \dot{\xi}_h \geq 0$$

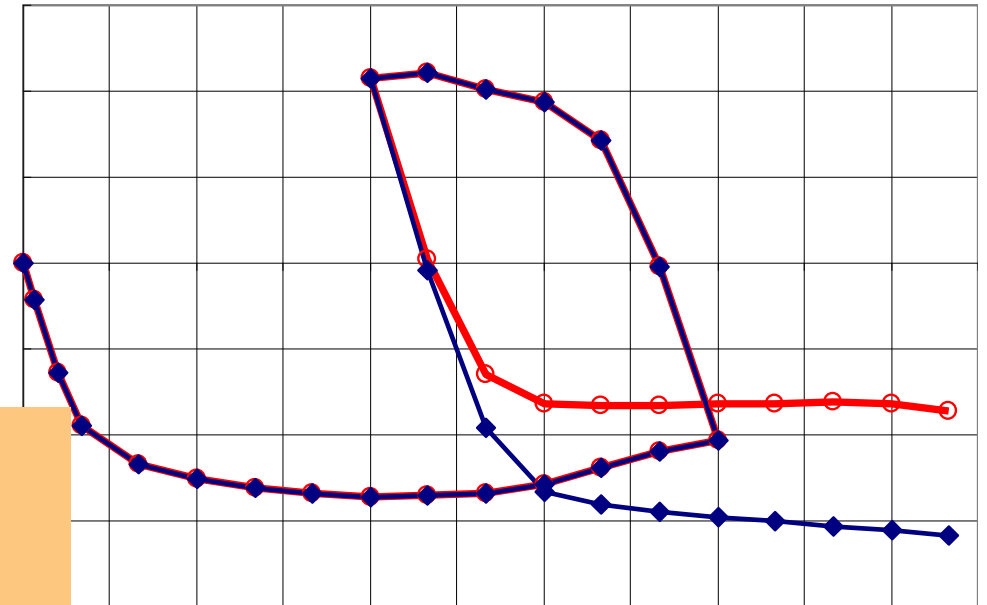

Constitutive Formulation

$$\Psi_p = \Psi_p(\mathbf{C}_\infty, \xi_p, \xi_h)$$

Dissipated energy :

$$2\mathbf{F}_\infty \frac{\partial \Psi_p}{\partial \mathbf{C}_\infty} \mathbf{F}_\infty^T \mathbf{F}_\infty^{-T} : \mathbf{F}_\infty \dot{l}_p - \frac{\partial \Psi_p}{\partial \xi_p} \dot{\xi}_p + \frac{\partial \Psi_p}{\partial \xi_h} \dot{\xi}_h \geq 0$$

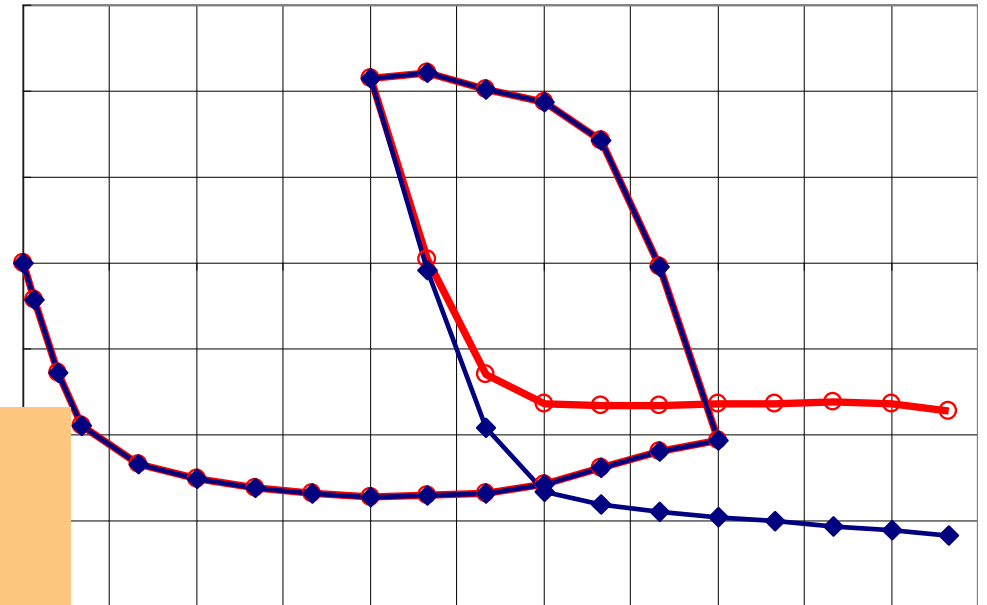

$$\xi_h = \xi_h(\phi_1, \phi_2, \dots)$$

$$\phi_1 = \phi_1(\dots, t, \dots)$$

Constitutive Formulation

$$\Psi_p = \Psi_p(\mathbf{C}_\infty, \xi_p, \xi_h)$$

Dissipated energy :

$$2\mathbf{F}_\infty \frac{\partial \Psi_p}{\partial \mathbf{C}_\infty} \mathbf{F}_\infty^T \mathbf{F}_\infty^{-T} : \mathbf{F}_\infty \dot{l}_p - \frac{\partial \Psi_p}{\partial \xi_p} \dot{\xi}_p + \frac{\partial \Psi_p}{\partial \xi_h} \dot{\xi}_h \geq 0$$

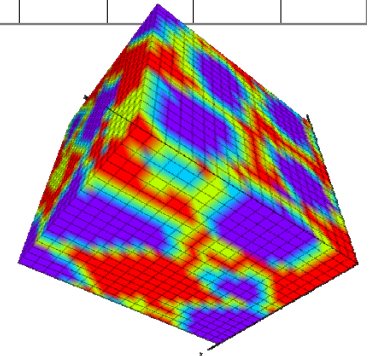
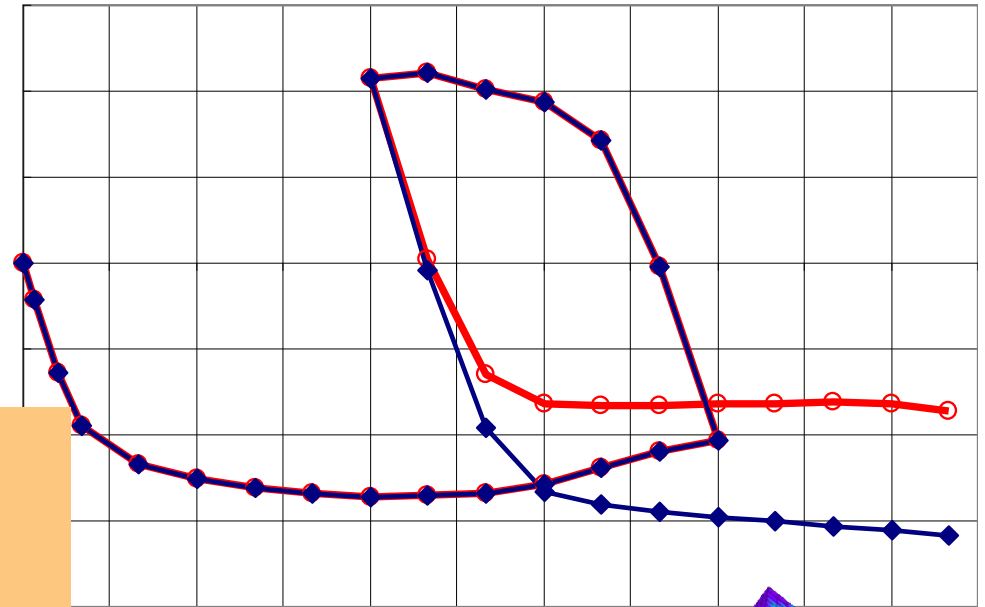

$$\xi_h = \xi_h(\phi_1, \phi_2, \dots)$$

Interfaces (thickness, distribution)

$$\phi_1 = \phi_1(\dots, t, \dots)$$

Constitutive Formulation

$$\Psi_p = \Psi_p(\mathbf{C}_\infty, \xi_p, \xi_h)$$

Dissipated energy :

$$2\mathbf{F}_\infty \frac{\partial \Psi_p}{\partial \mathbf{C}_\infty} \mathbf{F}_\infty^T \mathbf{F}_\infty^{-T} : \mathbf{F}_\infty \dot{\mathbf{l}}_p - \frac{\partial \Psi_p}{\partial \xi_p} \dot{\xi}_p + \frac{\partial \Psi_p}{\partial \xi_h} \dot{\xi}_h \geq 0$$

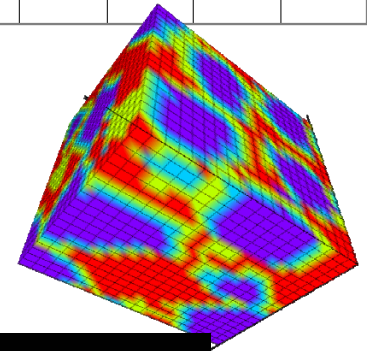
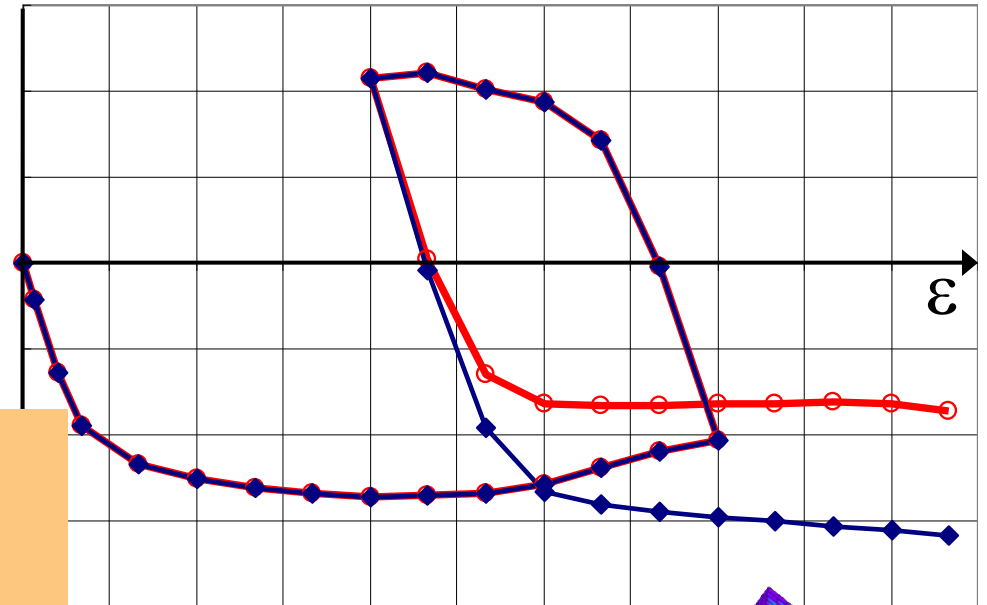

$$\xi_h = \xi_h(\phi_1, \phi_2, \dots)$$

$$\phi_1 = \phi_1(\dots, t, \dots)$$

Interfaces (thickness, distribution)

Rate of phase movement

Level of oxidation

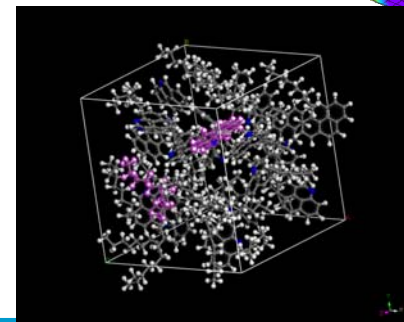

Constitutive Formulation

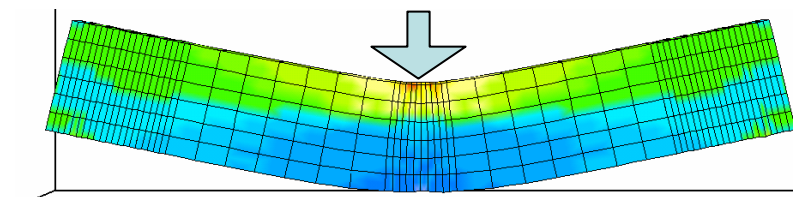
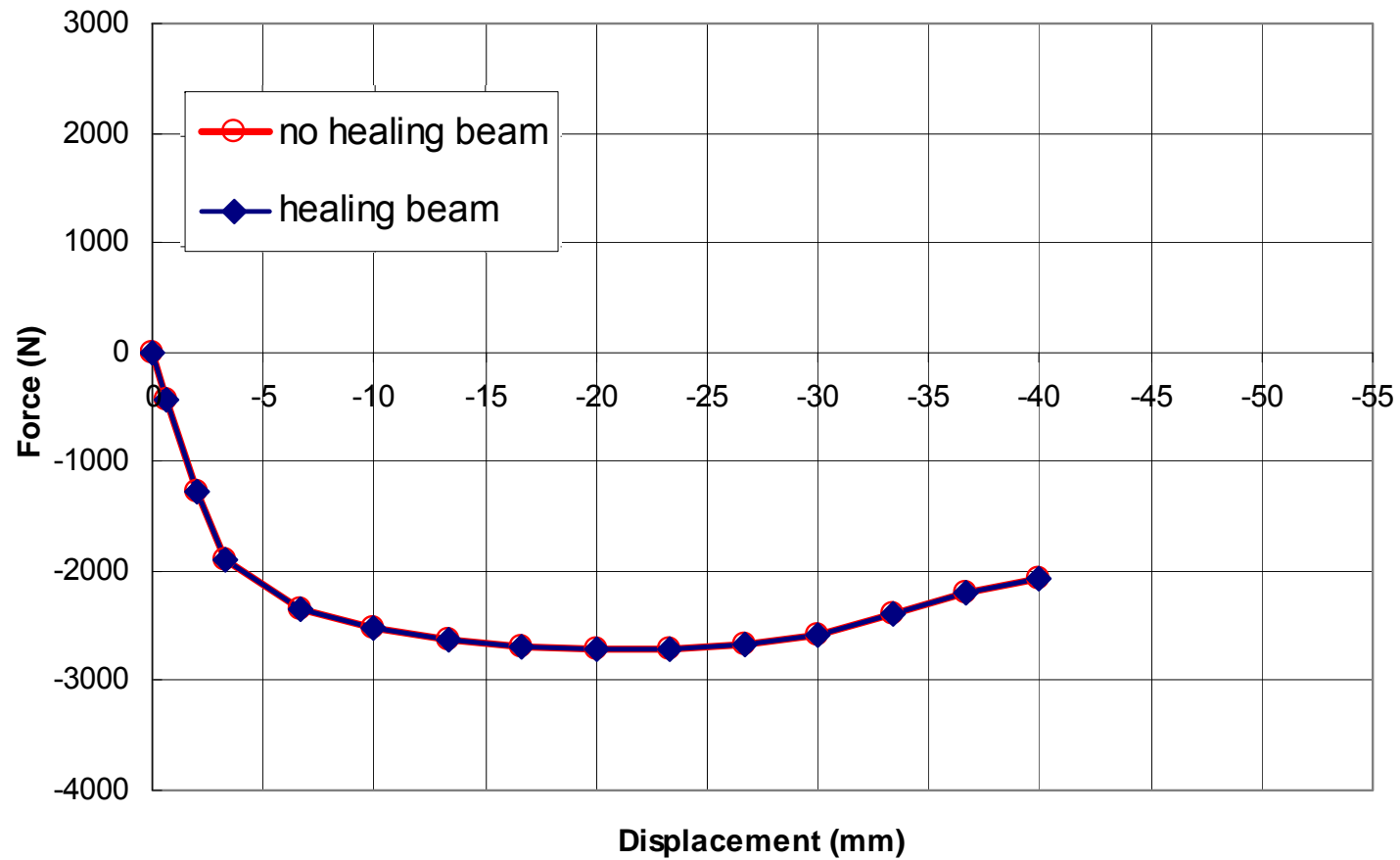

(Liu & Scarpas)

Constitutive Formulation

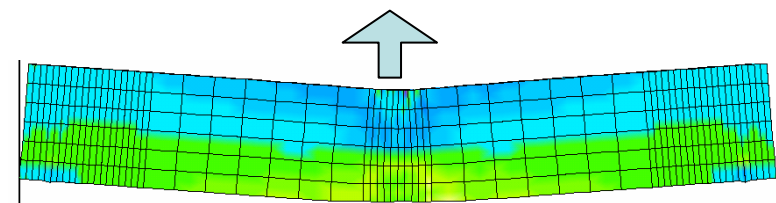
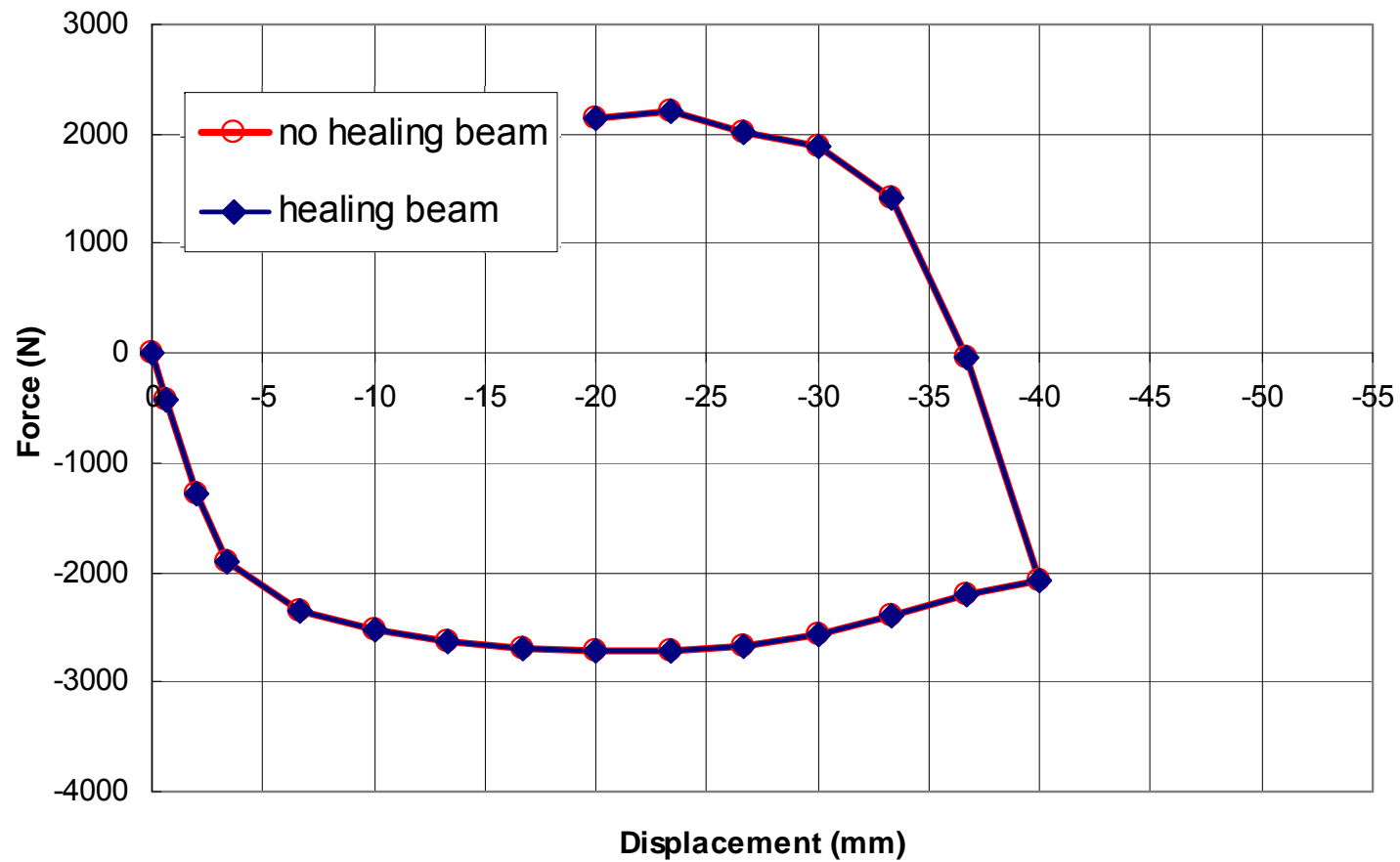

(Liu & Scarpas)

Constitutive Formulation

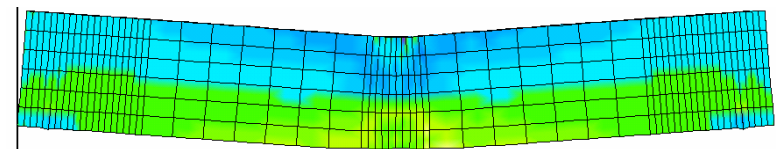
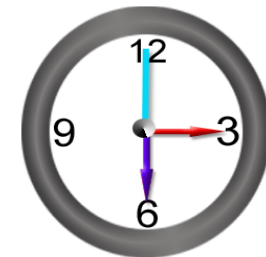
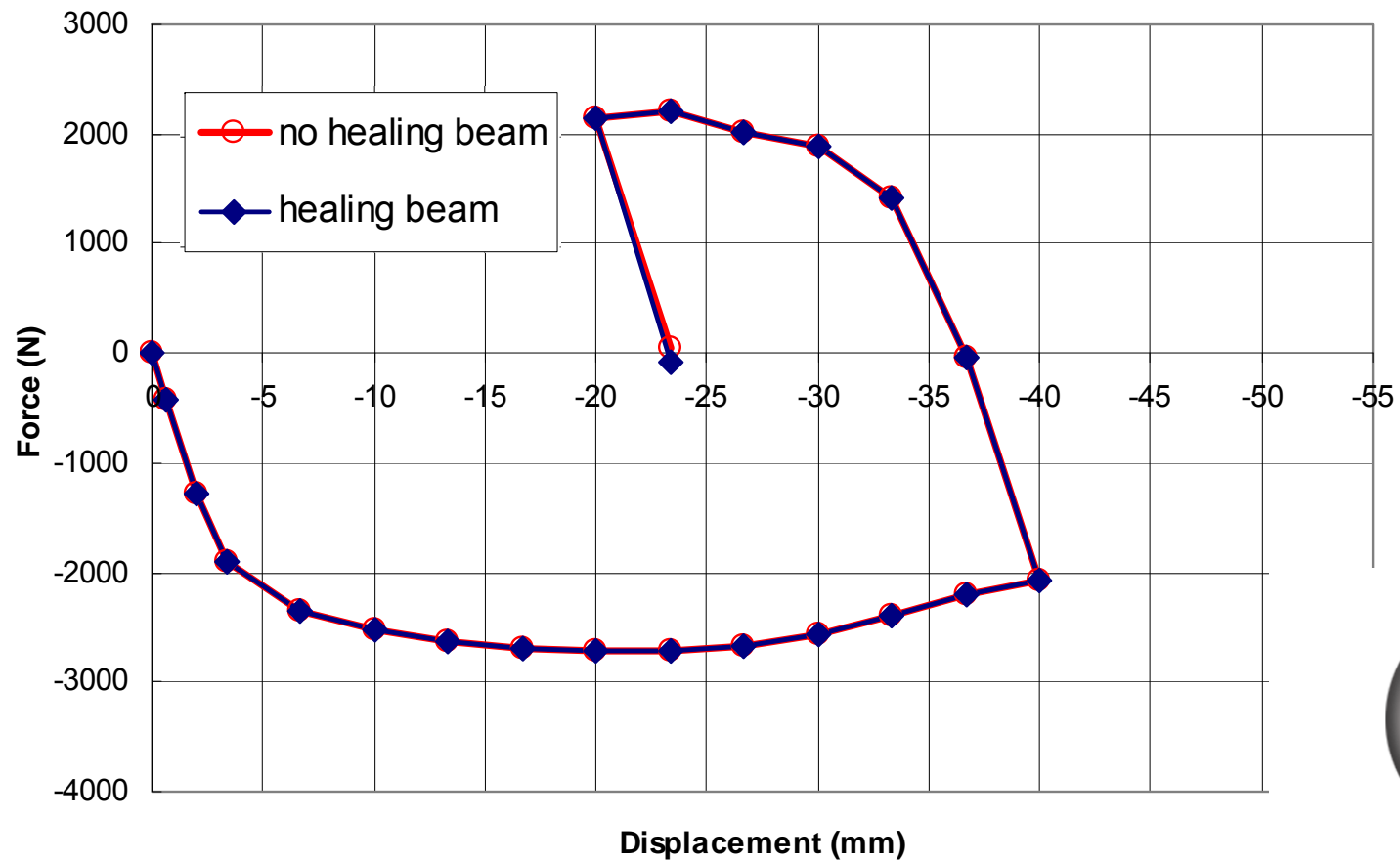

(Liu & Scarpas)

Constitutive Formulation

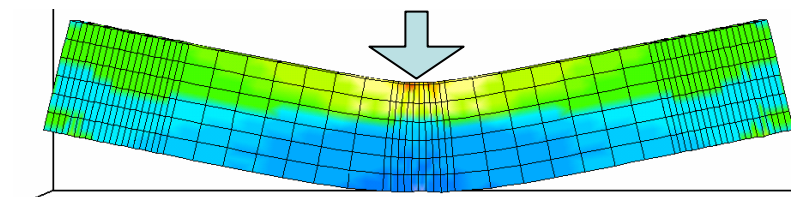
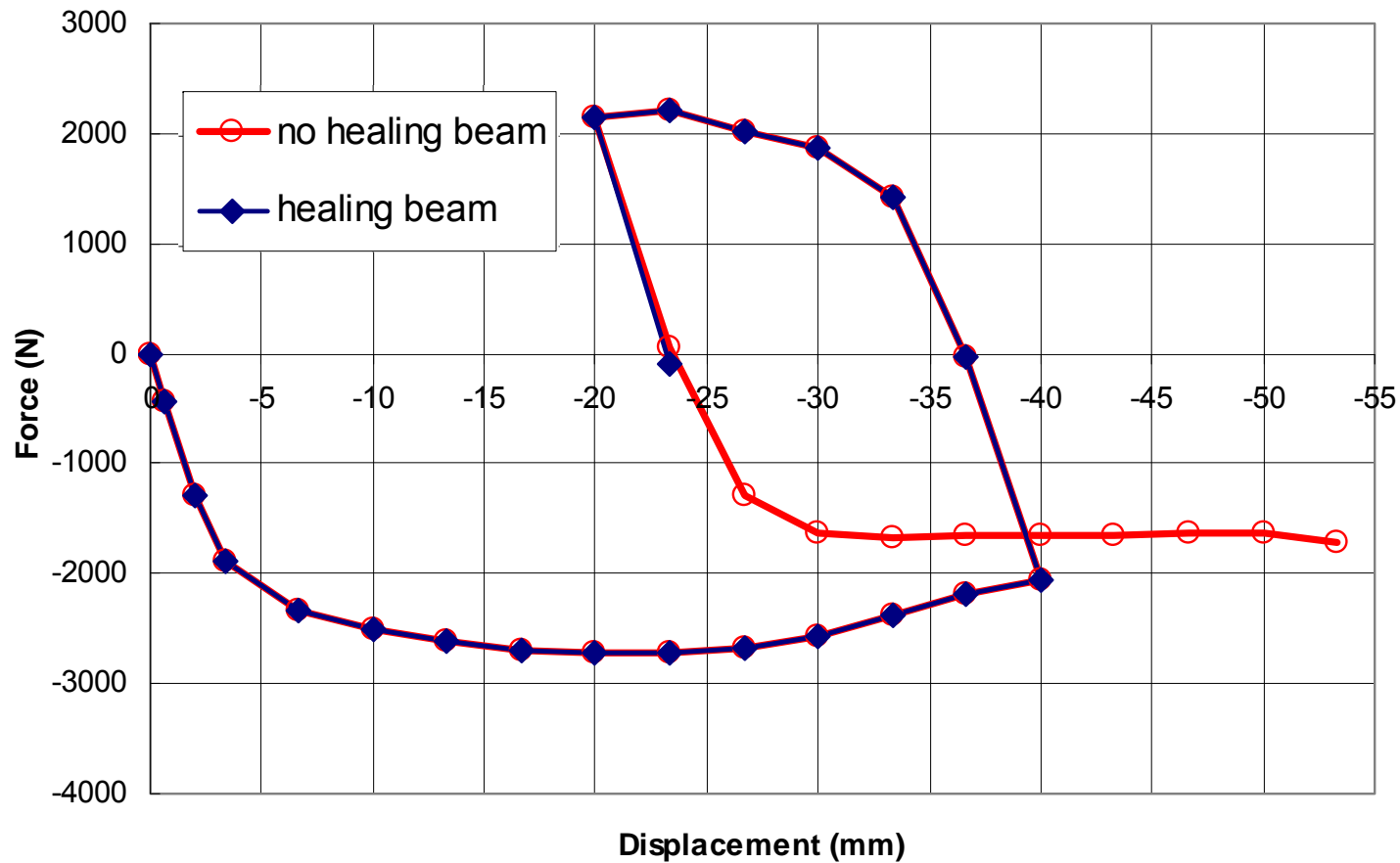

(Liu & Scarpas)

Constitutive Formulation

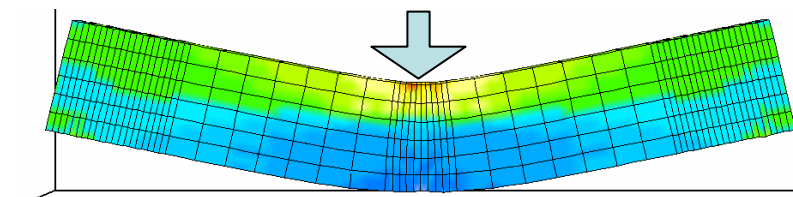
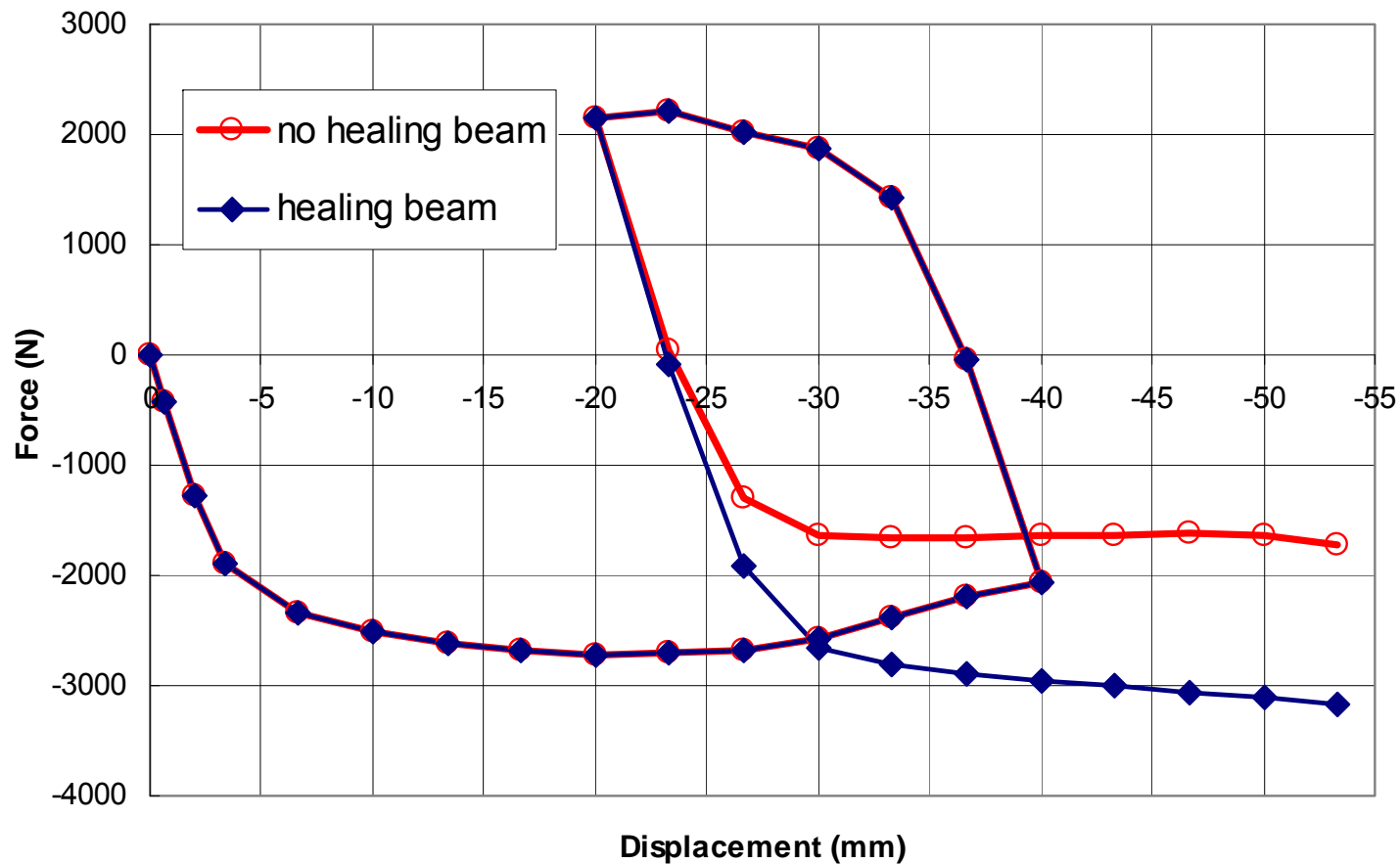

(Liu & Scarpas)

Wax induced Phase Separation !!!

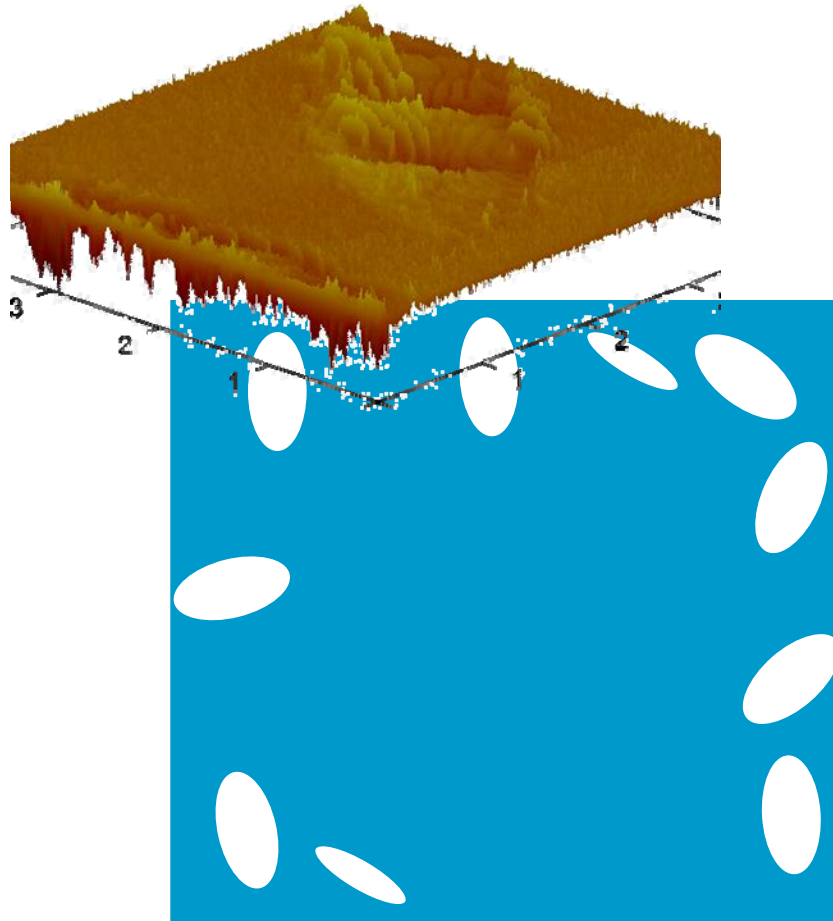

surface effect?



bulk?

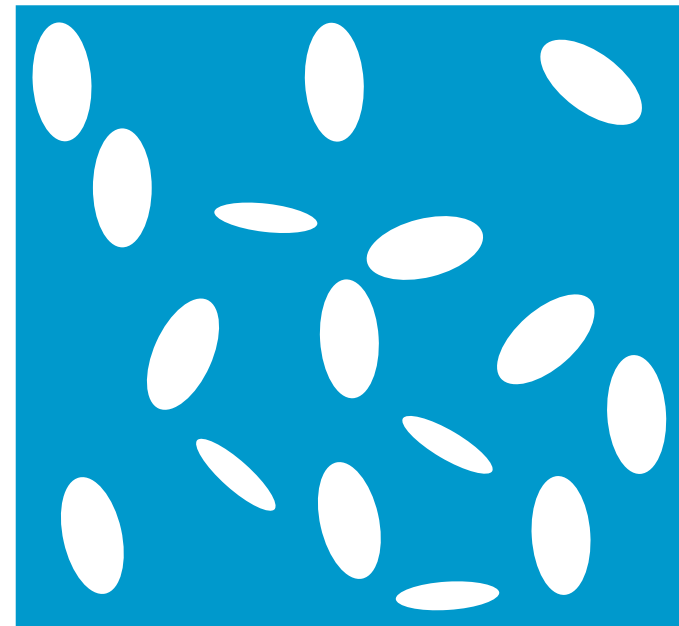

Wax induced Phase Separation !!!

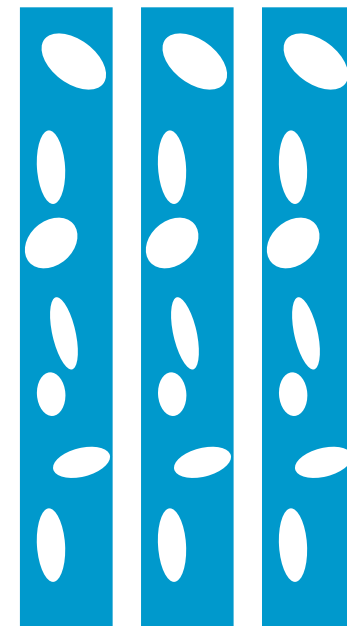
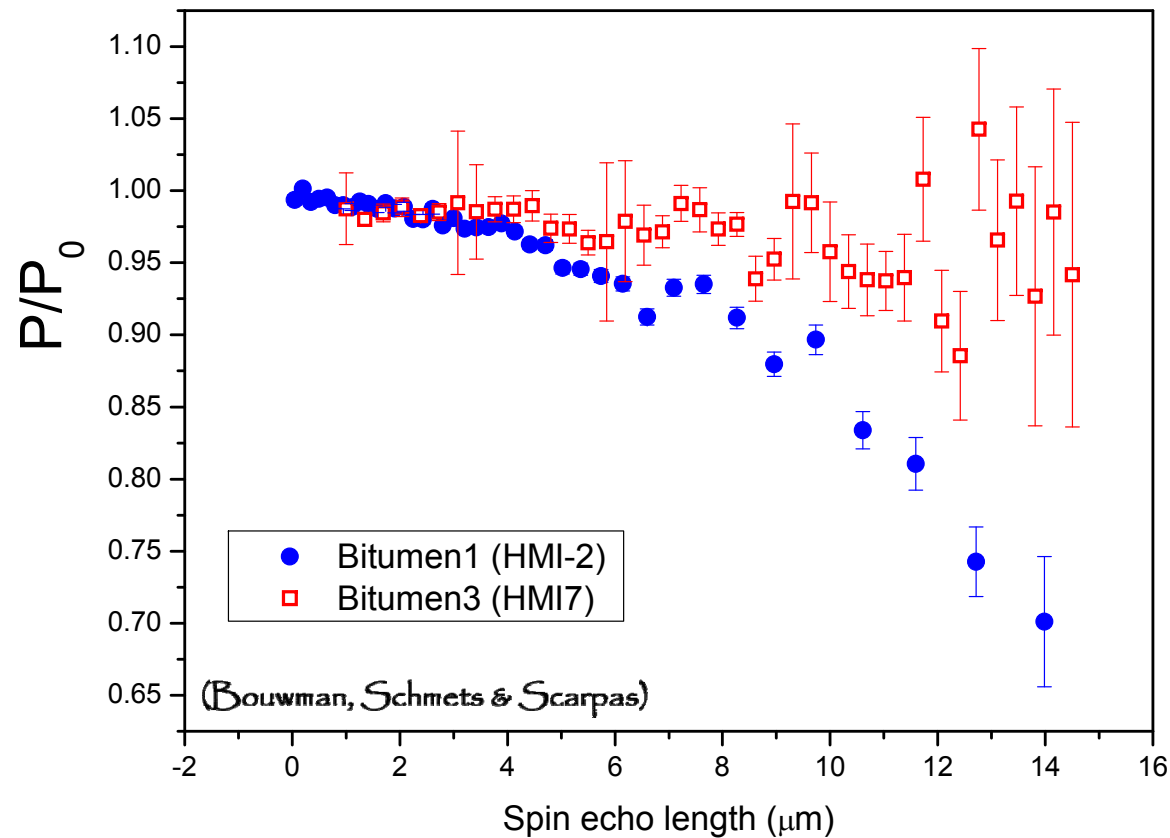

Spin echo small angle
neutron scattering
SESANS



Continued work on:

- multi-phase model (enabling the use of range of material parameters, such as solubility)
 - *interfacial kinetics*
- mechanical properties of:
 - wax (as a function of temperature, ...)
 - matrix (as a function of temperature, ...)
- upscaling procedure
- mobility/diffusivity/activation energy (linking to rest periods)
- linking the model to healing tests (?)
-



Thank you !!!

T. Scarpas

N. Kringos, T. Pauli, A. Schmets

Group of Mechanics of Infrastructure Materials

Section of Structural Mechanics

Faculty of Civil Engineering and Geosciences

TU Delft